

Advantages for the MicroLogix 1400 Controller

- Large memory (10 KB user program with 10 KB user data) to solve a variety of applications.
- True online editing allows tuning of program, including PID, without going offline.
- Support for MicroLogix 1400 controller online editing in RSLogix 500 Professional, Standard, and Starter software version 8.1 and later, as well as RSLogix Micro.
- Mode switch for Run/Remote/Program through LCD keypad operation.
- Time-based or event-triggered data logging capability stores controller data records with optional time stamp in a separate 128 Kbyte memory area for later analysis (for example, trending and I/O status during alarm condition data).
- Recipe storage (up to 64 KB that is deducted from Data Logging memory) that is accessible by your ladder program, enabling quick and easy batch changes of program data for timers, counters, and other data types.
- High performance expansion I/O options (up to seven 1762 I/O modules, in any combination).
- Twelve high-speed inputs (except 1766-L32AWA and 1766-L32AWAA controllers) that can be used individually as latching (pulse-catch) inputs, event interrupts, or alternately combined as three 100 kHz high-speed counters featuring 10 modes of operation.
- Two available built-in 0...10V DC analog outputs (for controllers with analog I/O options) with 12-bit resolution (not isolated).
- Three high-speed outputs that can be configured as 100 kHz pulse train output (PTO) or 40 kHz as pulse width modulated (PWM) outputs (only on 1766-L32BXB and 1766-L32BXBA controllers).
- Multiple input commons let you use the controller for either sinking or sourcing input devices, and multiple output commons provide individual isolation in multi-voltage output applications.
- One, 1 ms, selectable timed interrupt (STI).
- High-resolution, 1 ms timers.
- Communication Channel 0 provides isolated RS-232 or RS-485 electrical compatibility (selectable through the choice of communication cables).
- Through RS-232, we support all serial protocols.
- Through RS-485, we support direct interface to DH-485, DF1 half-duplex master/slave, ASCII, and Modbus RTU master/slave networks, DNP 3 slave using the 1763-NC interface (1761-NET-AIC interface is not required).
- Communication Channel 1 consists of an embedded RJ45 port that supports EtherNet/IP, Modbus TCP/IP and DNP3 over IP. This 10/100 Mbps port supports BOOTP and DHCP.
- Communication channel 2 provides a 9-pin, non-isolated RS-232 port supporting all serial protocols.
- Communication toggle selection that allows the controller's Channel 0 port to toggle between user-configured communication parameters and factory default settings for an easy way to switch from Modbus RTU or ASCII protocols (which do not support programming) to DF1 full-duplex (to upload/download, monitor, or edit your program). So a programming computer is able to connect to a controller with an unknown or incorrect communication-parameter settings for troubleshooting.
- Embedded real-time clock.
- Embedded web server with email functionality.

MicroLogix 1200 System Mounting Dimensions

For more than 2 modules: (number of modules - 1) x 40 mm (1.58 in.)

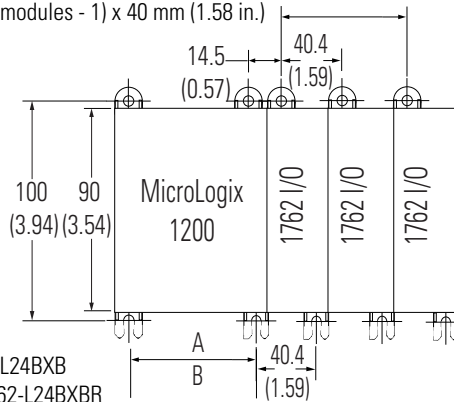

A = 95.86 mm (3.774 in.)
 1762-L24AWA, 1762-L24BWA, 1762-L24BXB
 1762-L24AWAR, 1762-L24BWAR, 1762-L24BXBR

B = 145.8 mm (5.739 in.)
 1762-L40AWA, 1762-L40BWA, 1762-L40BXB
 1762-L40AWAR, 1762-L40BWAR, 1762-L40BXBR

Important: All dimensions are in mm (inches). Hole spacing tolerance: ±0.4 mm (0.016 in.).

MicroLogix 1400 Controller

Dimensions are in millimeters (inches).

Controller Spacing = 50 mm (2 in.) on all sides for adequate ventilation. Refer to [page 27](#) for DIN rail mounting dimensions.

MicroLogix 1400 Controller Dimension Drawing

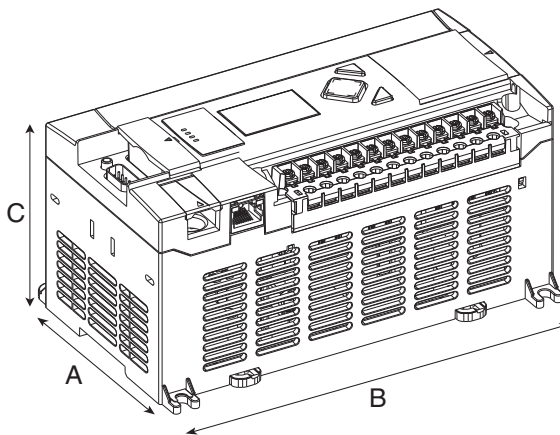

1766-L32BWA, 1766-L32AWA, 1766-L32BXB,
 1766-L32BWAA, 1766-L32AWAA, 1766-L32BXBA

Controller Dimensions

Dimension	Height
A	90 mm (3.5 in.)
B	180 mm (7.08 in.)
C	87 mm (3.43 in.)

1762 Expansion I/O Dimensions

1762 I/O Dimensions

Dimension	Expansion I/O Module
A	90 mm (3.5 in.)
B	40 mm (1.57 in.)
C	87 mm (3.43 in.)

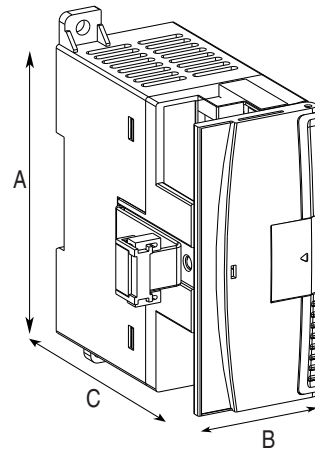

MicroLogix 1400 System Mounting Dimension

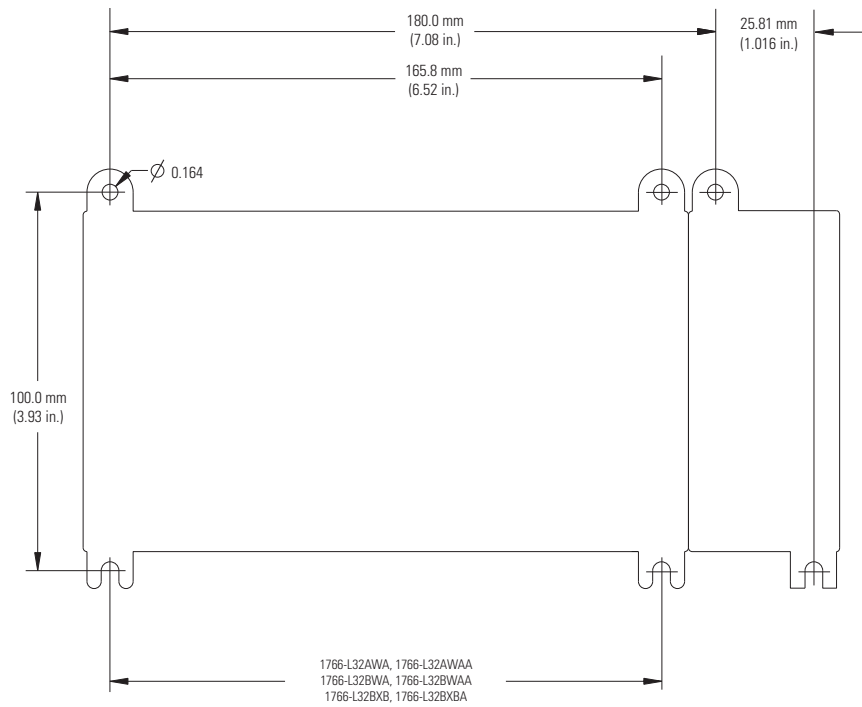

Select MicroLogix 1400 Controllers

MicroLogix 1400 Base Units

The base unit houses embedded inputs, outputs, power supply, and communication ports. The base unit also provides the interface to expansion I/O when required by an application.

Step 10 - Select:

- controller - review power and I/O configurations to select a controller catalog number; see power supply and I/O specification for more detailed information
- accessories - memory modules
- record your selection in the Selection Record (starts on [page 86](#))

MicroLogix 1400 Controller Catalog Number Detail

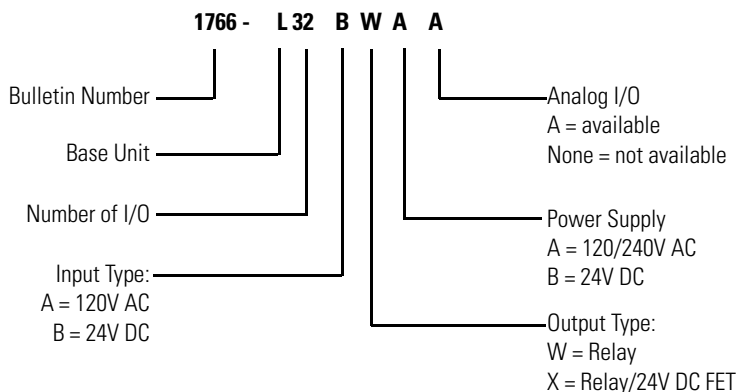

MicroLogix 1400 Controller Power and I/O Configuration

Cat. No.	Line Voltage	Number of Inputs	Number of Outputs	Embedded Analog I/O
1766-L32BWA	120/240V AC	(12) Fast 24V DC (8) Normal 24V DC	(12) Relay	---
1766-L32AWA	120/240V AC	(20) 120V AC	(12) Relay	---
1766-L32BXB	24V DC	(12) Fast 24V DC (8) Normal 24V DC	(6) Relay (3) Fast 24V DC (3) Normal 24V DC	---
1766-L32BWAA	120/240V AC	(12) Fast 24V DC (8) Normal 24V DC	(12) Relay	(4) Voltage Inputs (2) Voltage Outputs
1766-L32AWAA	120/240V AC	(20) 120V AC	(12) Relay	(4) Voltage Inputs (2) Voltage Outputs
1766-L32BXBA	24V DC	(12) Fast 24V DC (8) Normal 24V DC	(6) Relay (3) Fast 24V DC (3) Normal 24V DC	(4) Voltage Inputs (2) Voltage Outputs

MicroLogix 1400 Controller Power Supply Specifications

Attribute	1766-L32AWA, 1766-L32AWAA	1766-L32BWA, 1766-L32BWAA	1766-L32BXB, 1766-L32BXBA
Power Supply Voltage	100...240V AC (-15%, 10%) at 47...63 Hz		24V DC (-15%, 10%) Class 2 SELV

MicroLogix 1400 Controller Power Supply Specifications

Attribute	1766-L32AWA, 1766-L32AWAA	1766-L32BWA, 1766-L32BWAA	1766-L32BXB, 1766-L32BXBA
Power Consumption	100 VA	120 VA	7.5...53 W
Power Supply Inrush Current, max	120V AC: 25 A for 8 ms 240V AC: 40 A for 4 ms		24V DC: 15 A for 20 ms
24V DC Sensor Power	---	24V DC at 250 mA, 400µF capacitance, max	---

MicroLogix 1400 Controller DC Input Power Requirements for 1766-L32BXB and 1766-L32BXBA Units

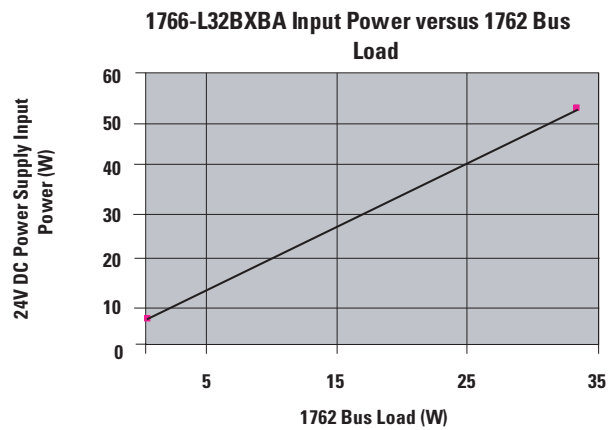

MicroLogix 1400 Controller Digital Input Specifications

Attribute	1766-L32AWA, 1766-L32AWAA	1766-L32BWA, 1766-L32BWAA, 1766-L32BXB, 1766-L32BXBA	
		Inputs 0...11 (12 high-speed DC inputs)	Inputs 12 and above (8 standard DC inputs)
On-state Voltage Range	79...132V AC	4.5...24V DC 4.5...26.4V DC at 60 °C (140 °F) 4.5...30V DC at 30 °C (86 °F)	10...24V DC 10...26.4V DC at 60 °C (140 °F) 10...30V DC at 30 °C (86 °F)
Off-state Voltage Range	0...20V AC	0...1.5V DC	0...5V DC
Operating Frequency	47...63 Hz	0 Hz...100 kHz	0 Hz...1 kHz (scan time dependent)
On-state Current min nom max	5.0 mA @ 79 V AC 12 mA @ 120 V AC 16.0 mA @ 132 V AC	7.1 mA @ 4.5V DC 9.9 mA @ 24V DC 10.5 mA @ 30V DC	3.2 mA @ 10V DC 5.3 mA @ 24V DC 5.5 mA @ 30V DC
Off-state Leakage Current, max	2.5 mA, max	0.2 mA, max	1.5 mA, max
Impedance, nom	12 k Ω at 50 Hz 10 k Ω at 60 Hz	2.4 k Ω	4.5 k Ω
Inrush Current, max	250 mA		

MicroLogix 1400 Controller Analog Input Specifications

Attribute	Value
Voltage Input Range	0...10.0V DC - 1 LSB
Type of Data	12-bit unsigned integer
Input Coding (0...10V DC)	0...4095
Voltage Impedance	>199 k Ω
Input Resolution	12 bit
Non-linearity (in percent full scale)	\pm 0.5% of full scale
Overall Accuracy	\pm 1.0% of full scale
Update Time	100/20/16.67/4 ms (selectable)
Voltage Input Overvoltage Protection	10.5 V DC
Field Wiring to Logic Isolation	Non-isolated with internal logic

MicroLogix 1400 Controller Analog Output Specifications

Attribute	Value
Voltage Output Range	0...10.0V DC - 1 LSB
Type of Data	12-bit unsigned integer
Step Response	2.5 ms @ 95%
Output Coding (0...10V DC)	0...4095
Load Range Voltage Output	>1 k Ω
Output Resolution	12 bit
Analog Output Setting Time	3 ms, max
Overall Accuracy	\pm 1.0% of full scale
Electrical Isolation	Non-isolated with internal logic
Cable Length	30 m (98 ft) shielded cable

Specifications for MicroLogix 1400 Controller Outputs in Hazardous locations (Class 1, Division 2, Groups A, B, C, D)

Relay and FET Outputs

Attribute		1766-L32AWA, 1766-L32AWAA, 1766-L32BWA, 1766-L32BWAA	1766-L32BXB, 1766-L32BXBA
Controlled Load, max		1440 VA	1080 VA
Continuous Current, max			
Current per Channel and Group Common		2.5 A per channel 8 A max channel 8...11 common	2.5 A per channel
Current per Controller	@ 150V, max	28 A or total of per-point loads, whichever is less	
	@ 240V, max	20 A or total of per-point loads, whichever is less	

Relay Outputs

Attribute	Value
Turn On Time/Turn Off Time	10 ms, max ⁽¹⁾
Load Current	10 mA

(1) Scan time dependent.

Relay Contact Rating

Voltage, max	Amperes		Amperes Continuous	Voltamperes	
	Make	Break		Make	Break
240V AC	7.5 A	0.75 A	2.5 A	1800 VA	180 VA
120V AC	15 A	1.5 A			
250V DC	0.11 A		1.0 A	28 VA	
125V DC	0.22 A		1.0 A	28 VA	

1766-L32BXB, 1766-L32BXBA FET Outputs

Attribute	General Operation	High-speed Operation (outputs 2, 3, and 4 only) ⁽¹⁾
Power Supply Voltage (Class 2)	24V DC (-15%, +10%)	
On-state Voltage Drop at maximum load current at maximum surge current	1V DC 2.5V DC	Not Applicable Not Applicable
Current Rating per Point maximum load minimum load maximum leakage	See chart 1.0 mA 1.0 mA	100 mA 20 mA 1.0 mA

Master List of Catalog Numbers

Cat. No.	Description	Quantity Selected
1762-L40BWA	MicroLogix 1200 40-Point AC Controller	
1762-L40BWAR	MicroLogix 1200 40-Point AC Controller with Programming/HMI Port	
1762-L40BXB	MicroLogix 1200 40-Point DC Controller	
1762-L40BXHR	MicroLogix 1200 40-Point DC Controller with Programming/HMI Port	
1762-MM1	MicroLogix 1200 Memory Module	
1762-MM1RTC	MicroLogix 1200 Memory Module with Real-Time Clock	
1762-RTC	MicroLogix 1200 Real-Time Clock Module	
MicroLogix 1100/1200/1400 I/O		
1762-IA8	8-Point 120V AC Input Module	
1762-IF2OF2	Combination 2-Channel Input 2-Channel Output Voltage/Current Analog Module	
1762-IF4	4-Channel Voltage/Current Analog Input Module	
1762-IQ16	16-Point Sink/Source 24V DC Input Module	
1762-IQ8	8-Point Sink/Source 24V DC Input Module	
1762-IQ8OW6	8 Point Sink/Source 24V DC Input/6-Point AC/DC Relay Output Combination Module	
1762-IR4	4-Channel RTD/Resistance Input Module	
1762-IT4	4-Channel Thermocouple/mV Input Module	
1762-OA8	8-Point 120/240V AC Triac Output Module	
1762-OB16	16-Point Sourcing 24V DC Output Module	
1762-OB8	8-Point Sourcing 24V DC Output Module	
1762-OF4	4-Channel Voltage/Current Analog Output Module	
1762-OW16	16-Point AC/DC Relay Output Module	
1762-OW8	8-Point AC/DC Relay Output Module	
1762-OX6I	6-Point Isolated AC/DC Relay Output Module	
1762-OV32T	Solid State 24V DC Sink Output Module	
1762-OB32T	Solid State 24V DC Source Output Module	
1762-IQ32T	DC Input Module	
MicroLogix 1400 Controllers and Accessories		
1766-L32BWA	MicroLogix 1400 32-point AC controller	
1766-L32AWA	MicroLogix 1400 32-point AC controller	
1766-L32BXB	MicroLogix 1400 32-point DC controller	
1766-L32BWAA	MicroLogix 1400 32-point AC controller with Analog	
1766-L32AWAA	MicroLogix 1400 32-point AC controller with Analog	
1766-L32BXBA	MicroLogix 1400 32-point DC controller with Analog	
1766-MM1	MicroLogix 1400 Memory Module	
MicroLogix 1500 Controllers and Accessories		
1764-24AWA	MicroLogix 1500 24-Point AC Base Unit	
1764-24BWA	MicroLogix 1500 24-Point AC Base Unit	
1764-28BXB	MicroLogix 1500 28-Point DC Base Unit	
1764-DAT	MicroLogix Data Access Tool	
1764-LRP	MicroLogix 1500 Processor Unit with RS-232 Port	
1764-LSP	MicroLogix 1500 Processor Unit	
1764-MM1	MicroLogix 1500 8 KB Memory Module	
1764-MM1RTC	MicroLogix 1500 8 KB Memory Module with Real-Time Clock	
1764-MM2	MicroLogix 1500 16 KB Memory Module	