

Ultra3000 Digital Servo Drives



The Ultra3000, Ultra3000i, Ultra3000-SE, Ultra3000-DN, and Ultra3000X-DN drives make up a family of flexible, high-performance digital servo drives for a variety of motion control applications and architectures. The wide range of power platforms, connectivity options and functions makes the Ultra3000 digital servo drive family an attractive solution for a variety of machine control architectures including Logix, SLC, and third-party machine and motion control systems. In addition, the Ultra3000i indexing, Ultra3000-SE, Ultra3000-DN, Ultra3000X-DN drives are positioning drives designed for applications requiring either simple or complex motion profiles.

Only the 2098-DSD-xxx-SE and 2098-DSD-HVxxx-SE (SERCOS interface) drives are part of the Kinetix Integrated Motion solution.

Topic	Page
Ultra3000 Servo Drive Communication Interface	361
Ultra3000 Digital Servo Drive Components	362
Ultra3000 Digital Servo Drive Specifications	364
Ultra3000 Digital Servo Drive Dimensions	371
Ultra3000 Connector, Indicator, and Switch Locations	374
Ultra3000 Digital Servo Drive Catalog Numbers	377

Ultra3000 Servo Drive Communication Interface

Drive Type	Drive Cat. No.	Command Interface
SERCOS interface drive	2098-DSD-xxx-SE and 2098-DSD-HVxxx-SE	Fiber-optic SERCOS ring
Analog drive	2098-DSD-xxx and 2098-DSD-HVxxx	Analog command interface
Digital drive with DeviceNet interface	2098-DSD-xxx-DN and 2098-DSD-HVxxx-DN	DeviceNet communication interface
Indexing drive	2098-DSD-xxxX and 2098-DSD-HVxxxX	Standalone control
Indexing DeviceNet interface drives	2098-DSD-xxxX-DN and 2098-DSD-HVxxxX-DN	

Ultra3000 Digital Servo Drive Components

Ultra3000 digital servo drive systems consist of these required components:

- One Ultra3000 digital servo drive
- One rotary servo motor or linear motor/actuator (MP-Series, TL-Series, LDC-Series, or LDL-Series)
- One motor power and feedback cable
- Two SERCOS fiber-optic cables for Ultra3000-SE drives

Ultra3000 systems may also include any of these optional components:

- Bulletin 2090 external active or passive shunt module
- Bulletin 2090 Resistive Brake Module (RBM)

Typical Configuration - Ultra3000-SE (SERCOS) Digital Servo Drive System

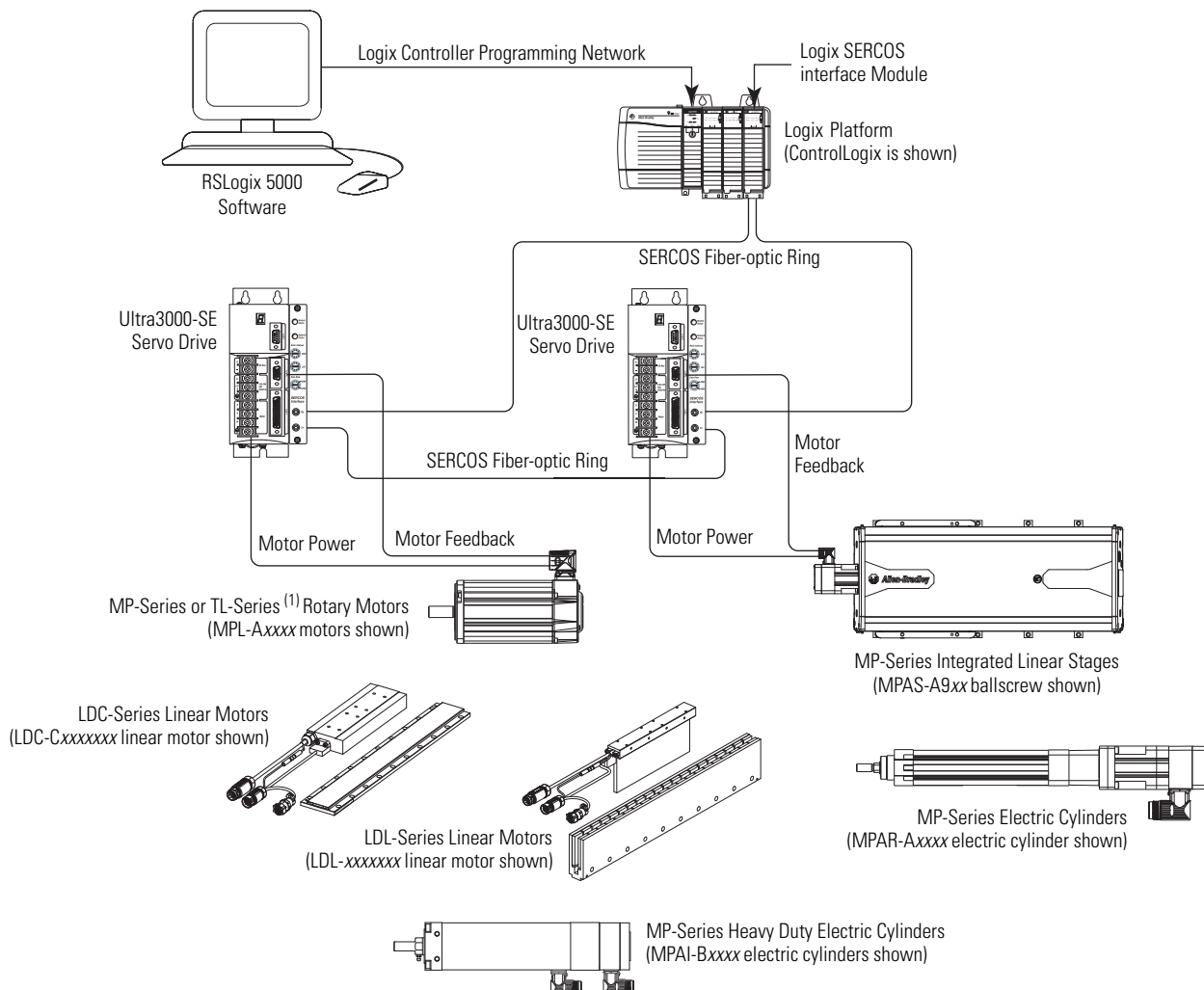

(1) Ultra3000 drives are compatible with only TL-Series (Bulletin TLY-Axxxx-H) motors with incremental encoders.

Typical Configuration - Ultra3000 Digital Servo Drive System

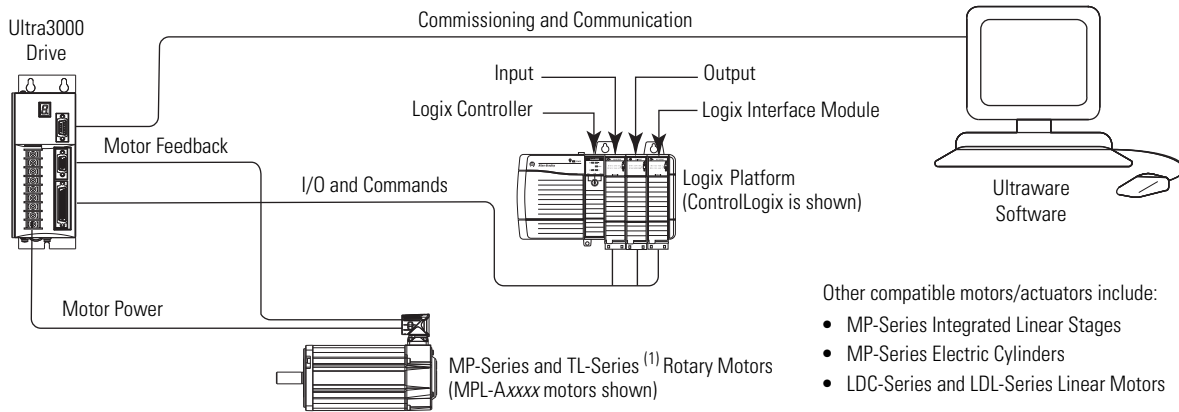

(1) Ultra3000 drives are compatible with only TL-Series (Bulletin TLY-Axxxx-H) motors with incremental encoders.

Typical Configuration - Ultra3000-DN (DeviceNet) Digital Servo Drive System

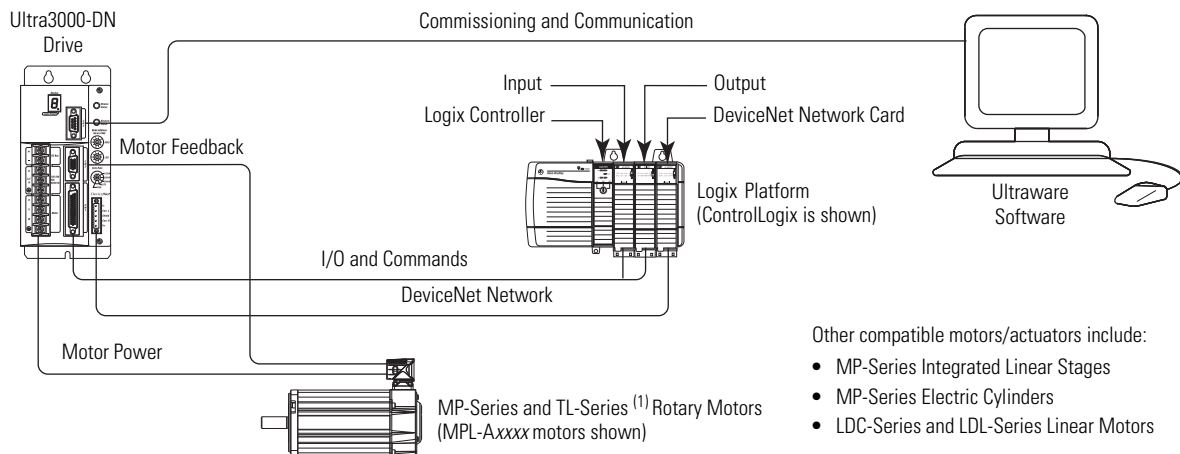

(1) Ultra3000 drives are compatible with only TL-Series (Bulletin TLY-Axxxx-H) motors with incremental encoders.

Ultra3000 Digital Servo Drive Specifications

This section contains general power, physical/environmental, power dissipation, controller, I/O, operating modes command sources, serial communication, network communication, feedback, and connector specifications for the Ultra3000 digital servo drives.

Specifications apply to these Ultra3000 drive models:

- SE indicates the 2098-DSD-xxx-SE SERCOS interface drive
- DN indicates the 2098-DSD-xxx-DN DeviceNet interface drive
- X indicates the 2098-DSD-xxxX indexing drive
- X-DN indicates the 2098-DSD-xxxX-DN indexing DeviceNet interface drive

Power Specifications

2098-DSD-005x-xx, 2098-DSD-010x-xx, and 2098-DSD-020x-xx Ultra3000 (230V) Drives

Attribute	2098-DSD-005	2098-DSD-010	2098-DSD-020
AC input voltage ⁽¹⁾	100...240V rms Single-phase		
AC input frequency	47...63 Hz		
AC input current ⁽²⁾⁽³⁾ Nom (rms) 230V AC (0-pk) max inrush ⁽⁴⁾	5 A 100 A - Series A or B 20 A - Series C	9 A 100 A - Series A or B 20 A - Series C	18 A 100 A - Series A or B 20 A - Series C
Continuous output current (rms)	1.8 A	3.5 A	7.1 A
Continuous output current (0-pk)	2.5 A	5.0 A	10 A
Peak output current (rms)	5.3 A	10.6 A	21.2 A
Peak output current (0-pk)	7.5 A	15 A	30 A
Bus capacitance	1410 μ F	1880 μ F	1880 μ F
Internal shunt resistance	N/A	N/A	N/A
Shunt on	N/A	N/A	N/A
Shunt off	N/A	N/A	N/A
Bus overvoltage	400V DC	400V DC	400V DC
Energy absorption capability 115V AC input 230V AC input	93 J 38 J	125 J 51 J	
Continuous power output 115V AC input 230V AC input	0.25 kW 0.5 kW	0.5 kW 1.0 kW	1.0 kW 2.0 kW

(1) Specification is for nominal voltage. The absolute limits are $\pm 10\%$, or 88...265V rms.

(2) The 2098-DSD-005x-xx, 2098-DSD-010x-xx, and 2098-DSD-020x-xx (230V) drives are limited to:

Series A or B - one contactor cycle every two minutes.

Series C - one contactor cycle every 10 s for up to two minutes, not to exceed 12 cycles in five minutes.

(3) Power initialization requires a short period of inrush current. Dual element time delay (slow blow) fuses are recommended (refer to Fuse Specifications on [page 367](#)).

(4) In-rush current limiting circuitry is enabled within 3 s after removal of AC line power.

2098-DSD-030x-xx, 2098-DSD-075x-xx, and 2098-DSD-150x-xx Ultra3000 (230V) Drives

Attribute	2098-DSD-030	2098-DSD-075	2098-DSD-150
AC input voltage ⁽¹⁾	100...240V rms Single-phase	100...240V rms Three-phase	
AC input frequency	47...63 Hz		
Main AC input current ⁽²⁾⁽³⁾			
Nom (rms)	28 A	30 A	46 A
230V AC (0-pk) max inrush	50 A	50 A	68 A
Auxiliary AC input current			
115V AC (rms) nom	1.0 A	1.0 A	1.0 A
230V AC (rms) nom	0.5 A	0.5 A	0.5 A
115V AC (0-pk) max inrush ⁽⁴⁾	47 A	47 A	47 A
230V AC (0-pk) max inrush ⁽⁴⁾	95 A	95 A	95 A
Continuous output current (rms)	10.6 A	24.7 A	45.9 A
Continuous output current (0-pk)	15 A	35 A	65 A
Peak output current (rms)	21.2 A	53 A	106 A
Peak output current (0-pk)	30 A	75 A	150 A
Bus capacitance	2820 μ F	4290 μ F	7520 μ F
Internal shunt resistance	35 Ω	16.5 Ω	9.1 Ω
Shunt on	420V DC	420V DC	420V DC
Shunt off	402V DC	402V DC	402V DC
Bus overvoltage	452V DC	452V DC	452V DC
Internal shunt			
Continuous power	50 W	50 W	180 W
Peak power	4.5 kW	10 kW	18 kW
External shunt			
Resistance	30 Ω (-0/+5%)	16.5 Ω (-0/+5%)	9 Ω (-0/+5%)
Continuous power	2.4 kW	4 kW	8 kW
Peak power	6 kW	10 kW	19 kW
Energy absorption capability			
115V AC input	251 J	381 J	669 J
230V AC input	139 J	211 J	370 J
Continuous power output			
115V AC input	1.5 kW	N/A	N/A
230V AC input	3 kW	7.5 kW	15 kW

(1) Specification is for nominal voltage. The absolute limits are $\pm 10\%$, or 88...265V rms.

(2) The 2098-DSD-030x-xx, 2098-DSD-075x-xx, and 2098-DSD-150x-xx (230V) drives are limited to one contactor cycles per two minutes.

(3) Power initialization requires a short period of inrush current. Dual element time delay (slow blow) fuses are recommended (refer to Fuse Specifications on [page 367](#)).

(4) 400 μ s half wave sine.

Ultra3000 460V Drives

Attribute	2098-DSD-HV030	2098-DSD-HV050	2098-DSD-HV100	2098-DSD-HV150	2098-DSD-HV220
AC input voltage ⁽¹⁾⁽²⁾	230...480V rms Three-phase				
AC input Frequency	47...63 Hz				
Main AC input current ⁽³⁾⁽⁴⁾ 460V AC (rms) nom 460V AC (rms) max inrush	4 A 6 A	7 A 6 A	14 A 6 A	20 A 6 A	28 A 6 A
Auxiliary AC input current 230V AC (rms) nom 360V AC (rms) nom 480V AC (rms) nom 230V AC (0-pk) max inrush ⁽⁵⁾ 480V AC (0-pk) max inrush ⁽⁵⁾	0.55 A 0.35 A 0.25 A 47 A 68 A				
Continuous output current (rms)	5.0 A	7.8 A	16.3 A	24.0 A	33.2 A
Continuous output current (0-pk)	7.0 A	11 A	23 A	34 A	47 A
Peak output current (rms)	9.9 A	15.6 A	32.5 A	48.1 A	66.5 A
Peak output current (0-pk)	14 A	22 A	46 A	68 A	94 A
Bus capacitance	470 µF		705 µF	940 µF	1880 µF
Internal shunt resistance	120 Ω		40 Ω	25 Ω	20 Ω
Shunt on 230V AC input 480V AC input	400V DC 800V DC				
Shunt off 230V AC input 480V AC input	375V DC 750V DC				
Bus overvoltage 230V AC input 480V AC input	410V DC 810V DC				
Internal shunt Continuous power Peak power	100 W 5.3 kW		200 W 16 kW	200 W 25.6 kW	400 W 32 kW
External shunt Resistance (-0/+5%) Continuous power Peak power	120 Ω 3 kW 5.3 kW		40 Ω 10 kW 16 kW	25 Ω 15 kW 25.6 kW	20 Ω 22 kW 32 kW
Energy absorption capability 230V AC input with 230V motor 230V AC input with 460V motor 480V AC input	15 J 129 J 55 J		22 J 194 J 82 J	29 J 259 J 109 J	59 J 517 J 219 J
Continuous power output 230V AC input 480V AC input	1.5 kW 3.0 kW	2.5 kW 5.0 kW	5.0 kW 10 kW	7.5 kW 15 kW	11 kW 22 kW

- (1) Specification is for nominal voltage. The absolute limits are ±10%, or 207...264V rms and 324...528V rms.
- (2) The 2098-DSD-HVxxx-xx drives can be powered with 230V rms and used with motors designed for 230V operation. In such cases, the voltage levels used for shunting and DC bus overvoltage limits are adjusted to be compatible with the voltage limit of the motor.
The 2098-DSD-HVxxx-xx drives can be powered with 480V rms and used with motors designed for 480V operation. In such cases, the voltage levels used for shunting and DC bus overvoltage limits are adjusted to be compatible with the voltage limit of the motor.
- (3) The 2098-DSD-HVxxx-xx (460V) drives are limited to three contactor cycles per minute.
- (4) Power initialization requires a short period of inrush current (processor controlled via soft start circuitry). Dual element time delay (slow blow) fuses are recommended (refer to Fuse Specifications on [page 367](#)).
- (5) 400 µs half wave sine.

Fuse Specifications

Use class CC, G, J, L, R, or T fuses, with current ratings as indicated in the table below. The table below lists fuse examples recommended for use with the Ultra3000 (230V and 460V) drives.

Fuse Examples for Ultra3000 Drives

Drive Cat. No.	Input Voltage	Input Type	Recommended Fuse	
			Class CC ⁽¹⁾	Class J ⁽¹⁾
2098-DSD-005	230V AC	Input Power	FNQ-R-6	LPJ-6SP
2098-DSD-010			FNQ-R-10	LPJ-10SP
2098-DSD-020			FNQ-R-20	LPJ-20SP
2098-DSD-030			FNQ-R-30	LPJ-30SP
2098-DSD-075			FNQ-R-30	LPJ-30SP
2098-DSD-150			N/A	LPJ-60SP
2098-DSD-xxx		Auxiliary Input Power	FNQ-R-10	LPJ-10SP
2098-DSD-HV030	460V AC	Input Power	KTK-R-5	LPJ-5SP
2098-DSD-HV050			KTK-R-8	LPJ-8SP
2098-DSD-HV100			KTK-R-20	LPJ-17-1/2SP
2098-DSD-HV150			KTK-R-30	LPJ-30SP
2098-DSD-HV220			N/A	LPJ-35SP
2098-DSD-HVxxx		Auxiliary Input Power	FNQ-R-10	LPJ-10SP

(1) Part numbers shown are examples of Bussmann fuses.

Circuit Breaker Specifications

While circuit breakers offer some convenience, there are limitations for their use. Circuit breakers do not handle high current inrush as well as fuses.

Make sure the selected components are properly coordinated and meet acceptable codes including any requirements for branch circuit protection. Evaluation of the short-circuit available current is critical and must be kept below the short-circuit current rating of the circuit breaker.

Circuit Breaker Examples for Ultra3000 (460V) Drives

Drive Cat. No.	Input Voltage	Circuit Breakers
2098-DSD-HV030	460V	140M-F8E-C16
2098-DSD-HV050		140M-F8E-C20
2098-DSD-HV100		140M-F8E-C32
2098-DSD-HV150		140M-F8E-C45
2098-DSD-HV220		N/A

Contactors Ratings

Drive Cat. No.	Input Voltage	Contactors
2098-DSD-HV030	460V	100-C23x10 (AC coil) 100-C23Zx10 (DC coil)
2098-DSD-HV050		100-C30x10 (AC coil) 100-C30Zx10 (DC coil)
2098-DSD-HV100		100-C37x10 (AC coil) 100-C37Zx10 (DC coil)
2098-DSD-HV150		100-C43x10 (AC coil) 100-C43Zx10 (DC coil)
2098-DSD-HV220		100-C60x10 (AC coil) 100-C60Zx10 (DC coil)

Power Dissipation Specifications

Drive Cat. No.	Max Loss W
2098-DSD-005	48
2098-DSD-010	48
2098-DSD-020	50
2098-DSD-030	150 + dissipative shunt
2098-DSD-075	300 + dissipative shunt
2098-DSD-150	500 + dissipative shunt

Drive Cat. No.	Max Loss W
2098-DSD-HV030	175 + dissipative shunt
2098-DSD-HV050	175 + dissipative shunt
2098-DSD-HV100	350 + dissipative shunt
2098-DSD-HV150	350 + dissipative shunt
2098-DSD-HV220	600 + dissipative shunt

Communication Specifications

Attribute	Value
SERCOS (option)	
Communication rates	4 and 8 Mbps
Node addresses	01...99
DeviceNet (option)	
Power consumption from network	60 mA
Data rates	125, 250, and 500 kps, and auto-baud
Node addresses	00...63
Messaging capabilities	Explicit, Polled I/O, Change of State, and Cyclic Messaging
Serial	
Ports	One RS-232/RS-422/RS-485
Communication rates	1200, 2400, 4800, 9600, 19,200, and 38,400 bps

Inputs/Outputs Specifications

Attribute	Value
Digital inputs	8 optically isolated, 12...24V, active high, current sinking
Digital outputs	4 optically isolated, 12...24V, active high, current sourcing
Relay output	One normally open relay, 30V DC, max, 1 A, max
I/O response	100 μ s
Digital I/O firmware scan period	1 ms
Analog inputs COMMAND ILIMIT	14-bit A/D, \pm 10V 10-bit A/D, 0 to 10V
Analog output	\pm 10V, 8 bits, 2 mA max

Auxiliary Feedback Specifications

Attribute	Value
Input modes	A quad B, Step/Direction, CW/CCW
Maximum input frequency	2.5 MHz
Input types	Differential, single-ended, open collector ⁽¹⁾

(1) Differential input types are recommended.

Physical and Environmental Specifications

Attribute	Value	Attribute	Value
Weight, approx.		Weight, approx.	
2098-DSD-005	1.80 kg (4.1 lb)	2098-DSD-HV030	8.55 kg (18.8 lb)
2098-DSD-010	2.10 kg (4.6 lb)	2098-DSD-HV050	8.55 kg (18.8 lb)
2098-DSD-020	2.10 kg (4.6 lb)	2098-DSD-HV100	10.44 kg (22.9 lb)
2098-DSD-030	6.20 kg (13.6 lb)	2098-DSD-HV150	10.44 kg (22.9 lb)
2098-DSD-075	9.30 kg (20.6 lb)	2098-DSD-HV220	14.1 kg (31.0 lb)
2098-DSD-150	14.1 kg (31.0 lb)		
Temperature, ambient			
Operating	0...55 °C (32...131 °F)		
Storage	-40...70 °C (-40...158 °F)		
Relative humidity	5...95% noncondensing		
Altitude	1500 m (4921.5 ft) - Derate 3% per 300 m (984.3 ft) above 1500 m (4921.5 ft)		
Vibration	5...2000 Hz @ 2.5 g peak, 0.0006 mm (0.015 in.) max displacement		
Shock	15 g, 11 ms half-sine		

Connector Specifications

Connector	Description	Specification
CN1	User input/output	44-pin high-density female D-sub connector
CN2	Motor feedback connector	15-pin high-density female D-sub connector
CN3	Serial port connector	9-pin female D-sub connector
TB1 and TB2	Main and auxiliary AC, DC bus, motor power, and shunt connectors	Screw terminal block

Maximum Feedback Cable Lengths

Although motor feedback cables are available in standard lengths up to 90 m (295.3 ft), the drive/motor/feedback combination may limit the maximum cable length, as shown in the tables below. These tables assume the use of cables recommended in 2090-Series Motor/Actuator Cable Selection table on [page 402](#).

Maximum Cable Lengths for Compatible Rotary Motors

Motor Cat. No.	Absolute High-resolution (5V) Encoder m (ft)	Absolute High-resolution (9V) Encoder m (ft)	Incremental/TTL (5V) Encoder m (ft)
MPL-A15xxx...MPL-A2xxx-E/V	90 (295.3)		
MPL-A3xxx...MPL-A5xxx-S/M ⁽¹⁾	90 (295.3)		
MPL-B15xxx...MPL-B2xxx-E/V		90 (295.3)	
MPL-B3xxx...MPL-B9xxx-S/M		90 (295.3)	
MPL-A/B15xxx...MPL-A/B45xxx-H			45 (147.6)
MPM-Axxxx-S/M	30 (98.4)		
MPM-Bxxxx-S/M		90 (295.3)	
MPF-Axxxx-S/M ⁽¹⁾	90 (295.3)		
MPF-Bxxxx-S/M		90 (295.3)	
MPS-Axxxx-S/M	90 (295.3)		
MPS-Bxxxx-S/M		90 (295.3)	
TLY-Axxxx-H			30 (98.4)

(1) MPL-A5xxx and MPF-A5xxx motor encoders are rated for 9V, the remaining Bulletin MPL and MPF (230V) motor encoders are rated for 5V.

Maximum Cable Lengths for Compatible Linear Actuators

Actuator Cat. No.	Absolute High-resolution (5V) Encoder m (ft)	Absolute High-resolution (9V) Encoder m (ft)	Incremental/TTL (5V) Encoder m (ft)
MPMA-Axxxx or MPAS-Axxxx-V (ballscrew)	90 (295.3)		
MPMA-Axxxx or MPAS-Axxxx-A (direct drive)			45 (147.6)
MPMA-Bxxxx or MPAS-Bxxxx-V (ballscrew)		90 (295.3)	
MPMA-Bxxxx or MPAS-Bxxxx-A (direct drive)			45 (147.6)
MPAR-Axxxx-V/M	30 (98.4)		
MPAR-Bxxxx-V/M		90 (295.3)	
MPAI-AxxxxM3	30 (98.4)		
MPAI-BxxxxM3		90 (295.3)	

Maximum Cable Lengths for Compatible Linear Motors

Motor Cat. No.	Absolute High-resolution (5V) Encoder m (ft)	Incremental/TTL (5V) Encoder m (ft)
LDC-Series or LDL-Series	30 (98.4)	30 (98.4)

Ultra3000 Digital Servo Drive Dimensions

This section contains dimensions for the Ultra3000 digital servo drives (X indicates indexing, -SE indicates SERCOS interface, -DN indicates DeviceNet interface, and X-DN indicates indexing DeviceNet interface).

In the figure below, -xxx is replaced by -005, -010, or -020 to represent the Ultra3000 500 W, 1 kW, and 2 kW drives respectively.

2098-DSD-xxx, 2098-DSD-xxxX, 2098-DSD-xxx-SE, 2098-DSD-xxx-DN, 2098-DSD-xxxX-DN Dimensions (230V)

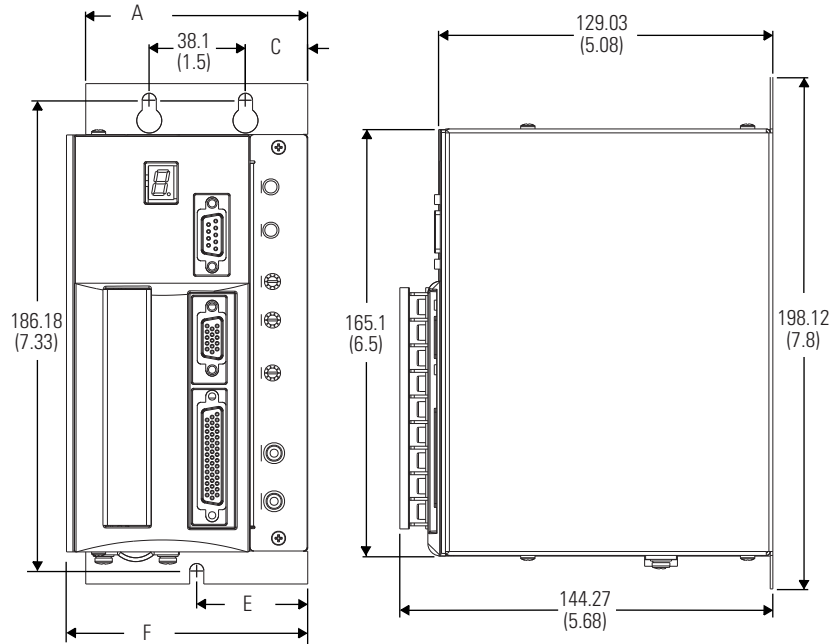

Dimensions are in mm (in.)
Unit shown is the 2098-DSD-005-SE

Ultra3000 Drives	A mm (in.)	C mm (in.)	E mm (in.)	F mm (in.)
2098-DSD-005, 2098-DSD-005X	65.02 (2.56)	13.26 (0.52)	32.77 (1.29)	72.64 (2.86)
2098-DSD-010, 2098-DSD-010X, 2098-DSD-020, 2098-DSD-020X				98.1 (3.89)
2098-DSD-005-SE, 2098-DSD-005-DN, 2098-DSD-005X-DN	87.88 (3.46)	24.64 (0.97)	43.94 (1.73)	95.5 (3.76)
2098-DSD-010-SE, 2098-DSD-010-DN, 2098-DSD-010X-DN, 2098-DSD-020-SE, 2098-DSD-020-DN, 2098-DSD-020X-DN				121.54 (4.79)

In the figure below, -xxx is replaced by -030, -075, or -150 to represent the Ultra3000 3, 7.5, and 15 kW drives respectively.

2098-DSD-xxx, 2098-DSD-xxxX, 2098-DSD-xxx-SE, 2098-DSD-xxx-DN, 2098-DSD-xxxX-DN Dimensions (230V)

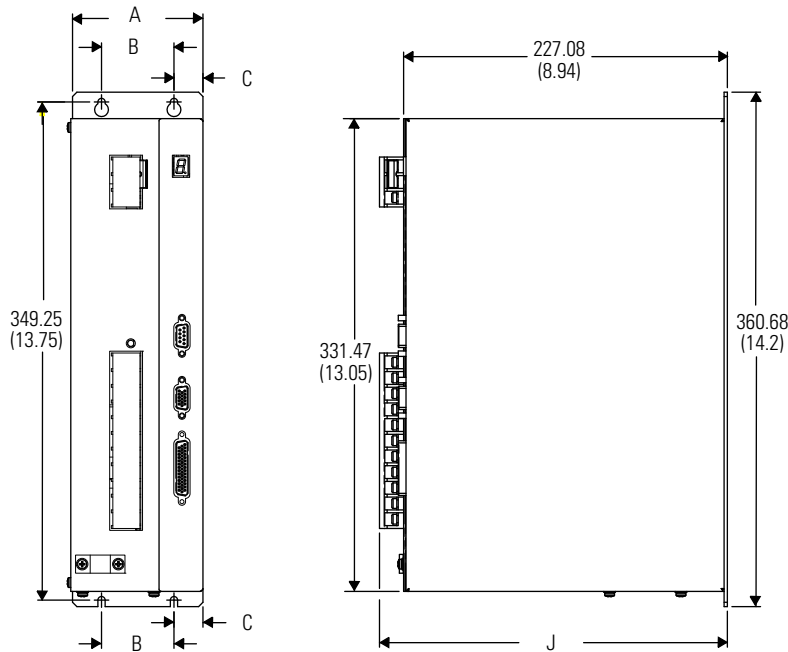

Dimensions are in mm (in.)
Unit shown is the 2098-DSD-030

Ultra3000 Drives	A mm (in.)	B mm (in.)	C mm (in.)	J mm (in.)
2098-DSD-030, 2098-DSD-030X, 2098-DSD-030-SE, 2098-DSD-030-DN, 2098-DSD-030X-DN	91.44 (3.6)	50.8 (2.0)	20.32 (0.8)	243.84 (9.6)
2098-DSD-075, 2098-DSD-075X, 2098-DSD-075-SE, 2098-DSD-075-DN, 2098-DSD-075X-DN	138.68 (5.41)	88.9 (3.5)	24.89 (0.96)	247.14 (9.73)
2098-DSD-150, 2098-DSD-150X, 2098-DSD-150-SE, 2098-DSD-150-DN, 2098-DSD-150X-DN	188.97 (7.44)	139.7 (5.5)	24.6 (0.97)	241.05 (9.49)

In the figure below, *xxx* is replaced by 030, 050, 100, 150, or 220 to represent the Ultra3000 3, 5, 10, 15, and 22 kW drives respectively.

2098-DSD-HV_{xxx}, 2098-DSD-HV_{xxx}X, 2098-DSD-HV_{xxx}-SE, 2098-DSD-HV_{xxx}-DN, 2098-DSD-HV_{xxx}X-DN Dimensions (460V)

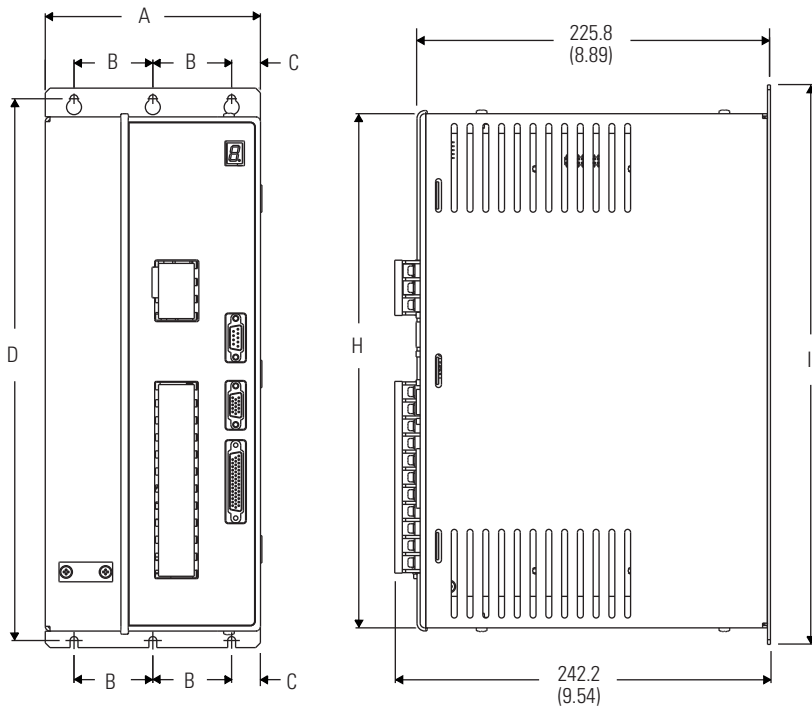

Dimensions are in mm (in.)

Unit shown is the 2098-DSD-HV030

Ultra3000 Drives (1)	A mm (in.)	C mm (in.)	B mm (in.)	D mm (in.)	H mm (in.)	I mm (in.)
2098-DSD-HV030 _x , 2098-DSD-HV030- _{xx} , 2098-DSD-HV050 _x , 2098-DSD-HV050- _{xx}	138.7 (5.46)	18.5 (0.73)	50.8 (2.0)	349.3 (13.75)	331.5 (13.05)	360.7 (14.2)
2098-DSD-HV100 _x , 2098-DSD-HV100- _{xx} , 2098-DSD-HV150 _x , 2098-DSD-HV150- _{xx}	151.6 (5.97)	25 (0.99)				
2098-DSD-HV220 _x , 2098-DSD-HV220- _{xx}	203.2 (8.0)	25.4 (1.0)	76.2 (3.0)	380.4 (14.98)	362.6 (14.26)	391.8 (15.43)

(1) The *x* represents the indexing (X) option. The *-xx* represents the SERCOS interface (SE) or DeviceNet interface (DN) option. SERCOS interface is not available with the DeviceNet interface option.

Ultra3000 Connector, Indicator, and Switch Locations

This section provides the connector, indicator, and switch locations for the Ultra3000 Digital Servo Drives (X indicates indexing, -SE indicates SERCOS interface, -DN indicates DeviceNet interface, and X-DN indicates indexing DeviceNet interface).

2098-DSD-005, 2098-DSD-010, 2098-DSD-020 Ultra3000 (230V) Connectors

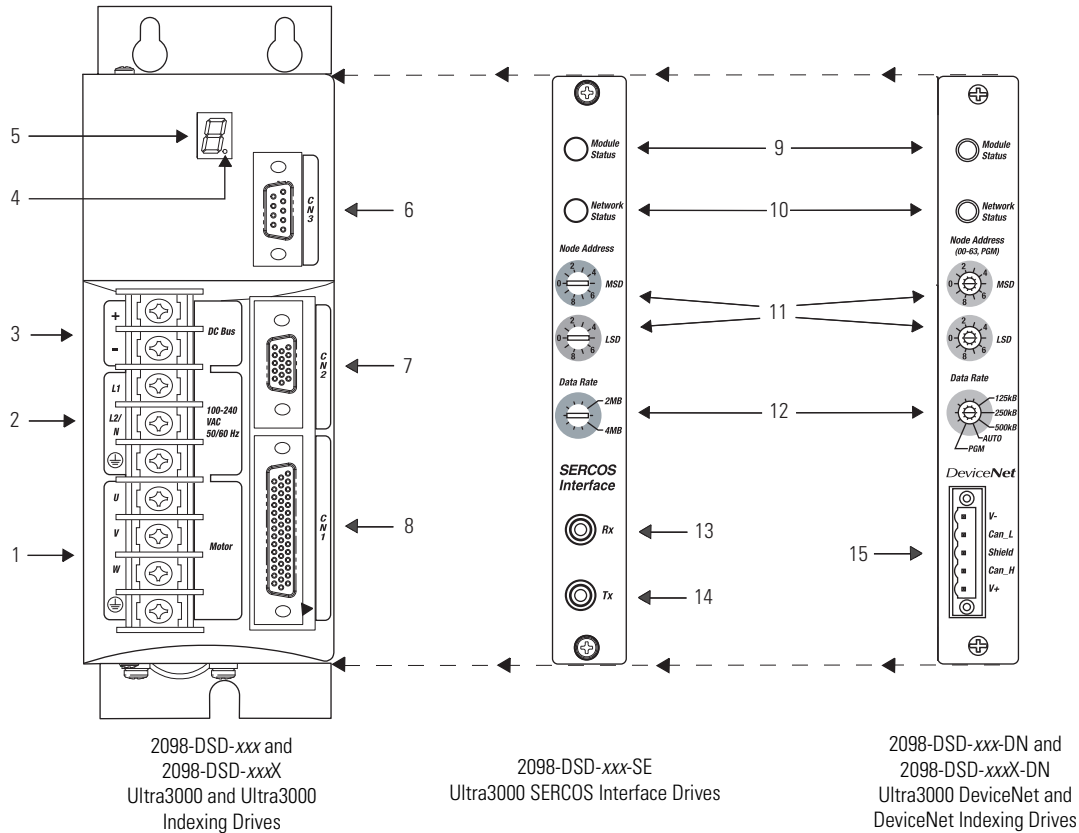

Item	Description
1	Motor power connections
2	AC input power connections
3	DC bus connections for active shunt resistor kit
4	Logic power
5	Seven-segment fault status indicator

Item	Description
6	CN3 9-pin serial port connector
7	CN2 15-pin motor feedback connector
8	CN1 44-pin user I/O connector
9	Module status indicator
10	Network status indicator

Item	Description
11	SERCOS node address switches
12	Data rate switch
13	SERCOS receive (Rx) connector
14	SERCOS transmit (Tx) connector
15	DeviceNet interface connector

For CN1, CN2, and CN3 connector options, refer to Breakout Components and Connector Kits beginning on [page 442](#).

2098-DSD-030, 2098-DSD-075, and 2098-DSD-150 Ultra3000 (230V) Connectors

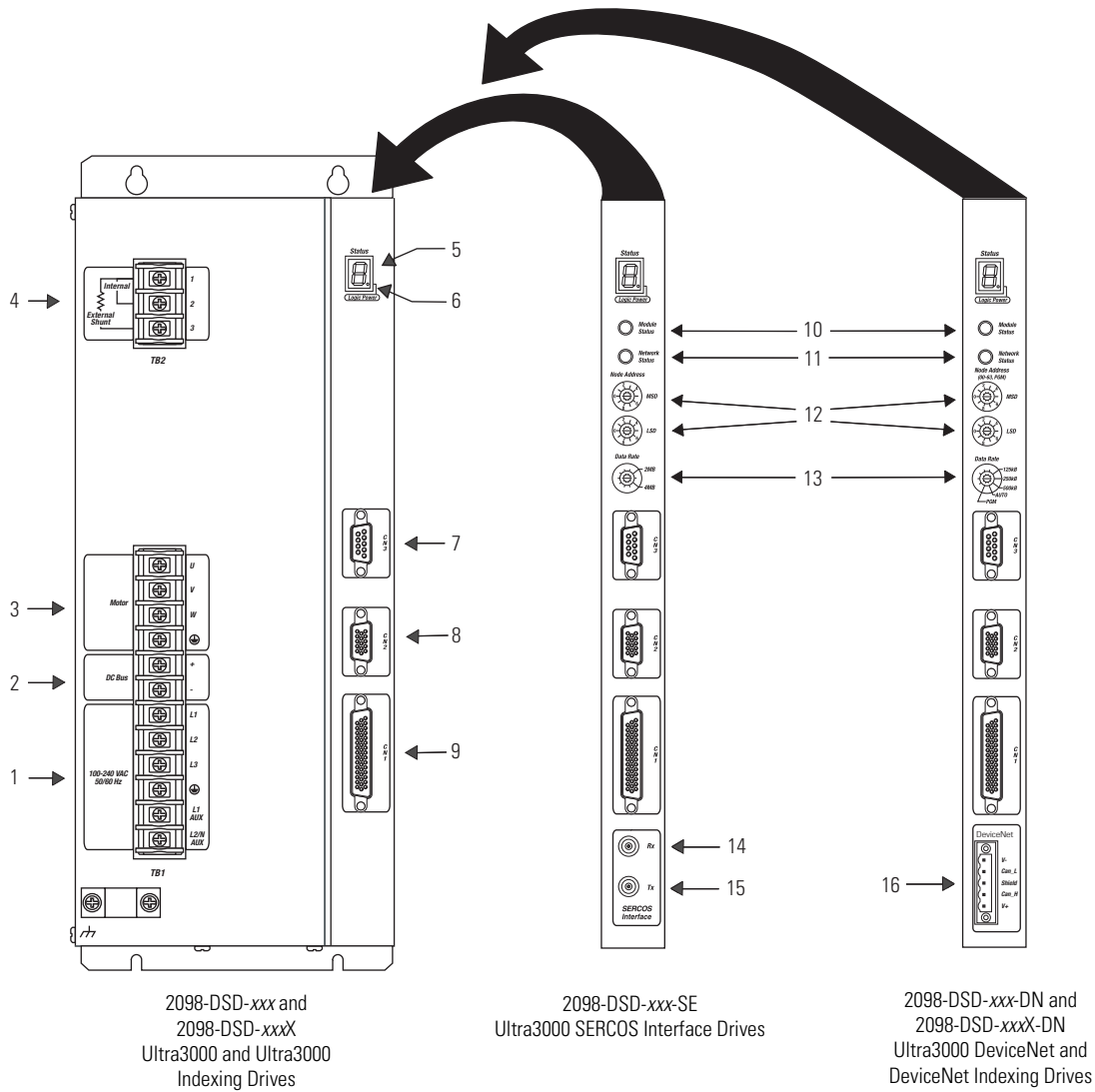

Item	Description
1	AC input power connections ⁽¹⁾
2	DC bus connections for active shunt resistor kit
3	Motor power connections
4	Passive shunt resistor connections
5	Seven-segment fault status indicator
6	Logic power
7	CN3 9-pin serial port connector
8	CN2 15-pin motor feedback connector

(1) The 2098-DSD-030x-xx drives do not have an L3 power terminal.

Item	Description
9	CN1 44-pin user I/O connector
10	Module status indicator
11	Network status indicator
12	SERCOS node address switches
13	Data rate switch
14	SERCOS receive (Rx) connector
15	SERCOS transmit (Tx) connector
16	DeviceNet interface connector

For CN1, CN2, and CN3 connector options, refer to Breakout Components and Connector Kits beginning on [page 442](#).

2098-DSD-HV030, 2098-DSD-HV050, 2098-DSD-HV100, 2098-DSD-HV150, and 2098-DSD-HV220 Ultra3000 (460V) Connectors

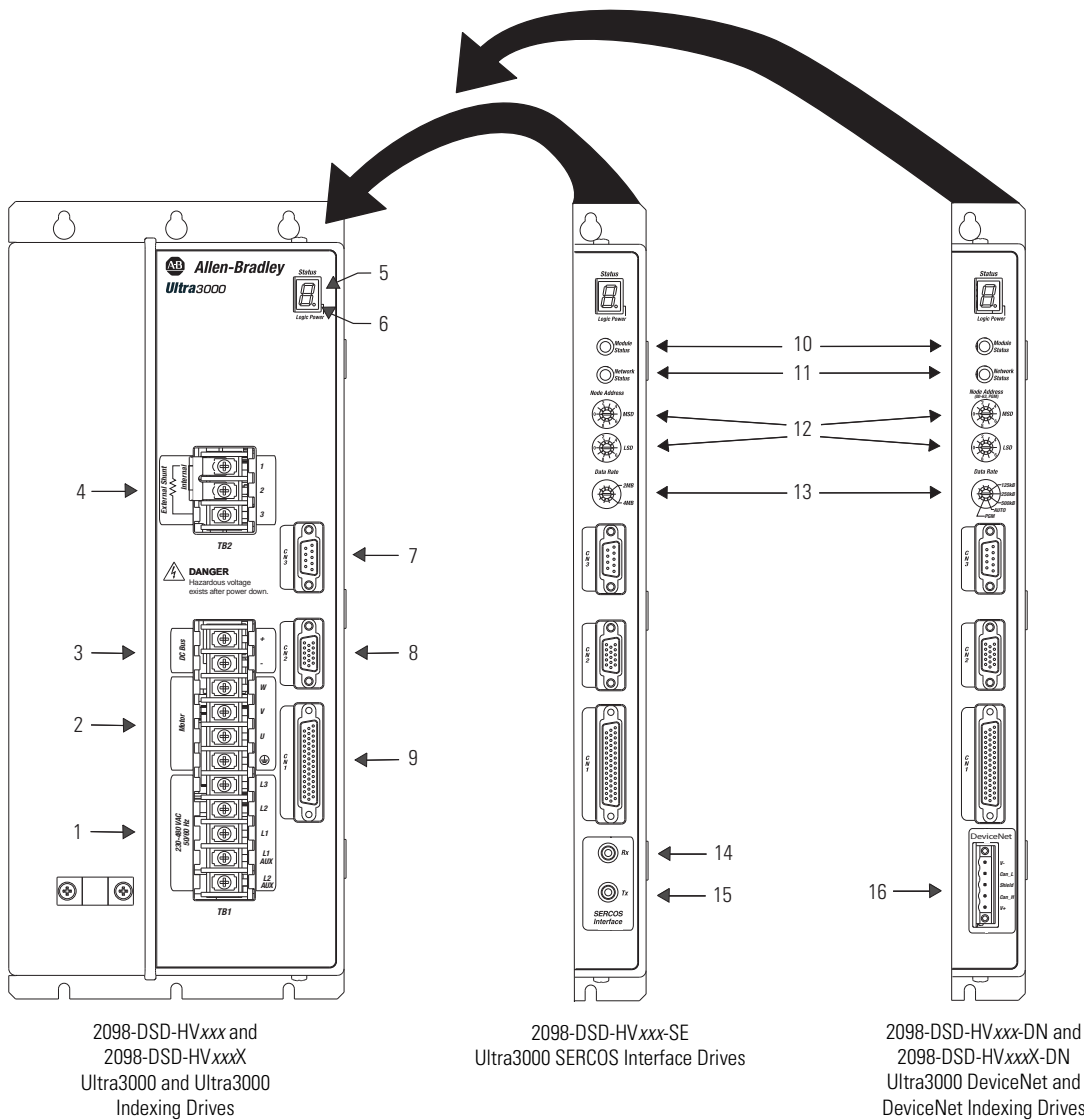

Item	Description
1	AC input power connections
2	DC bus connections for active shunt resistor kit
3	Motor power connections
4	Passive shunt resistor connections
5	Seven-segment fault status indicator
6	Logic power
7	CN3 9-pin serial port connector
8	CN2 15-pin motor feedback connector

Item	Description
9	CN1 44-pin user I/O connector
10	Module status indicator
11	Network status indicator
12	SERCOS node address switches
13	Data rate switch
14	SERCOS receive (Rx) connector
15	SERCOS transmit (Tx) connector
16	DeviceNet interface connector

For CN1, CN2, and CN3 connector options, refer to Breakout Components and Connector Kits beginning on [page 442](#).

Ultra3000 Digital Servo Drive Catalog Numbers

Catalog numbers consist of various characters, each of which identifies a specific option for that component. Use the catalog numbering chart below to understand the configuration of your drive. For questions regarding product availability, contact your Allen-Bradley distributor.

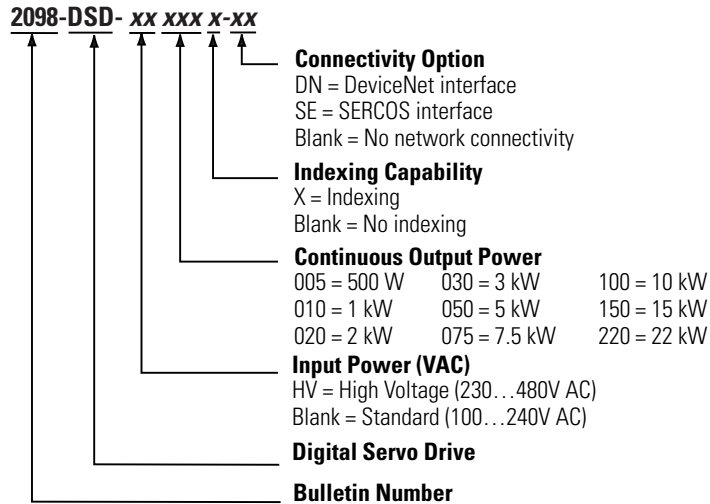

Ultraware Software Catalog Number

Ultra3000, Ultra3000 with indexing, Ultra3000-DN, and Ultra3000-DN with indexing drives are configured by using Ultraware software (catalog number 2098-UWCPRG). The Ultra3000-SE drives are configured by using RSLogix 5000 software.

Notes: