

Mechanically Jointed Rodless Cylinder

Series MY1



- MY1B
- MY1M
- MY1C
- MY1H
- MY1HT
- MY1□W
- MY2C
- MY2H□
- MY3A
- MY3B
- MY3M

Five types of guide allow a wide range of selections.

Series Variations		Piping type ⁽¹⁾	Bore size (mm)								Air cushion ⁽²⁾	Stroke adjusting Unit	Side support	Floating bracket	End lock	Made to Order ⁽³⁾	P. 951	
Series	Guide type		10	16	20	25	32	40	50	63								80
MY1B	Basic type	Centralized piping Standard piping	●	●	●	●	●	●	●	●	●	●	●	●	●	●	P. 951	
MY1M	Slide bearing guide type		●	●	●	●	●	●	●	●	●	●	●	●	●	●	●	P. 975
MY1C	Cam follower guide type		●	●	●	●	●	●	●	●	●	●	●	●	●	●	●	P. 995
MY1H	Linear guide type		●	●	●	●	●	●	●	●	●	●	●	●	●	●	●	P. 1015
MY1HT	High rigidity/Linear guide type		●	●	●	●	●	●	●	●	●	●	●	●	●	●	●	P. 1039

Note 1) $\phi 10$ is available with central piping only. Note 2) $\phi 10$ is available with rubber bumper only.
 Note 3) Availability for made-to-order differs, depending on the size and the model.

- D-□
- X□
- Individual -X□
- Technical data

Mechanically Jointed Rodless Cylinder **MY1 Series**

Basic type

MY1B Series

Can be combined with a variety of guides to accommodate conditions. Simple design without guide facilitates space savings.

Basic type

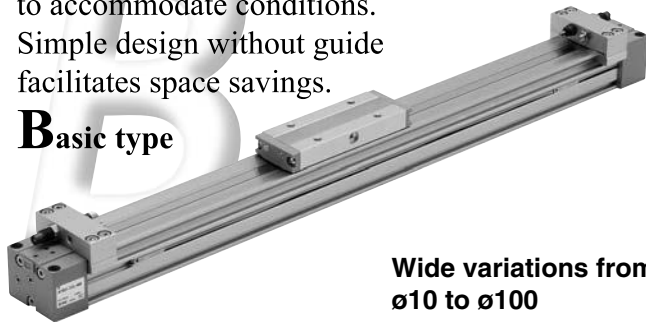

Wide variations from $\phi 10$ to $\phi 100$

Slide bearing type

MY1M Series

Integral guide allows use in a wide range of conveyor systems.

Moderate type

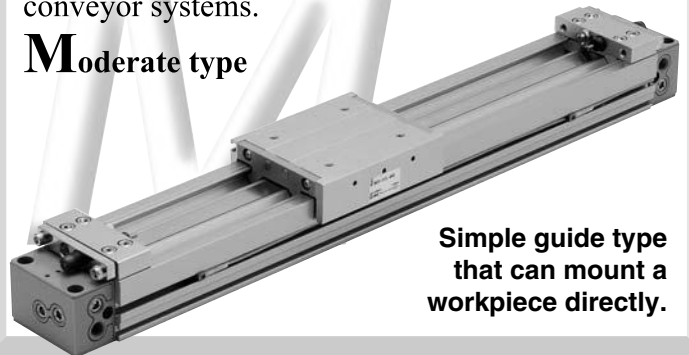

Simple guide type that can mount a workpiece directly.

Cam follower guide type

MY1C Series

Makes smooth operation possible even with an off-set load.

Cam follower type

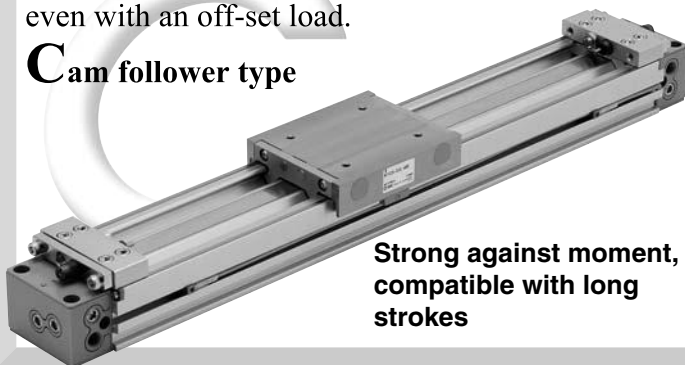

Strong against moment, compatible with long strokes

Linear guide type

MY1H Series

Small and medium sizes $\phi 10$ to $\phi 40$ are ideal for pick & place.

High precision type

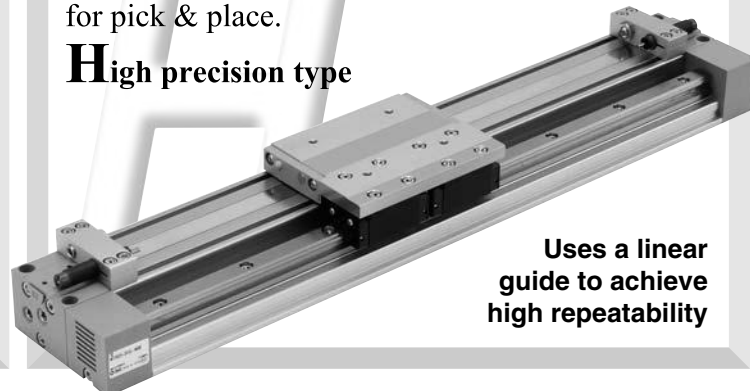

Uses a linear guide to achieve high repeatability

High rigidity/Linear guide type

MY1HT Series

Heavy load, high moment
Ideal for transfer and pick & place of heavy loaded workpieces

High precision Twin guide type



Linear guide
Heavy loaded workpieces can be accommodated by using two linear guides.

Stroke availability

Strokes may be selected in increments of 1 mm.

Stroke adjusting unit

Strokes can be adjusted either at one side or both sides.

- Adjusting bolt
- Low load shock absorber + Adjusting bolt (L unit)
- Heavy-loaded shock absorber + Adjusting bolt (H unit)

Centralized piping

Piping ports are concentrated at one side.

Side support

Side support prevents a cylinder tube from sagging in long stroke applications.

Interchangeability

The bodies and workpiece mountings are interchangeable between Series MY1M and MY1C.



Basic type MY1B10

Height **27** mm

Linear guide type MY1H10



- Even when equipped with a floating bracket, the height is only 28.5 mm.

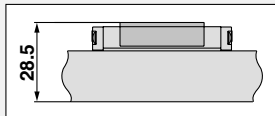

<Scale:100%>

- The stroke adjusting unit (H unit) does not protrude above the table type.

- Stroke adjusting unit can be mounted
- Centralized piping type (Standard)

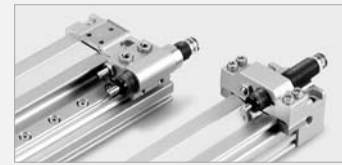

MY1B

MY1M

MY1C

MY1H

MY1HT

MY1□W

MY2C

MY2H□

MY3A

MY3B

MY3M



Uses two linear guides.
Maximum load mass of 320 kg. (ø63)

High rigidity/Linear guide type **MY1HT50/63**

Extremely easy to maintain

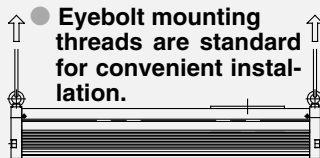

- Eyebolt mounting threads are standard for convenient installation.

Using eyebolts

- It is possible to replace cylinders with a workpiece being mounted.

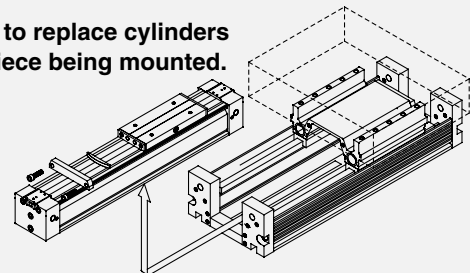

End lock type introduced to series MY1H.

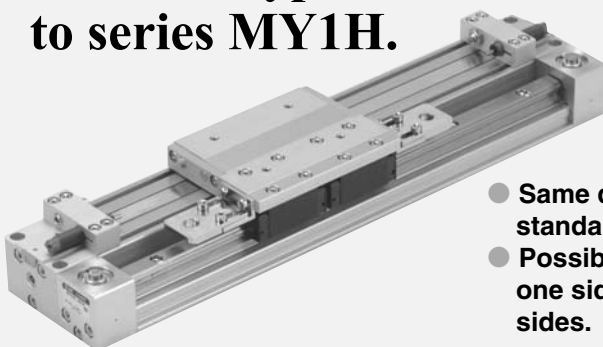

- Same dimensions as standard
- Possible to lock either on one side or on both sides.

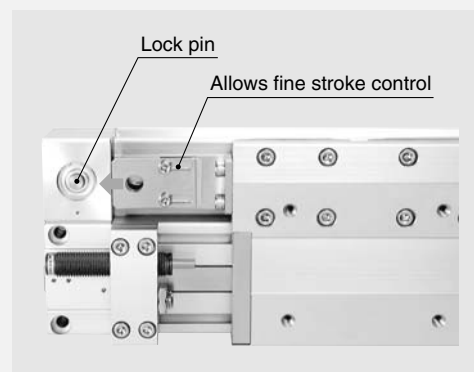

Lock pin

Allows fine stroke control

D-□

-X□

Individual
-X□

Technical
data

Series MY1 Model Selection 1

Following are the steps for selecting the most suitable Series MY1 to your application.

Standards for Tentative Model Selection

Cylinder model	Guide type	Standards for guide selection	Graphs for related allowable values
MY1B	Basic type	Guaranteed accuracy not required, generally combined with separate guide	Refer to P. 952.
MY1M	Slide bearing guide type	Slide table accuracy approx. ± 0.12 mm ⁽²⁾	Refer to P. 976.
MY1C	Cam follower guide type	Slide table accuracy approx. ± 0.05 mm ⁽²⁾	Refer to P. 996.
MY1H	Linear guide type	Slide table accuracy of ± 0.05 mm or less required ⁽²⁾	Refer to P. 1016.
MY1HT	High rigidity/Linear guide type	Slide table accuracy of ± 0.05 mm or less required ⁽²⁾	Refer to P. 1040.

Note 1) These accuracy values for each guide should be used only as a guide during selection. Please contact SMC when guaranteed accuracy for MY1C/MY1H is required.

Note 2) "Accuracy" here means displacement of the slide table (at stroke end) when 50% of the allowable moment shown in the catalog is applied. (reference value).

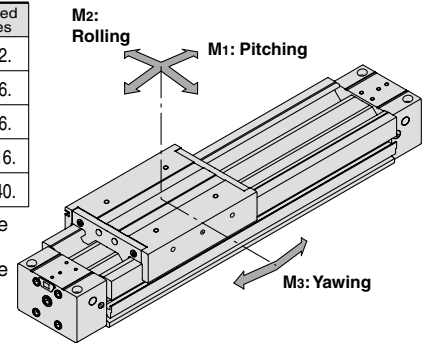

Selection Flow Chart

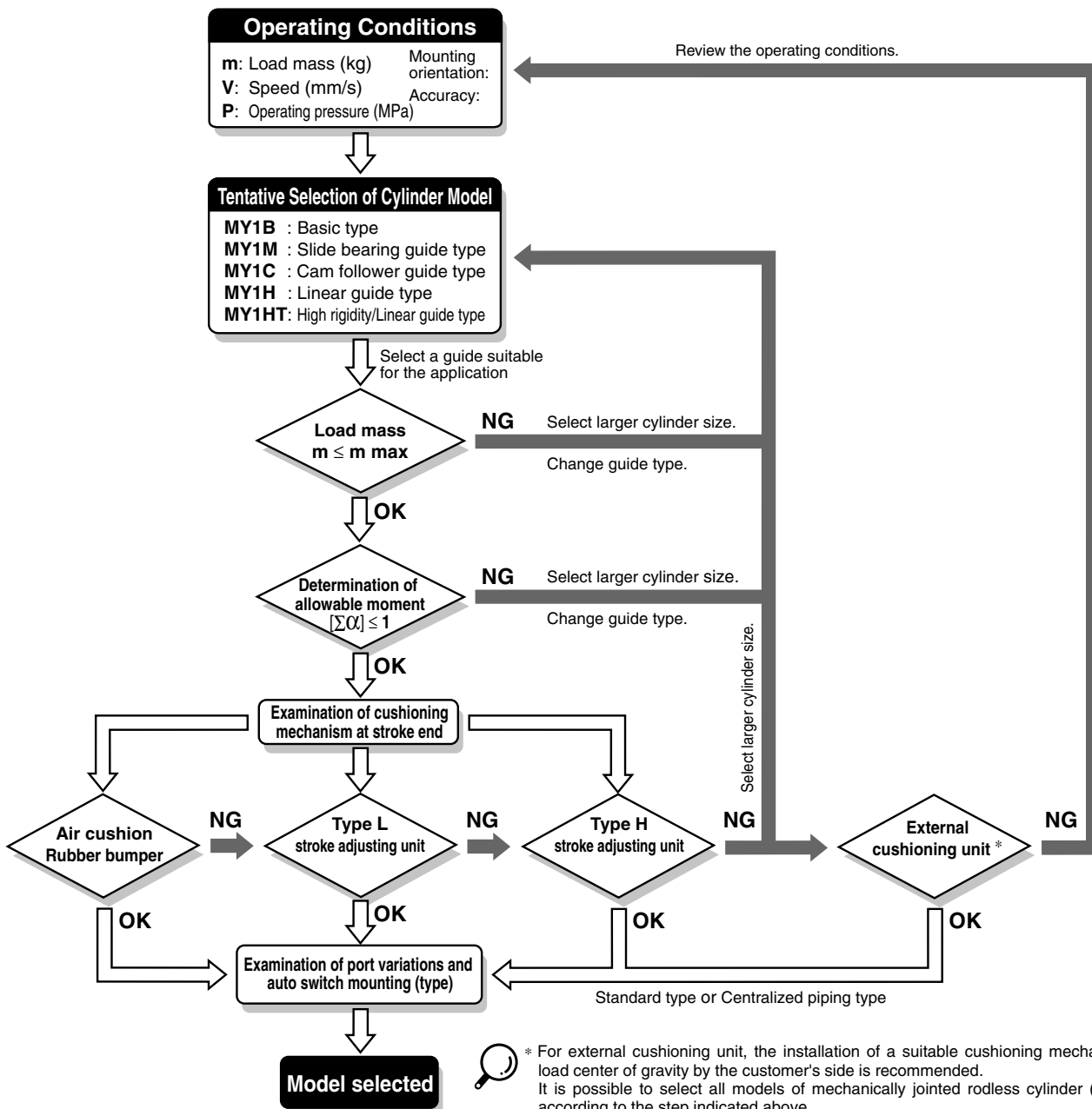

Types of Moment Applied to Rodless Cylinders

Multiple moments may be generated depending on the mounting orientation, load, and position of the center of gravity.

Coordinates and Moments

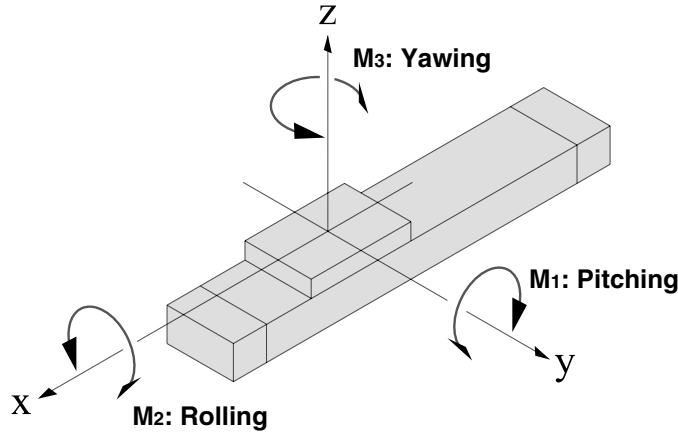

Static Moment

Horizontal mounting

Ceiling mounting

Wall mounting

Vertical mounting

g: Gravitational acceleration

Mounting orientation	Horizontal mounting	Ceiling mounting	Wall mounting	Vertical mounting
Static load (m)	m_1	m_2	m_3	m_4 (Note)
Static moment				
M_1	$m_1 \times g \times X$	$m_2 \times g \times X$	—	$m_4 \times g \times Z$
M_2	$m_1 \times g \times Y$	$m_2 \times g \times Y$	$m_3 \times g \times Z$	—
M_3	—	—	$m_3 \times g \times X$	$m_4 \times g \times Y$

Note) m_4 is a mass movable by thrust. Use 0.3 to 0.7 times the thrust (differs depending on the operating speed) as a guide for actual use.

Dynamic Moment

Mounting orientation	Horizontal mounting	Ceiling mounting	Wall mounting	Vertical mounting
Dynamic load (FE)	$1.4 \cup a \times \delta \times m_n \times g$			
Dynamic moment				
M_{1E}		$\frac{1}{3} \times FE \times Z$		
M_{2E}	Dynamic moment M_{2E} is not generated.			
M_{3E}			$\frac{1}{3} \times FE \times Y$	

Note) Regardless of the mounting orientation, dynamic moment is calculated with the formulae above.

g: Gravitational acceleration, $\cup a$: Average speed, δ : Damper coefficient

- MY1B
- MY1M
- MY1C
- MY1H
- MY1HT
- MY1W
- MY2C
- MY2H
- MY3A
- MY3B
- MY3M

- D-□
- X□
- Individual -X□
- Technical data

Series MY1 Model Selection 2

Following are the steps for selecting the most suitable Series MY1 to your application.

Calculation of Guide Load Factor

1. Operating Conditions

Operating cylinder MY1H40-500
 Average operating speed v_a ... 300 mm/s
 Mounting orientation Wall mounting
 Cushion Air cushion ($\delta = 1/100$)

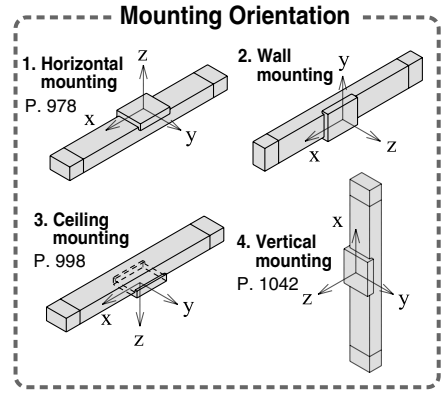
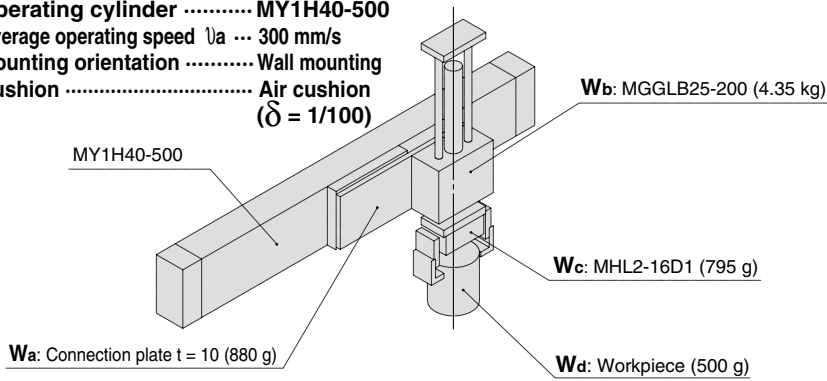

For actual examples of calculation for each orientation, refer to the pages above.

2. Load Blocking

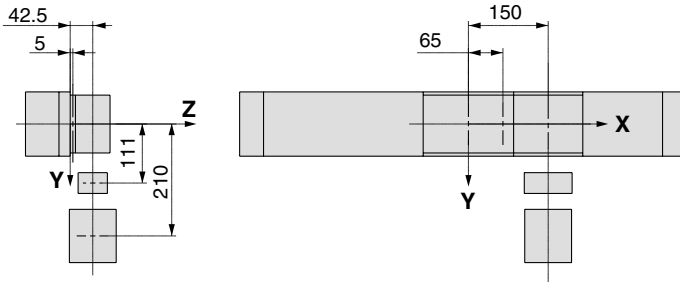

Mass and Center of Gravity for Each Workpiece

Workpiece no. W_n	Mass m_n	Center of gravity		
		X-axis X_n	Y-axis Y_n	Z-axis Z_n
W_a	0.88 kg	65 mm	0 mm	5 mm
W_b	4.35 kg	150 mm	0 mm	42.5 mm
W_c	0.795 kg	150 mm	111 mm	42.5 mm
W_d	0.5 kg	150 mm	210 mm	42.5 mm

n = a, b, c, d

3. Composite Center of Gravity Calculation

$$m_3 = \sum m_n = 0.88 + 4.35 + 0.795 + 0.5 = 6.525 \text{ kg}$$

$$X = \frac{1}{m_3} \times \sum (m_n \times X_n) = \frac{1}{6.525} (0.88 \times 65 + 4.35 \times 150 + 0.795 \times 150 + 0.5 \times 150) = 138.5 \text{ mm}$$

$$Y = \frac{1}{m_3} \times \sum (m_n \times Y_n) = \frac{1}{6.525} (0.88 \times 0 + 4.35 \times 0 + 0.795 \times 111 + 0.5 \times 210) = 29.6 \text{ mm}$$

$$Z = \frac{1}{m_3} \times \sum (m_n \times Z_n) = \frac{1}{6.525} (0.88 \times 5 + 4.35 \times 42.5 + 0.795 \times 42.5 + 0.5 \times 42.5) = 37.4 \text{ mm}$$

4. Calculation of Load Factor for Static Load

m₃: Mass

m₃ max (from (1) of graph MY1H/m₃) = 50 (kg)

Load factor $\alpha_1 = m_3 / m_{3 \text{ max}} = 6.525 / 50 = 0.13$

M₂: Moment

M₂ max (from (2) of graph MY1H/M₂) = 50 (N·m)

M₂ = **m₃** × **g** × **Z** = 6.525 × 9.8 × 37.4 × 10⁻³ = 2.39 (N·m)

Load factor $\alpha_2 = M_2 / M_{2 \text{ max}} = 2.39 / 50 = 0.05$

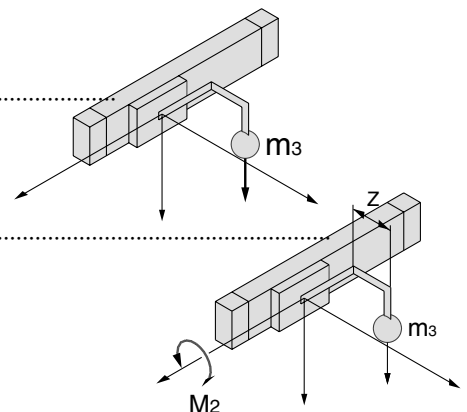

M₃: Moment

M₃ max (from (3) of graph MY1H/M₃) = 38.7 (N·m)

$$M_3 = m_3 \times g \times X = 6.525 \times 9.8 \times 138.5 \times 10^{-3} = 8.86 \text{ (N·m)}$$

$$\text{Load factor } \alpha_3 = M_3 / M_3 \text{ max} = 8.86 / 38.7 = 0.23$$

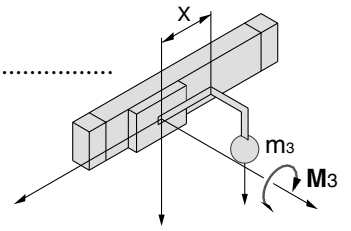

5. Calculation of Load Factor for Dynamic Moment

Equivalent load F_E at impact

$$F_E = 1.4 \nu_a \times \delta \times m \times g = 1.4 \times 300 \times \frac{1}{100} \times 6.525 \times 9.8 = 268.6 \text{ (N)}$$

M_{1E}: Moment

M_{1E} max (from (4) of graph MY1H/M₁ where 1.4ν_a = 420 mm/s) = 35.9 (N·m)

$$M_{1E} = \frac{1}{3} \times F_E \times Z = \frac{1}{3} \times 268.6 \times 37.4 \times 10^{-3} = 3.35 \text{ (N·m)}$$

$$\text{Load factor } \alpha_4 = M_{1E} / M_{1E} \text{ max} = 3.35 / 35.9 = 0.09$$

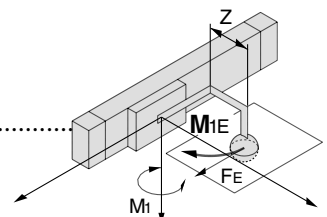

M_{3E}: Moment

M_{3E} max (from (5) of graph MY1H/M₃ where 1.4ν_a = 420 mm/s) = 27.6 (N·m)

$$M_{3E} = \frac{1}{3} \times F_E \times Y = \frac{1}{3} \times 268.6 \times 29.6 \times 10^{-3} = 2.65 \text{ (N·m)}$$

$$\text{Load factor } \alpha_5 = M_{3E} / M_{3E} \text{ max} = 2.65 / 27.6 = 0.10$$

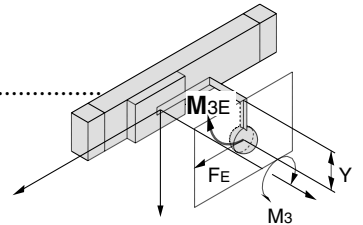

6. Sum and Examination of Guide Load Factors

$$\sum \alpha = \alpha_1 + \alpha_2 + \alpha_3 + \alpha_4 \times \alpha_5 = 0.60 \leq 1$$

The above calculation is within the allowable value, and therefore the selected model can be used.

Select a shock absorber separately.

In an actual calculation, when the sum of guide load factors $\sum \alpha$ in the formula above is more than 1, consider decreasing the speed, increasing the bore size, or changing the product series.

This calculation can be easily made using the "SMC Pneumatics CAD System".

Load Mass

MY1H/m₃

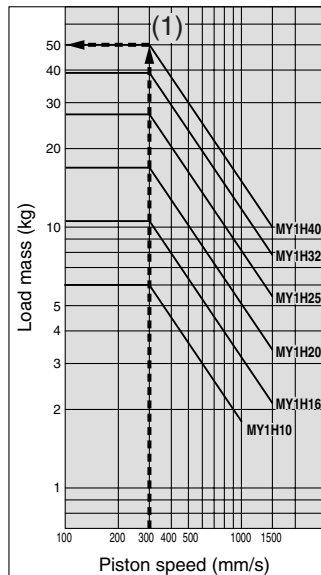

Allowable Moment

MY1H/M₁

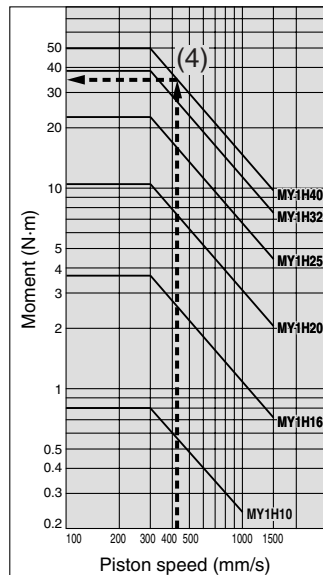

MY1H/M₂

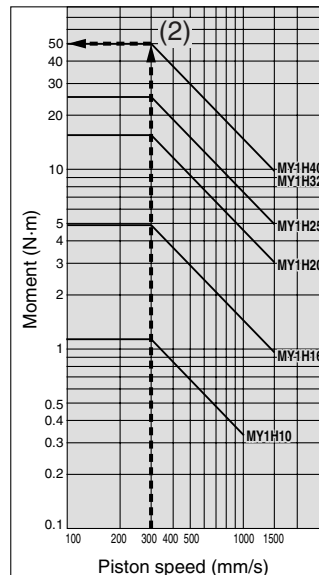

MY1H/M₃

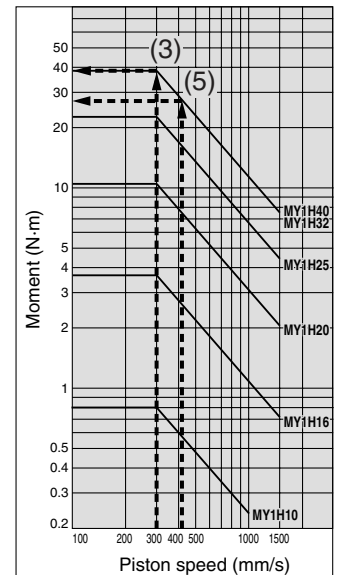

MY1B

MY1M

MY1C

MY1H

MY1HT

MY1□W

MY2C

MY2H□

MY3A

MY3B

MY3M

D-□

-X□

Individual

-X□

Technical data

Series MY1B

Basic Type

ø10, ø16, ø20, ø25, ø32, ø40, ø50, ø63, ø80, ø100

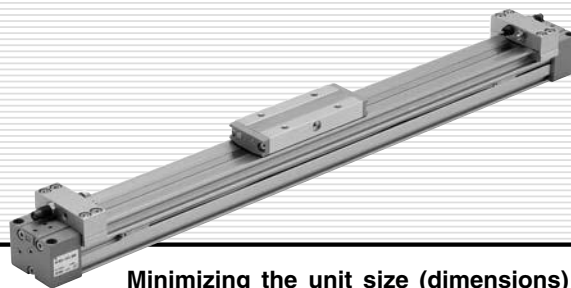

Minimizing the unit size (dimensions) and combination with other guides is possible.

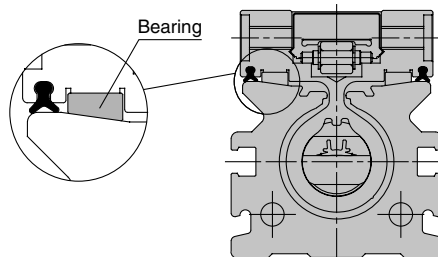

MY1B

MY1M

MY1C

MY1H

MY1HT

MY1□W

MY2C

MY2H□

MY3A
MY3B

MY3M

D-□

-X□

Individual
-X□

Technical
data

Maximum Allowable Moment/Maximum Load Mass

Model	Bore size (mm)	Maximum allowable moment (N·m)			Maximum load mass (kg)		
		M ₁	M ₂	M ₃	m ₁	m ₂	m ₃
MY1B	10	0.8	0.1	0.3	5.0	1.0	0.5
	16	2.5	0.3	0.8	15	3.0	1.7
	20	5.0	0.6	1.5	21	4.2	3.0
	25	10	1.2	3.0	29	5.8	5.4
	32	20	2.4	6.0	40	8.0	8.8
	40	40	4.8	12	53	10.6	14
	50	78	9.3	23	70	14	20
	63	160	19	48	83	16.6	29
	80	315	37	95	120	24	42
100	615	73	184	150	30	60	

The above values are the maximum allowable values for moment and load. Refer to each graph regarding the maximum allowable moment and maximum allowable load for a particular piston speed.

Caution on Design

We recommend installing an external shock absorber when the cylinder is combined with another guide (connection with floating bracket, etc.) and the maximum allowable load is exceeded, or when the operating speed is 1000 to 1500 mm/s for bore sizes ø16, ø50, ø63, ø80 and ø100.

Load mass (kg)

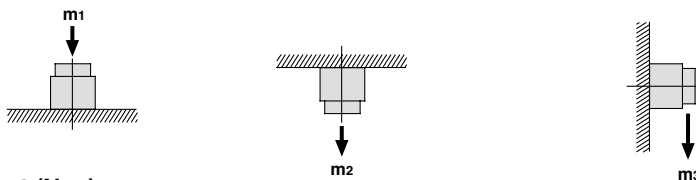

Moment (N·m)

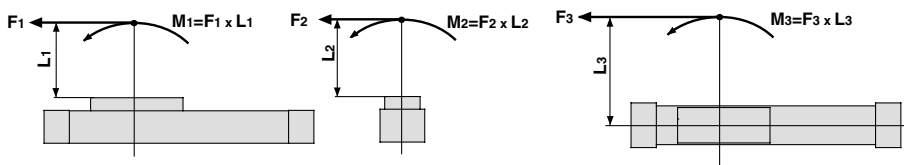

<Calculation of guide load factor>

1. Maximum allowable load (1), static moment (2), and dynamic moment (3) (at the time of impact with stopper) must be examined for the selection calculations.

* To evaluate, use \bar{v}_a (average speed) for (1) and (2), and v (collision speed $v = 1.4 \bar{v}_a$) for (3). Calculate m_{max} for (1) from the maximum allowable load graph (m_1, m_2, m_3) and M_{max} for (2) and (3) from the maximum allowable moment graph (M_1, M_2, M_3).

$$\text{Sum of guide load factors } \Sigma \alpha = \frac{\text{Load mass [m]}}{\text{Maximum allowable load [m}_{max}]} + \frac{\text{Static moment [M]}^{(1)}}{\text{Allowable static moment [M}_{max}]} + \frac{\text{Dynamic moment [M}_E]^{(2)}}{\text{Allowable dynamic moment [M}_{Emax}]} \leq 1$$

Note 1) Moment caused by the load, etc., with cylinder in resting condition.

Note 2) Moment caused by the impact load equivalent at the stroke end (at the time of impact with stopper).

Note 3) Depending on the shape of the workpiece, multiple moments may occur. When this happens, the sum of the load factors ($\Sigma \alpha$) is the total of all such moments.

2. Reference formula [Dynamic moment at impact]

Use the following formulae to calculate dynamic moment when taking stopper impact into consideration.

m: Load mass (kg)

F: Load (N)

F_E: Load equivalent to impact (at impact with stopper) (N)

\bar{v}_a : Average speed (mm/s)

M: Static moment (N·m)

$\bar{v} = 1.4 \bar{v}_a$ (mm/s) $F_E = 1.4 \bar{v}_a \delta \cdot m \cdot g$ ^{Note 4)}

$\therefore M_E = \frac{1}{3} F_E \cdot L_1 = 4.57 \bar{v}_a \delta m L_1$ ^{Note 5)}

v: Collision speed (mm/s)

L₁: Distance to the load's center of gravity (m)

M_E: Dynamic moment (N·m)

δ : Damper coefficient

With rubber bumper = 4/100

(MY1B10, MY1H10)

With air cushion = 1/100

With shock absorber = 1/100

g: Gravitational acceleration (9.8 m/s²)

Note 4) $1.4 \bar{v}_a \delta$ is a dimensionless coefficient for calculating impact force.

Note 5) Average load coefficient ($= \frac{1}{3}$): This coefficient is for averaging the maximum load moment at the time of stopper impact according to service life calculations.

3. For detailed selection procedures, refer to pages 954 and 955.

Maximum Allowable Moment

Select the moment from within the range of operating limits shown in the graphs. Note that the maximum allowable load value may sometimes be exceeded even within the operating limits shown in the graphs. Therefore, also check the allowable load for the selected conditions.

Maximum Load Mass

Select the load from within the range of limits shown in the graphs. Note that the maximum allowable moment value may sometimes be exceeded even within the operating limits shown in the graphs. Therefore, also check the allowable moment for the selected conditions.

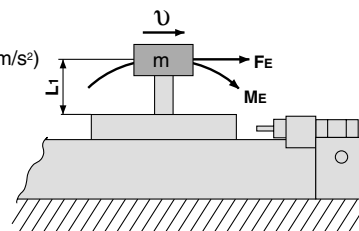

MY1B/M₁

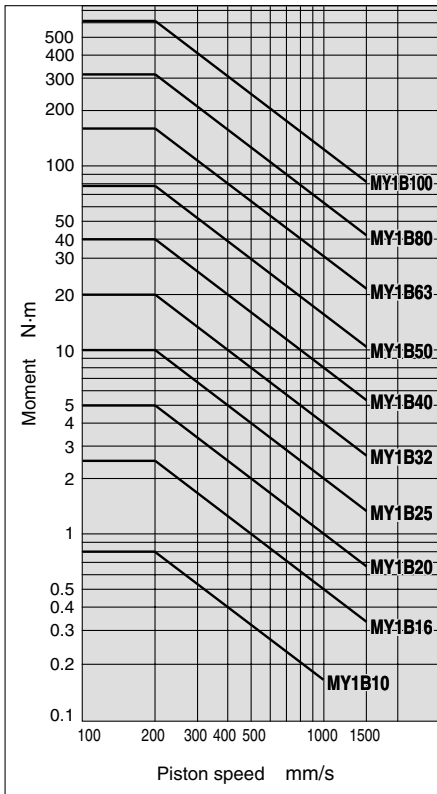

MY1B/M₂

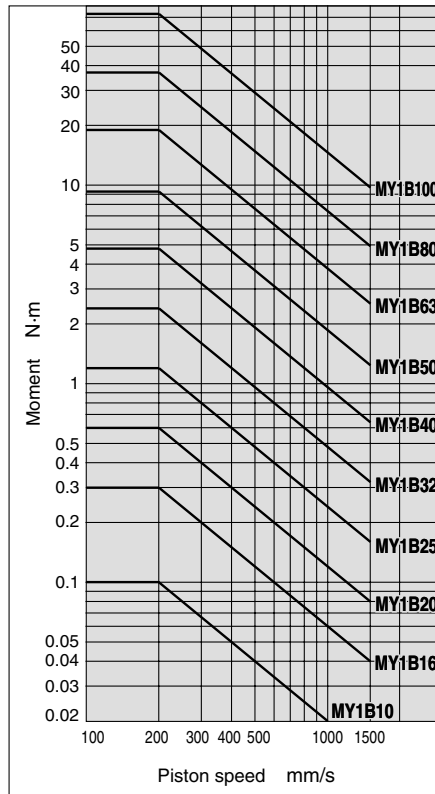

MY1B/M₃

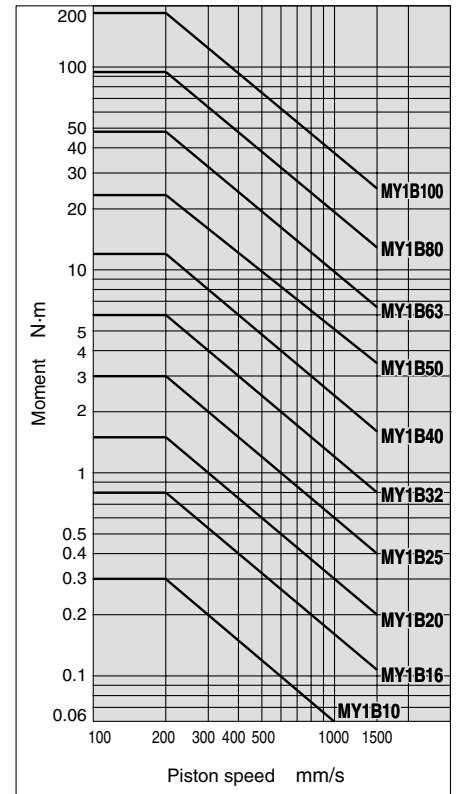

- MY1B**
- MY1M
- MY1C
- MY1H
- MY1HT
- MY1□W
- MY2C
- MY2H□
- MY3A
- MY3B
- MY3M

MY1B/m₁

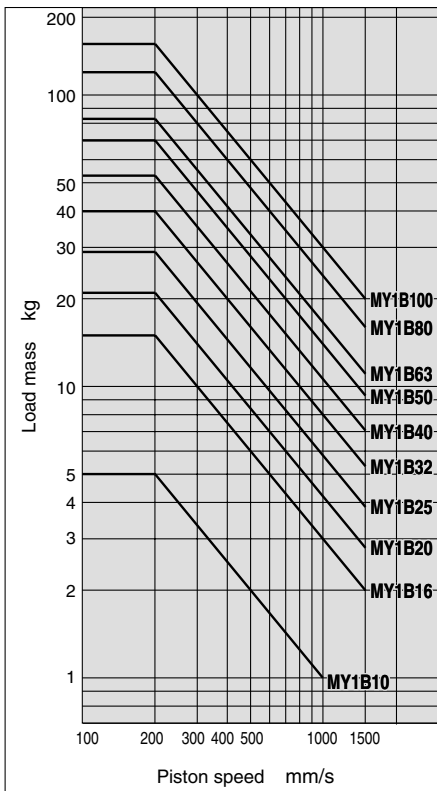

MY1B/m₂

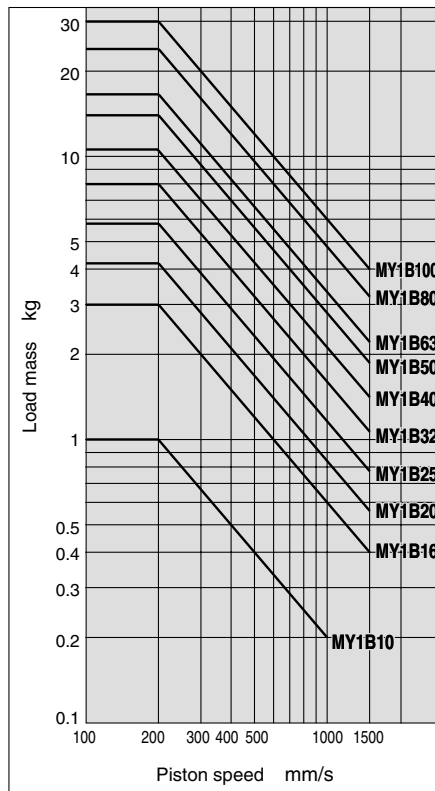

MY1B/m₃

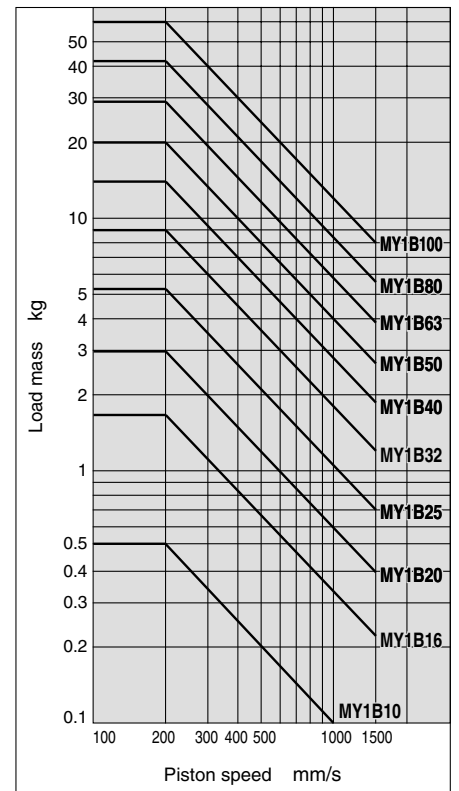

- D-□
- X□
- Individual
- X□
- Technical data

Series MY1B Model Selection

Following are the steps for selecting the most suitable Series MY1B to your application.

Calculation of Guide Load Factor

1. Operating Conditions

Cylinder MY1B32-500
 Average operating speed v_a 300 mm/s
 Mounting orientation Horizontal mounting
 Cushion Air cushion
 ($\delta = 1/100$)

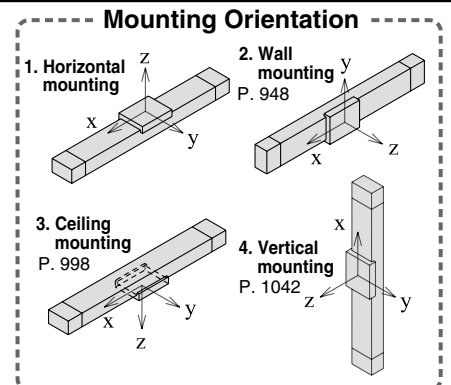
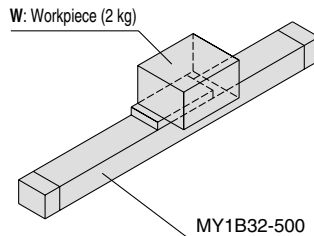

For actual examples of calculation for each orientation, refer to the pages above.

2. Load Blocking

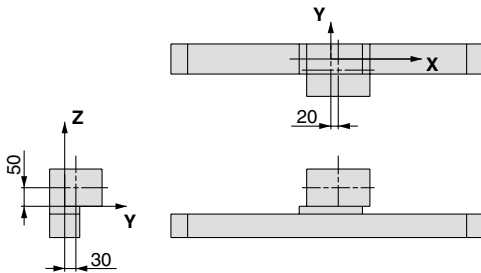

Mass and Center of Gravity for Workpiece

Workpiece no.	Mass m	Center of gravity		
		X-axis	Y-axis	Z-axis
W	2 kg	20 mm	30 mm	50 mm

3. Calculation of Load Factor for Static Load

m₁: Mass

m₁ max (from (1) of graph MY1B/**m₁**) = 27 (kg).....

Load factor $\alpha_1 = m_1/m_1 \text{ max} = 2/27 = 0.07$

M₁: Moment

M₁ max (from (2) of graph MY1B/**M₁**) = 13 (N·m).....

M₁ = **m₁** x **g** x **X** = 2 x 9.8 x 20 x 10⁻³ = 0.39 (N·m)

Load factor $\alpha_2 = M_1/M_1 \text{ max} = 0.39/13 = 0.03$

M₂: Moment

M₂ max (from (3) of graph MY1B/**M₂**) = 1.6 (N·m).....

M₂ = **m₁** x **g** x **Y** = 2 x 9.8 x 30 x 10⁻³ = 0.59 (N·m)

Load factor $\alpha_3 = M_2/M_2 \text{ max} = 0.59/1.6 = 0.37$

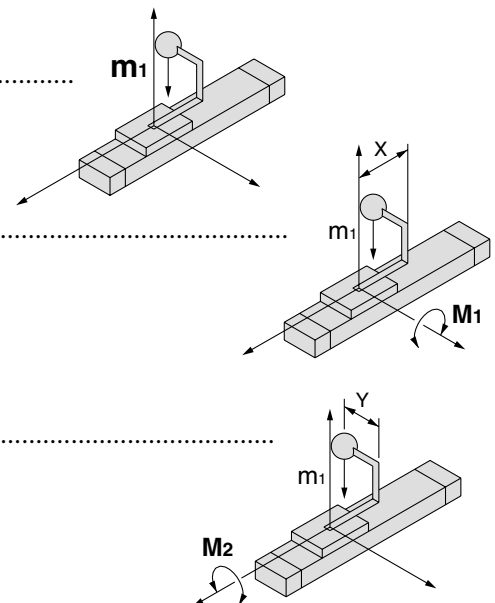

4. Calculation of Load Factor for Dynamic Moment

Equivalent load F_E at impact

$$F_E = 1.4U_a \times \delta \times m \times g = 1.4 \times 300 \times \frac{1}{100} \times 2 \times 9.8 = 82.3 \text{ (N)}$$

M_{1E} : Moment

$M_{1E} \text{ max}$ (from (1) of graph MY1B/ M_1 where $1.4U_a = 420 \text{ mm/s}$) = 9.5 (N·m).....

$$M_{1E} = \frac{1}{3} \times F_E \times Z = \frac{1}{3} \times 82.3 \times 50 \times 10^{-3} = 1.37 \text{ (N·m)}$$

$$\text{Load factor } \alpha_4 = M_{1E} / M_{1E} \text{ max} = 1.37 / 9.5 = 0.14$$

M_{3E} : Moment

$M_{3E} \text{ max}$ (from (5) of graph MY1B/ M_3 where $1.4U_a = 420 \text{ mm/s}$) = 2.9 (N·m).....

$$M_{3E} = \frac{1}{3} \times F_E \times Y = \frac{1}{3} \times 82.3 \times 30 \times 10^{-3} = 0.82 \text{ (N·m)}$$

$$\text{Load factor } \alpha_5 = M_{3E} / M_{3E} \text{ max} = 0.82 / 2.9 = 0.28$$

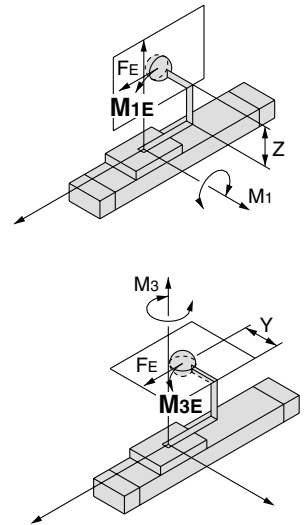

MY1B

MY1M

MY1C

MY1H

MY1HT

MY1□W

MY2C

MY2H□

MY3A

MY3B

MY3M

5. Sum and Examination of Guide Load Factors

$$\Sigma \alpha = \alpha_1 + \alpha_2 + \alpha_3 + \alpha_4 + \alpha_5 = 0.89 \leq 1$$

The above calculation is within the allowable value, and therefore the selected model can be used.

Select a shock absorber separately.

In an actual calculation, when the total sum of guide load factors $\Sigma \alpha$ in the formula above is more than 1, consider either decreasing the speed, increasing the bore size, or changing the product series. This calculation can be easily made using the "SMC Pneumatics CAD System".

Load Mass

MY1B/ m_1

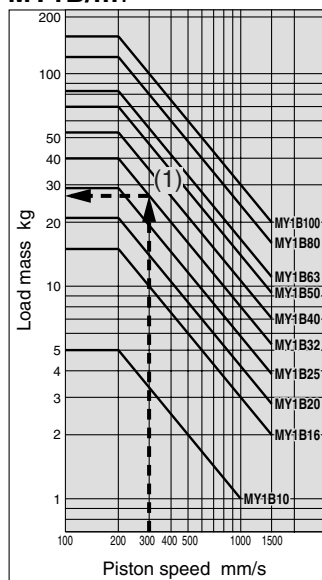

Allowable Moment

MY1B/ M_1

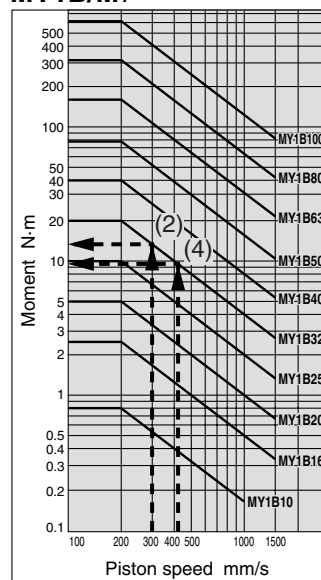

MY1B/ M_2

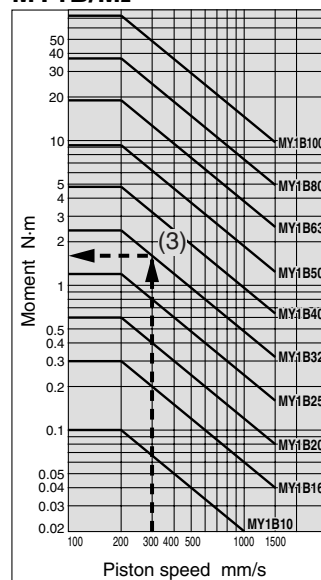

MY1B/ M_3

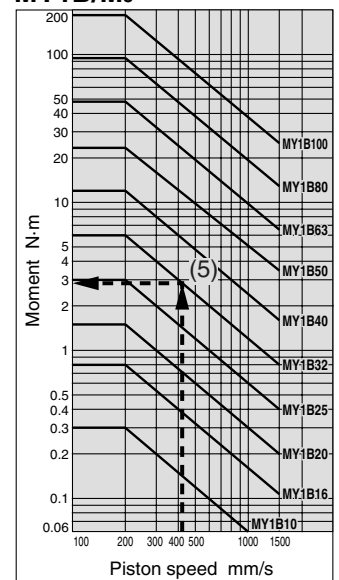

D-□

-X□

Individual

-X□

Technical data

Mechanically Jointed Rodless Cylinder Basic Type

Series MY1B

ø10, ø16, ø20, ø25, ø32, ø40, ø50, ø63, ø80, ø100

How to Order

Basic type MY1B 20 - 300 - M9BW

Bore size (mm)

10	10 mm
16	16 mm
20	20 mm
25	25 mm
32	32 mm
40	40 mm
50	50 mm
63	63 mm
80	80 mm
100	100 mm

Port thread type

Symbol	Type	Bore size
Nil	M thread	ø10, ø16, ø20
	Rc	ø25, ø32, ø40, ø50, ø63, ø80, ø100
TN	NPT	
TF	G	

Piping

Nil	Standard type
G	Centralized piping type

Note) For ø10, only G is available.

Cylinder stroke (mm)

Refer to "Standard Stroke" on page 957.

Stroke adjusting unit

Nil	Without adjusting unit
A	With adjusting bolt
L	With low load shock absorber + Adjusting bolt
H	With high load shock absorber + Adjusting bolt
AL	With one A unit and one L unit
AH	With one A unit and one H unit each
LH	With one L unit and one H unit each

Auto switch

Nil	Without auto switch (Built-in magnet)
-----	---------------------------------------

For ø10 cylinders without an auto switch, the cylinder configuration is for the reed auto switch. Contact SMC when the solid state auto switch is retrofitted.

Applicable auto switches vary depending on the bore size. Select an applicable one referring to the table below.

Number of auto switches

Nil	2 pcs.
S	1 pc.
n	"n" pcs.

Made to Order
Refer to page 957 for details.

Suffix for stroke adjusting unit

Nil	Both sides
S	One side

Note) "S" is applicable for stroke adjusting units A, L and H.

Shock Absorbers for L and H Units

Bore size (mm)	10	20	25	32	40
L unit	—	RB0806	RB1007	RB1412	
H unit	RB0805	RB1007	RB1412	RB2015	

The shock absorber service life is different from that of the MY1B cylinder depending on operating conditions. Refer to the RB Series Specific Product Precautions for the replacement period.

Applicable Auto Switch/Refer to pages 1263 to 1371 for further information on auto switches.

Type	Special function	Electrical entry	Indicator light	Wiring (Output)	Load voltage		Auto switch model			Lead wire length (m)				Pre-wired connector	Applicable load	
					DC	AC	Perpendicular		In-line		0.5 (Nil)	1 (M)	3 (L)			5 (Z)
							ø10 to ø20	ø25 to ø100	ø10 to ø20	ø25 to ø100						
Solid state switch	—	Grommet	Yes	3-wire (NPN)	5V, 12V	—	M9NV **	M9N **	●	●	○	○	IC circuit	Relay, PLC		
							[Y69A]	[Y59A]	●	●	○	○				
				3-wire (PNP)	12V	M9PV **	M9P **	●	●	○	○					
						[Y7PV]	[Y7P]	●	●	○	○					
				2-wire	12V	M9BV **	M9B **	●	●	○	○					
						[Y69B]	[Y59B]	●	●	○	○					
3-wire (NPN)	5V, 12V	M9NWV **	M9NW **	●	●	○	○									
		[Y7NWV]	[Y7NW]	●	●	○	○									
3-wire (PNP)	12V	M9PWV **	M9PW **	●	●	○	○									
		[Y7PWV]	[Y7PW]	●	●	○	○									
2-wire	12V	M9BWV **	M9BW **	●	●	○	○									
		[Y7BWV]	[Y7BW]	●	●	○	○									
Reed switch	—	Grommet	Yes	3-wire (NPN equivalent)	5V	—	A96V	A96	Z76	●	—	●	—	—	IC circuit	—
							—	—	—	●	—	●	—	—	—	—
				2-wire	24V	12V	—	—	Z73	●	—	●	●	—	—	—
100V or less	A90V	A90	Z80				●	—	●	—	—	—	—	—	IC circuit	

* Lead wire length symbols: 0.5 m Nil (Example) M9NW
 1 m M (Example) M9NWM
 3 m L (Example) M9NWL
 5 m Z (Example) M9NWX

* Solid state auto switches marked with "○" are produced upon receipt of order.
 ** D-M9□□□ type cannot be mounted on ø50.
 Select auto switches in brackets.

* There are other applicable auto switches than listed above. For details, refer to page 1053.
 * For details about auto switches with pre-wired connector, refer to pages 1328 and 1329.
 * Auto switches are shipped together (not assembled).

Mechanically Jointed Rodless Cylinder **Series MY1B**

Basic Type

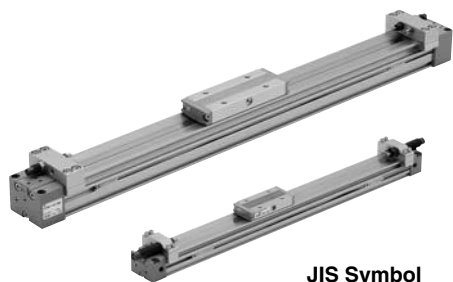

JIS Symbol

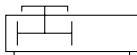

Specifications

Bore size (mm)	10	16	20	25	32	40	50	63	80	100	
Fluid	Air										
Action	Double acting										
Operating pressure range	0.2 to 0.8MPa		0.1 to 0.8 MPa								
Proof pressure	1.2 MPa										
Ambient and fluid temperature	5 to 60°C										
Cushion	Rubber bumper		Air cushion								
Lubrication	Non-lube										
Stroke length tolerance	1000 or less $^{+1.8}_0$ 1001 to 3000 $^{+2.8}_0$		2700 or less $^{+1.8}_0$, 2701 to 5000 $^{+2.8}_0$								
Piping Port size	Front/Side port	M5 x 0.8			Rc 1/8	Rc 1/4	Rc 3/8		Rc 1/2		
	Bottom port	/			ø4	ø5	ø6	ø8	ø10	ø11	ø16

Stroke Adjusting Unit Specifications

Bore size (mm)	10		16		20		25			32			40		
Unit symbol	A	H	A	A	L	H	A	L	H	A	L	H	A	L	H
Configuration Shock absorber model	With adjusting bolt	RB 0805 + with adjusting bolt	With adjusting bolt	With adjusting bolt	RB 0806 + with adjusting bolt	RB 1007 + with adjusting bolt	With adjusting bolt	RB 1007 + with adjusting bolt	RB 1412 + with adjusting bolt	With adjusting bolt	RB 1412 + with adjusting bolt	RB 2015 + with adjusting bolt	With adjusting bolt	RB 1412 + with adjusting bolt	RB 2015 + with adjusting bolt
Fine stroke adjustment range (mm)	0 to -5		0 to -5.6		0 to -6		0 to -11.5			0 to -12			0 to -16		
Stroke adjustment range	When exceeding the stroke fine adjustment range: Utilize a made-to-order specifications "-X416" and "-X417".														

* Stroke adjustment range is applicable for one side when mounted on a cylinder.

Shock Absorber Specifications

Model	RB 0805	RB 0806	RB 1007	RB 1412	RB 2015	
Max. energy absorption (J)	1.0	2.9	5.9	19.6	58.8	
Stroke absorption (mm)	5	6	7	12	15	
Max. collision speed (mm/s)	1000	1500	1500	1500	1500	
Max. operating frequency(cycle/min)	80	80	70	45	25	
Spring force (N)	Extended	1.96	1.96	4.22	6.86	8.34
	Retracted	3.83	4.22	6.86	15.98	20.50
Operating temperature range (°C)	5 to 60					

The shock absorber service life is different from that of the MY1B cylinder depending on operating conditions. Refer to the RB Series Specific Product Precautions for the replacement period.



Made to Order Specifications

(For details, refer to pages 1395 to 1565.)

Symbol	Specifications
-XB11	Long stroke type
-XC67	NBR rubber lining in dust seal band
-X168	Helical insert thread specifications
-X416	Holder mounting bracket I
-X417	Holder mounting bracket II

Standard Stroke

Bore size (mm)	Standard stroke (mm)*	Maximum manufacturable stroke (mm)
10, 16	100, 200, 300, 400, 500, 600, 700	3000
20, 25, 32, 40, 50, 63, 80, 100	800, 900, 1000, 1200, 1400, 1600, 1800, 2000	5000

* Strokes are manufacturable in 1 mm increments, up to the maximum stroke. However, when exceeding a 2000 mm stroke, specify "-XB11" at the end of the model number.

Piston Speed

Bore size (mm)	10	16 to 100
Without stroke adjusting unit	100 to 500 mm/s	100 to 1000 mm/s
Stroke adjusting unit	A unit	100 to 200 mm/s
	L unit and H unit	100 to 1000 mm/s

Note 1) Be aware that when the stroke adjusting range is increased by manipulating the adjusting bolt, the air cushion capacity decreases. Also, when exceeding the air cushion stroke ranges on page 960, **the piston speed should be 100 to 200 mm per second.**

Note 2) The piston speed is 100 to 1000 mm/s for centralized piping.

Note 3) Use at a speed within the absorption capacity range. Refer to page 959.

MY1B

MY1M

MY1C

MY1H

MY1HT

MY1□W

MY2C

MY2H□

MY3A

MY3B

MY3M

D-□

-X□

Individual -X□

Technical data

Series MY1B

Theoretical Output

Bore size (mm)	Piston area (mm ²)	Operating pressure (MPa)						
		0.2	0.3	0.4	0.5	0.6	0.7	0.8
10	78	15	23	31	39	46	54	62
16	200	40	60	80	100	120	140	160
20	314	62	94	125	157	188	219	251
25	490	98	147	196	245	294	343	392
32	804	161	241	322	402	483	563	643
40	1256	251	377	502	628	754	879	1005
50	1962	392	588	784	981	1177	1373	1569
63	3115	623	934	1246	1557	1869	2180	2492
80	5024	1004	1507	2009	2512	3014	3516	4019
100	7850	1570	2355	3140	3925	4710	5495	6280

Note) Theoretical output (N) = Pressure (MPa) x Piston area (mm²)

Mass

Bore size (mm)	Basic mass	Additional mass per each 50mm of stroke	Side support mass (per set)	Stroke adjusting unit mass (per unit)		
			Type A and B	A unit mass	L unit mass	H unit mass
10	0.15	0.04	0.003	0.01	—	0.02
16	0.61	0.06	0.01	0.04	—	—
20	1.06	0.10	0.02	0.05	0.05	0.10
25	1.33	0.12	0.02	0.06	0.10	0.18
32	2.65	0.18	0.02	0.12	0.21	0.40
40	3.87	0.27	0.04	0.23	0.32	0.49
50	7.78	0.44	0.04	—	—	—
63	13.10	0.70	0.08	—	—	—
80	20.70	1.18	0.17	—	—	—
100	35.70	1.97	0.17	—	—	—

Calculation: (Example) MY1B25-300A
 • Basic mass1.33 kg
 • Cylinder stroke300 stroke
 • Additional mass0.12/50 stroke
 $1.33 + 0.12 \times 300/50 + 0.06 \times 2 \approx 2.17$ kg
 • Mass of A unit0.06 kg

Option

Stroke Adjusting Unit Part No.

Bore size (mm)		10	16	20	25	32	40
A unit	Left	MY-A10A1	MY-A16A1	MY-A20A1	MY-A25A1	MY-A32A1	MY-A40A1
	Right	MY-A10A2	MY-A16A2	MY-A20A2	MY-A25A2	MY-A32A2	MY-A40A2
L unit	Left	—	—	MY-A20L1	MY-A25L1	MY-A32L1	MY-A40L1
	Right	—	—	MY-A20L2	MY-A25L2	MY-A32L2	MY-A40L2
H unit	Left	MY-A10H1	—	MY-A20H1	MY-A25H1	MY-A32H1	MY-A40H1
	Right	MY-A10H2	—	MY-A20H2	MY-A25H2	MY-A32H2	MY-A40H2

Stroke adjusting unit form and mounting direction

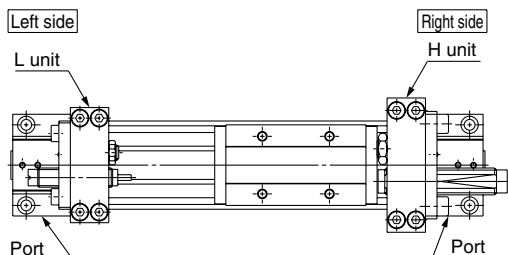

Stroke adjusting unit
Example of LH attachment

Side Support Part No.

Bore size (mm)		10	16	20	25	32	40	50	63	80	100
Side support A	Type	MY-S10A	MY-S16A	MY-S20A	MY-S25A	MY-S32A	MY-S32A	MY-S50A	MY-S50A	MY-S63A	MY-S63A
Side support B	Type	MY-S10B	MY-S16B	MY-S20B	MY-S25B	MY-S32B	MY-S32B	MY-S50B	MY-S50B	MY-S63B	MY-S63B

For details about dimensions, etc., refer to page 971.
 A set of side supports consists of a left support and a right support.

Cushion Capacity

Cushion Selection

<Rubber bumper>

Rubber bumpers are a standard feature on MY1B10.

Since the stroke absorption of rubber bumpers is short, when adjusting the stroke with an A unit, install an external shock absorber.

The load and speed range which can be absorbed by a rubber bumper is inside the rubber bumper limit line of the graph.

<Air cushion>

Air cushions are a standard feature on mechanically jointed rodless cylinders. (Except $\phi 10$.)

The air cushion mechanism is incorporated to prevent excessive impact of the piston at the stroke end during high speed operation. The purpose of air cushion, thus, is not to decelerate the piston near the stroke end.

The ranges of load and speed that air cushions can absorb are within the air cushion limit lines shown in the graphs.

<Stroke adjusting unit with shock absorber>

Use this unit when operating with a load or speed exceeding the air cushion limit line, or when cushioning is required outside of the effective air cushion stroke range due to stroke adjustment.

L unit

Use this unit when cushioning is necessary outside of the effective air cushion range even if the load and speed are within the air cushion limit line, or when the cylinder is operated in a load and speed range above the air cushion limit line and below the L unit limit line.

H unit

Use this unit when the cylinder is operated in a load and speed range above the L unit limit line and below the H unit limit line.

⚠ Caution

1. Refer to the figure below when using the adjusting bolt to perform stroke adjustment.

When the effective stroke of the shock absorber decreases as a result of stroke adjustment, the absorption capacity decreases dramatically. Secure the adjusting bolt at the position where it protrudes approximately 0.5 mm from the shock absorber.

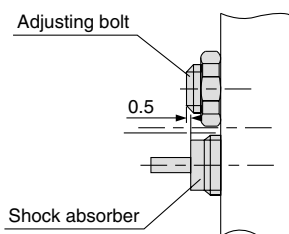

2. Do not use a shock absorber together with air cushion.

Absorption Capacity of Rubber Bumper, Air Cushion and Stroke Adjusting Units

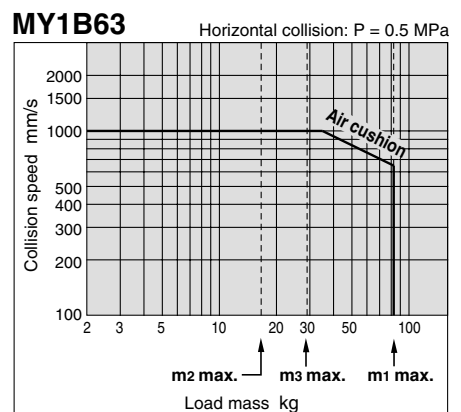
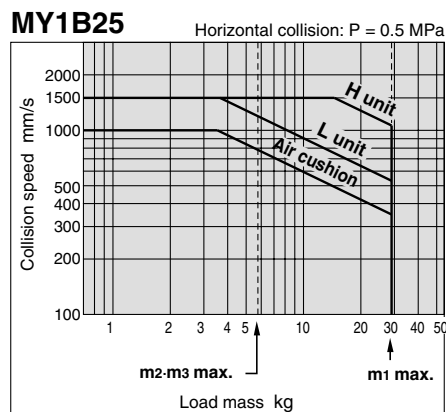
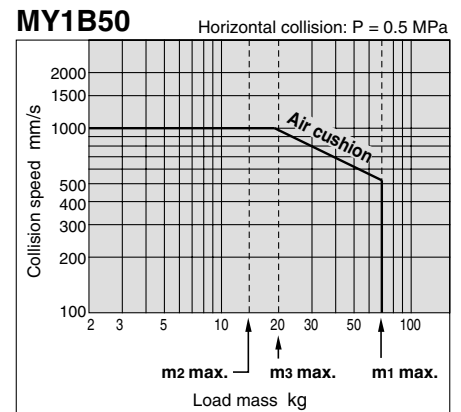
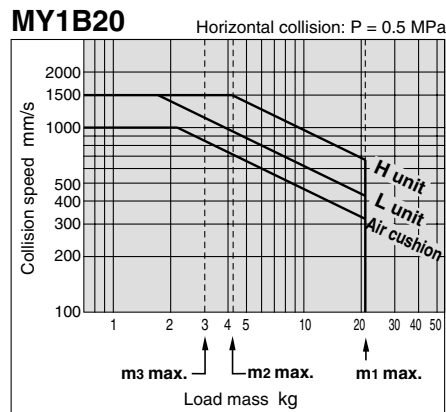
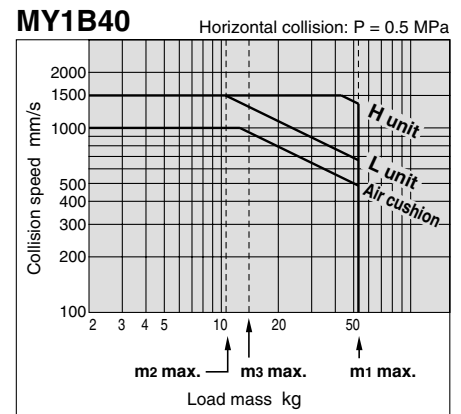
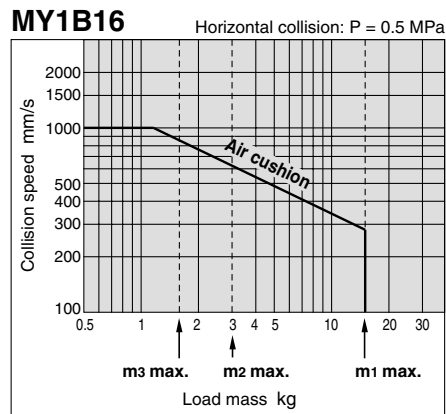
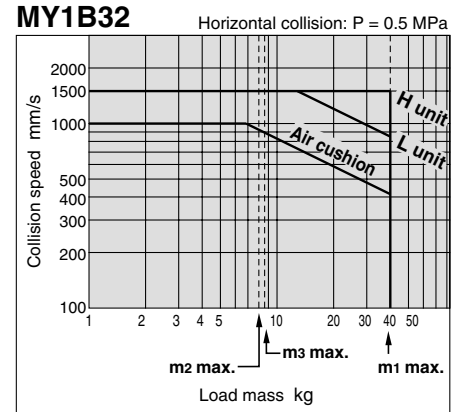
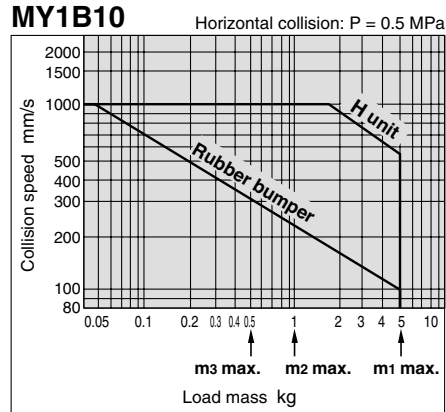

MY1B

MY1M

MY1C

MY1H

MY1HT

MY1□W

MY2C

MY2H□

MY3A

MY3B

MY3M

D-□

-X□

Individual

-X□

Technical data

Series MY1B

Cushion Capacity

Rubber Bumper/Air Cushion Stroke Adjustment Unit Absorption Capacity

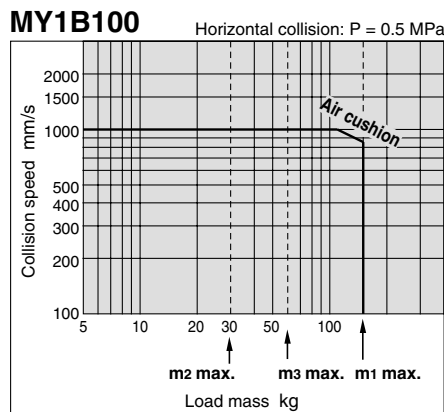
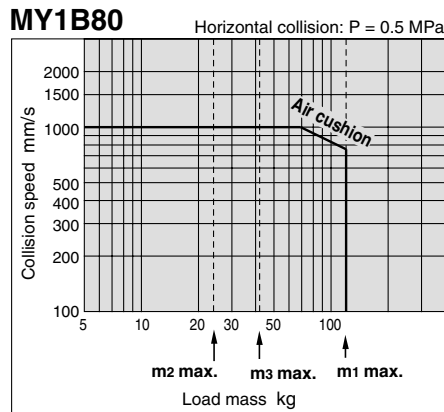

Air Cushion Stroke (mm)

Bore size (mm)	Cushion stroke
16	12
20	15
25	15
32	19
40	24
50	30
63	37
80	40
100	40

Rubber Bumper (ø10 only) Positive Stroke from One End Due to Pressure

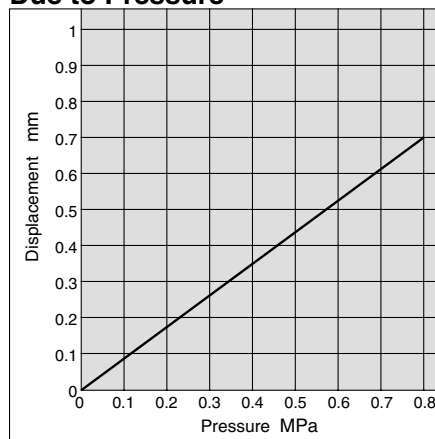

Tightening Torque for Stroke Adjusting Unit Holding Bolts (N·m)

Bore size (mm)	Unit	Tightening torque
10	A	0.4
	H	
16	A	0.7
	H	
20	A	1.8
	L	
	H	
	A	
25	A	3.5
	L	
	H	
	A	
32	A	5.8
	L	
	H	
	A	
40	A	13.8
	L	
	H	
	A	

Tightening Torque for Stroke Adjusting Unit Lock Plate Holding Bolts (N·m)

Bore size (mm)	Unit	Tightening torque
20	H	1.2
	L	
25	H	3.3
	L	
32	L	3.3
	H	
40	L	3.3
	H	

Calculation of Absorbed Energy for Stroke Adjusting Unit with Shock Absorber (N·m)

Type of impact	Horizontal collision	Vertical (Downward)	Vertical (Upward)
Kinetic energy E ₁		$\frac{1}{2} m \cdot v^2$	
Thrust energy E ₂	F·s	Fs + m·g·s	Fs - m·g·s
Absorbed energy E	E ₁ + E ₂		

Symbol

v: Speed of impact object (m/s)

F: Cylinder thrust (N)

s: Shock absorber stroke (m)

m: Mass of impact object (kg)

g: Gravitational acceleration (9.8 m/s²)

Note) The speed of the impact object is measured at the time of impact with the shock absorber.

⚠ Precautions

Be sure to read before handling. Refer to front matters 54 and 55 for Safety Instructions and pages 3 to 11 for Actuator and Auto Switch Precautions.

⚠ Caution

Use caution not to get your hands caught in the unit.

- When using a product with stroke adjusting unit, the space between the slide table (slider) and the stroke adjusting unit becomes narrow at the stroke end, causing a danger of hands getting caught. Install a protective cover to prevent direct contact with the human body.

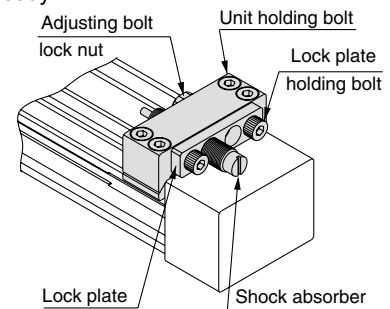

<Fastening of unit>

The unit can be secured by evenly tightening the four unit holding bolts.

⚠ Caution

Do not operate with the stroke adjusting unit fixed in an intermediate position.

When the stroke adjusting unit is fixed in an intermediate position, slippage can occur depending on the amount of energy released at the time of an impact. In such cases, the use of the adjusting bolt mounting brackets, available per made-to-order specifications -X416 and -X417, is recommended. (Except ø10)

For other lengths, please consult with SMC (Refer to "Tightening Torque for Stroke Adjusting Unit Holding Bolts".)

<Stroke adjustment with adjusting bolt>
Loosen the adjusting bolt lock nut, and adjust the stroke from the lock plate side using a hexagon wrench. Retighten the lock nut.

<Stroke adjustment with shock absorber>

Loosen the two lock plate holding bolts, turn the shock absorber and adjust the stroke. Then, uniformly tighten the lock plate holding bolts to secure the shock absorber.

Take care not to over-tighten the holding bolts. (Except ø10 and ø20 L unit.) (Refer to "Tightening Torque for Stroke Adjusting Unit Lock Plate Holding Bolts".)

Note)

Although the lock plate may slightly bend due to tightening of the lock plate holding bolt, this does not affect the shock absorber and locking function.

Construction: $\phi 10$

Centralized piping type: MY1B10G

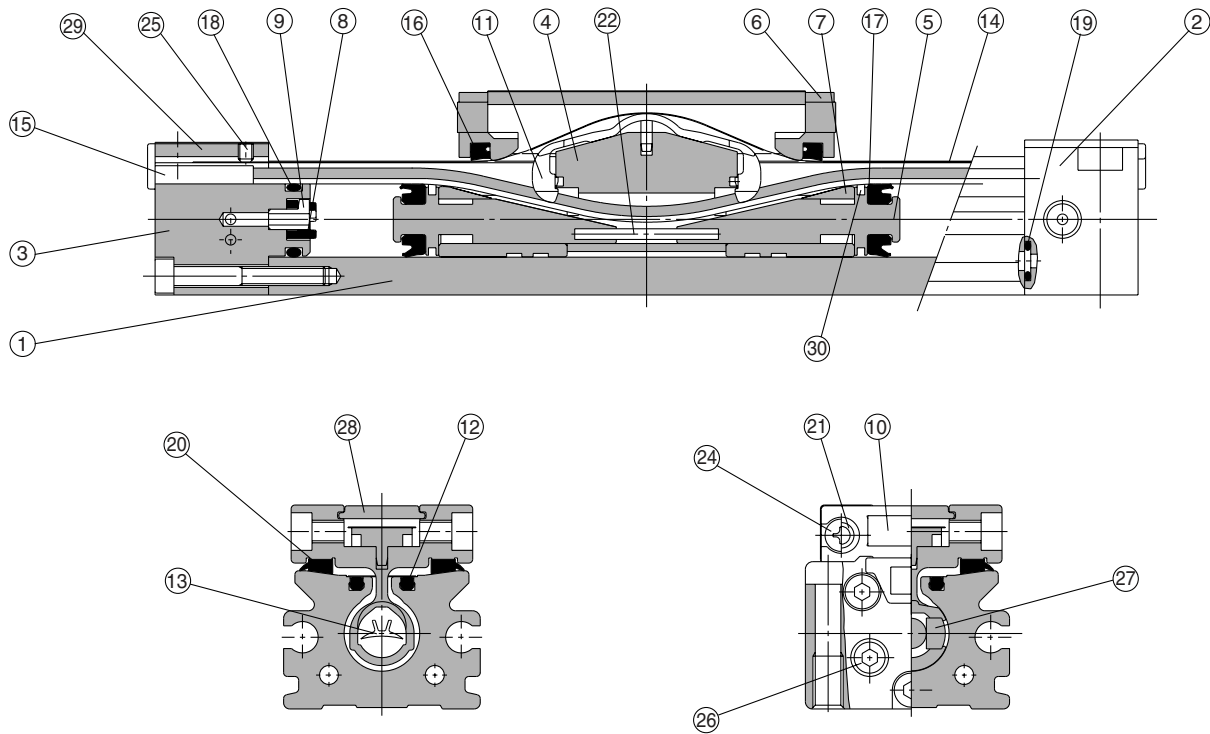

- MY1B
- MY1M
- MY1C
- MY1H
- MY1HT
- MY1□W
- MY2C
- MY2H□
- MY3A
- MY3B
- MY3M

Component Parts

No.	Description	Material	Note
1	Cylinder tube	Aluminum alloy	Hard anodized
2	Head cover WR	Aluminum alloy	Painted
3	Head cover WL	Aluminum alloy	Painted
4	Piston yoke	Aluminum alloy	Hard anodized
5	Piston	Aluminum alloy	Chromated
6	End Cover	Special resin	
7	Wear ring	Special resin	
8	Bumper	Polyurethane rubber	
9	Holder	Stainless steel	
10	Stopper	Carbon steel	Nickel plated
11	Belt separator	Special resin	
12	Seal magnet	Rubber magnet	

No.	Description	Material	Note
15	Belt clamp	Special resin	
20	Bearing	Special resin	
21	Spacer	Chromium molybdenum steel	Nickel plated
22	Spring pin	Stainless steel	
23	Hexagon socket head cap screw	Chromium molybdenum steel	Nickel plated
24	Round binding head crew	Carbon steel	Nickel plated
25	Slotted set screw	Carbon steel	Black zinc chromated
26	Hexagon socket head plug	Carbon steel	Nickel plated
27	Magnet	—	
28	Top plate	Stainless steel	
29	Head plate	Stainless steel	
30	Felt	Felt	

Replacement Part: Seal Kit

No.	Description	Qty.	MY1B10
13	Seal belt	1	MY10-16A-Stroke
14	Dust seal band	1	MY10-16B-Stroke
16	Scraper	2	MY1B10-PS
17	Piston seal	2	
18	Tube gasket	2	
19	O-ring	4	

* Seal kit includes 16, 17, 18 and 19.
 Seal kit includes a grease pack (10 g).
 When 13 and 14 are shipped independently, a grease pack is included. (10 g per 1000 strokes)
 Order with the following part number when only the grease pack is needed.
Grease pack part number: GR-S-010 (10 g), GR-S-020 (20 g)

- D-□
- X□
- Individual -X□
- Technical data

Series MY1B

Construction: $\varnothing 16$ to $\varnothing 100$

MY1B16 to 100

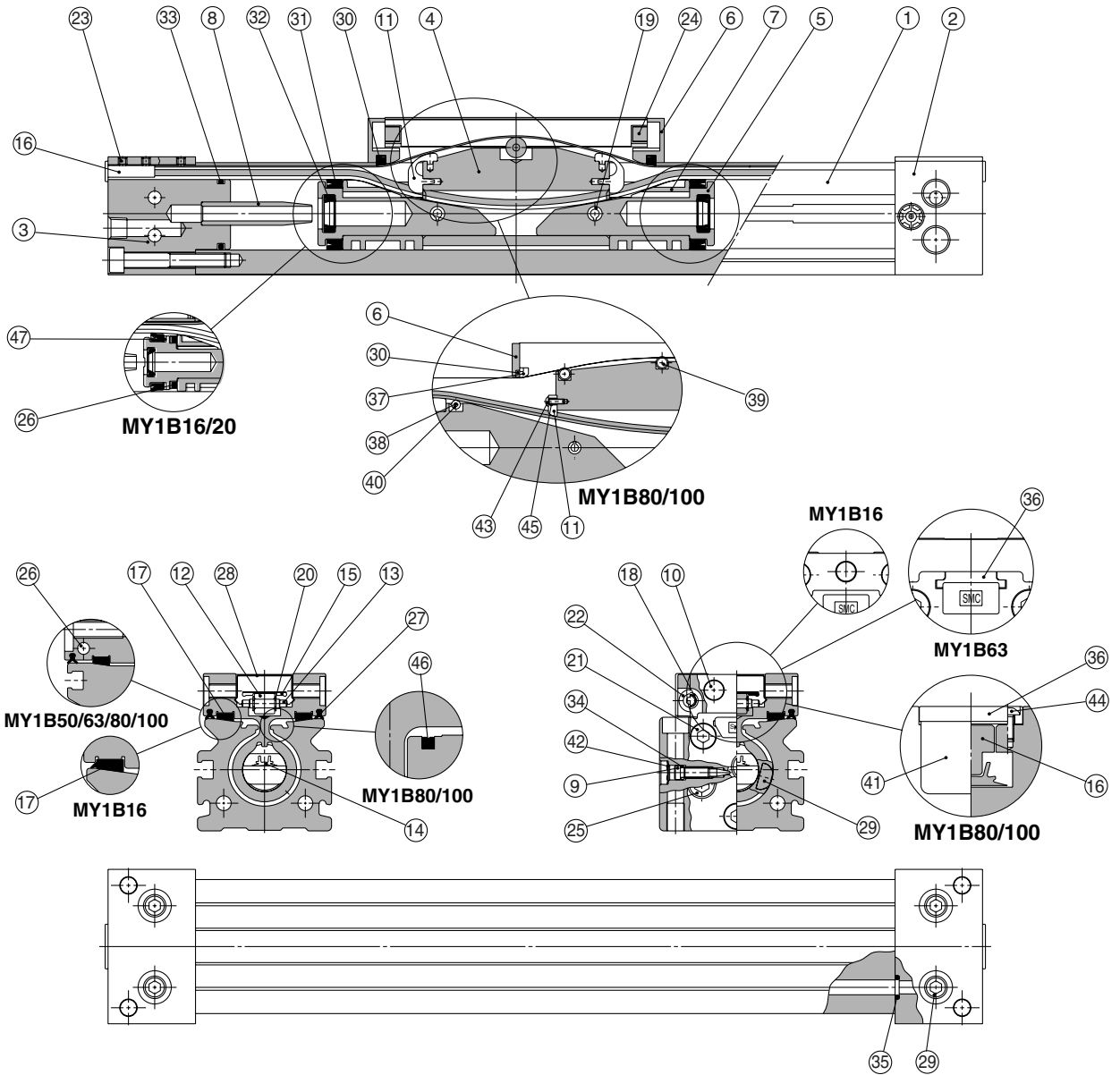

MY1B16 to 100

Component Parts

No.	Description	Material	Note
1	Cylinder tube	Aluminum alloy	Hard anodized
2	Head cover WR	Aluminum alloy	Painted
3	Head cover WL	Aluminum alloy	Painted
4	Piston yoke	Aluminum alloy	Anodized
5	Piston	Aluminum alloy	Chromated
6	End cover	Special resin	
		Carbon steel	Nickel plated (ø80, ø100)
7	Wear ring	Special resin	
8	Cushion ring	Brass	
9	Cushion needle	Rolled steel	Nickel plated
10	Stopper	Carbon steel	Nickel plated
11	Belt separator	Special resin	
12	Guide roller	Special resin	(ø16 to ø63)
13	Guide roller shaft	Stainless steel	(ø16 to ø63)
16	Belt clamp	Special resin	
		Aluminum alloy	Chromated (ø80, ø100)
17	Bearing	Special resin	
18	Spacer	Stainless steel	(ø16 to ø63)
19	Spring pin	Carbon tool steel	Black zinc chromated
20	Type E retaining ring	Cold rolled special steel strip	(ø25 to ø63)
21	Hexagon socket head cap screw	Chromium molybdenum steel	Nickel plated
22	Hexagon socket button head screw	Chromium molybdenum steel	Nickel plated
23	Hexagon socket head set screw	Chromium molybdenum steel	Black zinc chromated/ Nickel plated
24	Double round parallel key	Carbon steel	(ø16 to ø40)
25	Hexagon socket head taper plug	Carbon steel	Nickel plated

No.	Description	Material	Note
26	Magnet	—	
28	Top cover	Stainless steel	
29	Hexagon socket head taper plug	Carbon steel	Nickel plated
36	Head plate	Aluminum alloy	Painted (ø63 to ø100)
37	Backup plate	Special resin	(ø80, ø100)
38	Guide roller B	Special resin	(ø80, ø100)
39	Guide roller A	Stainless steel	(ø80, ø100)
40	Guide roller shaft B	Stainless steel	(ø80, ø100)
41	Side cover	Aluminum alloy	Hard anodized (ø80, ø100)
42	Type CR retaining ring	Spring steel	
43	Hexagon socket button head screw	Chromium molybdenum steel	Nickel plated (ø80, ø100)
44	Hexagon socket button head screw	Chromium molybdenum steel	Nickel plated (ø80, ø100)
45	Spacer B	Stainless steel	(ø80, ø100)
46	Seal magnet	Rubber magnet	(ø80, ø100)
47	Lube retainer	Special resin	(ø16, ø20)

MY1B

MY1M

MY1C

MY1H

MY1HT

MY1□W

MY2C

MY2H□

MY3A

MY3B

MY3M

Replacement Part: Seal Kit

No.	Description	Qty.	MY1B16	MY1B20	MY1B25	MY1B32	MY1B40
14	Seal belt	1	MY16-16A-Stroke	MY20-16A-Stroke	MY25-16A-Stroke	MY32-16A-Stroke	MY40-16A-Stroke
15	Dust seal band	1	MY16-16B-Stroke	MY20-16B-Stroke	MY25-16B-Stroke	MY32-16B-Stroke	MY40-16B-Stroke
27	Side scraper	2		MYB20-15CA7164B	MYB25-15BA5900B	MYB32-15BA5901B	MYB40-15BA5902B
34	O-ring	2	ø4 x ø1.8 x ø1.1	ø4 x ø1.8 x ø1.1	ø5.1 x ø3 x ø1.05	ø7.15 x ø3.75 x ø1.7	ø7.15 x ø3.75 x ø1.7
30	Scrape	2					
31	Piston seal	2					
32	Cushion seal	2	MY1B16-PS	MY1B20-PS	MY1B25-PS	MY1B32-PS	MY1B40-PS
33	Tube gasket	2					
35	O-ring	4					

No.	Description	Qty.	MY1B50	MY1B63	MY1B80	MY1B100
14	Seal belt	1	MY50-16A-Stroke	MY63-16A-Stroke	MY80-16A-Stroke	MY100-16A-Stroke
15	Dust seal band	1	MY50-16B-Stroke	MY63-16B-Stroke	MY80-16B-Stroke	MY100-16B-Stroke
27	Side scraper	2	MYB50-15CA7165B	MYB63-15CA7166B	MYB80-15CK2470B	MY100-15CK2471B
34	O-ring	2	ø8.3 x ø4.5 x ø1.9	C4	C6	C6
30	Scrape	2				
31	Piston seal	2				
32	Cushion seal	2	MY1B50-PS	MY1B63-PS	MY1B80-PS	MY1B100-PS
33	Tube gasket	2				
35	O-ring	4				

* Seal kit includes ⑩, ⑪, ⑫, ⑬ and ⑭. Order the seal kit based on each bore size.

* Seal kit includes a grease pack (10 g).

When ⑭ and ⑮ are shipped independently, a grease pack is included. (10 g per 1000 strokes)

Order with the following part number when only the grease pack is needed.

Grease pack part number: GR-S-010 (10 g), GR-S-020 (20 g)

Note) Two kinds of dust seal bands are available. Verify the type to use, since the part number varies depending on the treatment of the hexagon socket head set screw ⑮.

A: Black zinc chromated → MY□□-16B-stroke, B: Nickel plated → MY□□-16BW-stroke

D-□

-X□

Individual
-X□

Technical
data

Series MY1B

Centralized Piping Type $\phi 10$

Refer to page 1056 regarding centralized piping port variations.

MY1B10G — Stroke

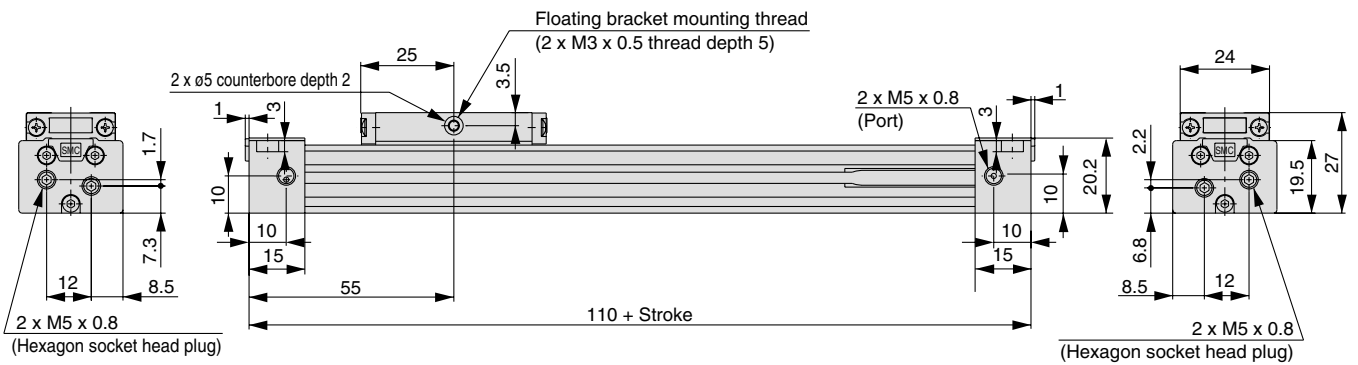
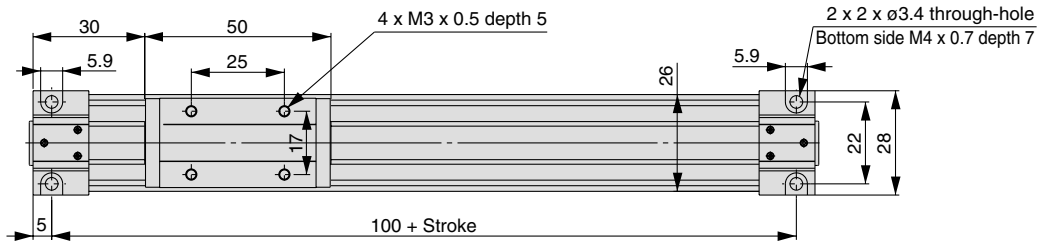
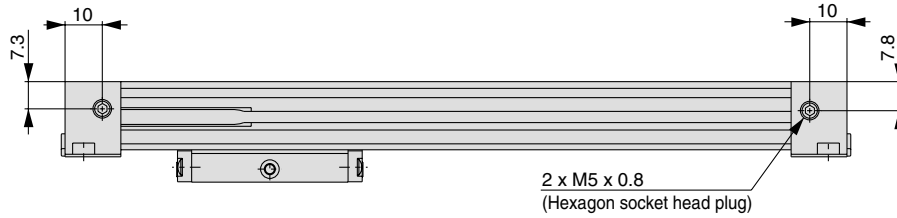

Mechanically Jointed Rodless Cylinder **Series MY1B**

Standard Type/Centralized Piping Type $\phi 16, \phi 20$

Refer to page 1056 regarding centralized piping port variations.

MY1B16□/20□ — Stroke

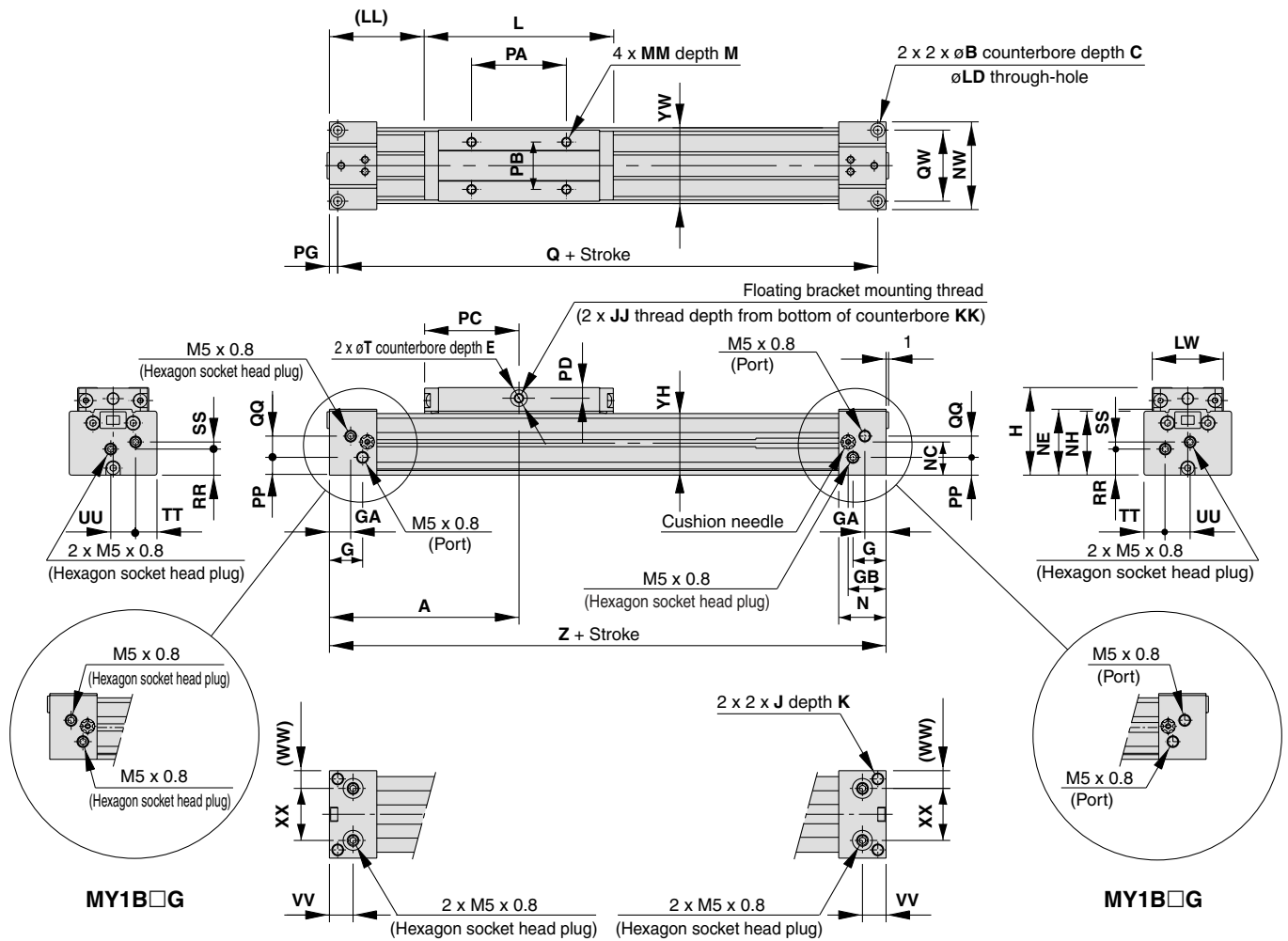

MY1B

MY1M

MY1C

MY1H

MY1HT

MY1□W

MY2C

MY2H□

MY3A

MY3B

MY3M

Model	A	B	C	E	G	GA	GB	H	J	JJ	K	KK	L	LD	LL	LW	M	MM	N	NC	NE
MY1B16□	80	6	3.5	2	14	9	16	37	M5 x 0.8	M4 x 0.7	10	6.5	80	3.5	40	30	6	M4 x 0.7	20	14	27.8
MY1B20□	100	7.5	4.5	2	12.5	12.5	17.5	46	M6 x 1	M4 x 0.7	12	10	100	4.5	50	37	8	M5 x 0.8	25	17.5	34

Model	NH	NW	PA	PB	PC	PD	PG	PP	Q	QQ	QW	RR	SS	T	TT	UU	VV	WW	XX	YH	YW	Z
MY1B16□	27	37	40	20	40	4.5	3.5	7.5	153	9	30	11	3	7	9	10.5	10	7.5	22	26	32	160
MY1B20□	33.5	45	50	25	50	5	4.5	11.5	191	11	36	14.5	5	8	10.5	12	12.5	10.5	24	32.5	40	200

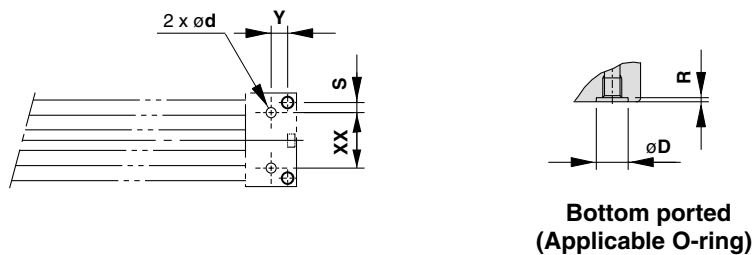

Hole Size for Centralized Piping on the Bottom

Model	WX	Y	S	d	D	R	Applicable O-ring
MY1B16□	22	6.5	4	4	8.4	1.1	C6
MY1B20□	24	8	6	4	8.4	1.1	

(Machine the mounting side to the dimensions below.)

D-□

-X□

Individual

-X□

Technical

data

Series MY1B

Standard Type/Centralized Piping Type $\phi 25, \phi 32, \phi 40$ Refer to page 1056 regarding centralized piping port variations.

MY1B25□/32□/40□ — Stroke

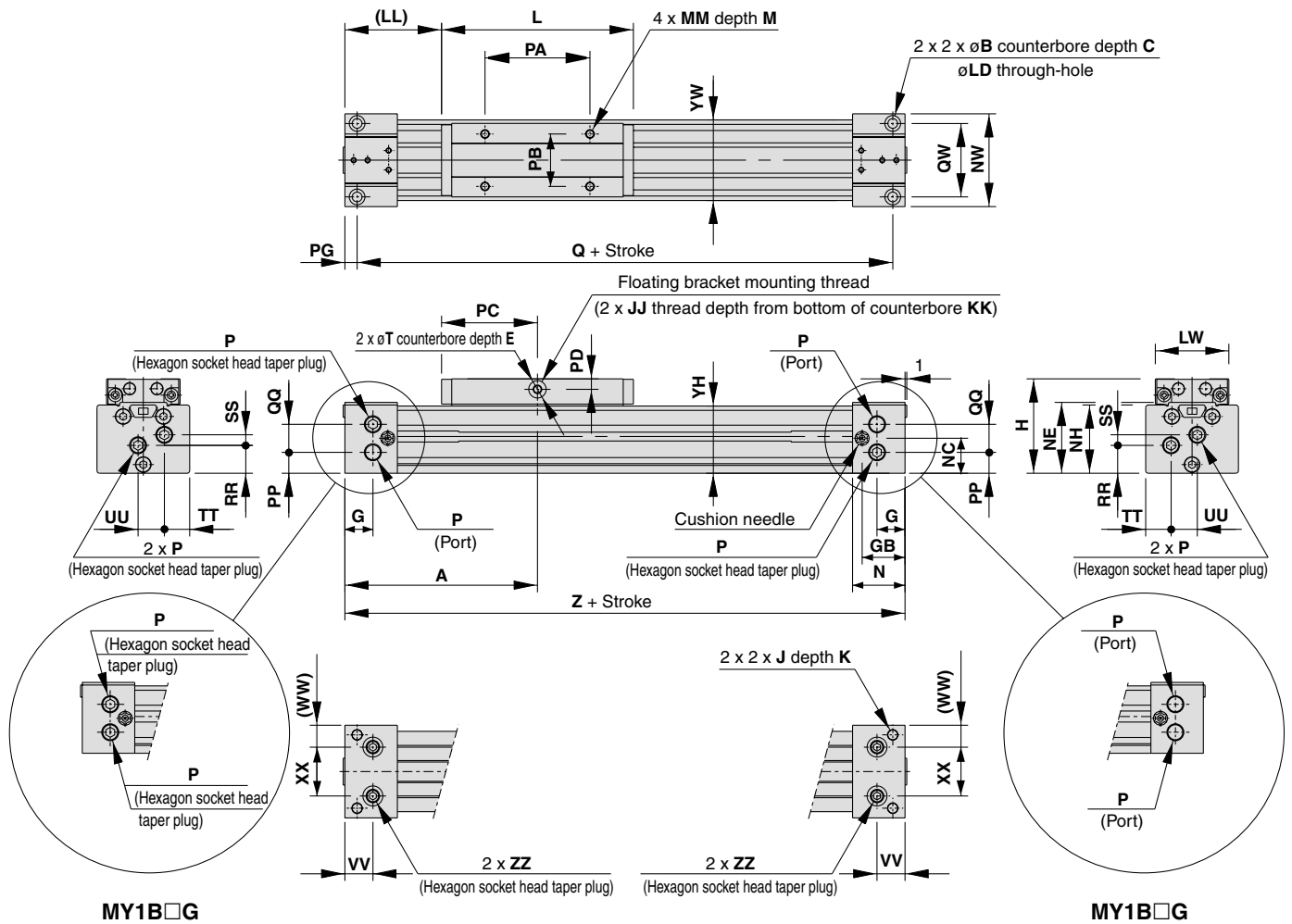

Model	A	B	C	E	G	GB	H	J	JJ	K	KK	L	LD	LL	LW	M	MM	N	NC	NE	NH	NW
MY1B25□	110	9	5.5	2	16	24.5	54	M6 x 1	M5 x 0.8	9.5	9	110	5.6	55	42	9	M5 x 0.8	30	20	40.5	39	53
MY1B32□	140	11	6.6	2	19	30	68	M8 x 1.25	M5 x 0.8	16	10	140	6.8	70	52	12	M6 x 1	37	25	50	49	64
MY1B40□	170	14	8.5	2	23	36.5	84	M10 x 1.5	M6 x 1	15	13	170	8.6	85	64	12	M6 x 1	45	30.5	63	61.5	75

Model	P	PA	PB	PC	PD	PP	PG	Q	QQ	QW	RR	SS	T	TT	UU	VV	WW	XX	YH	YW	Z	ZZ
MY1B25□	Rc 1/8	60	30	55	6	12	7	206	16	42	16	6	10	14.5	15	16	12.5	28	38.5	46	220	Rc 1/16
MY1B32□	Rc 1/8	80	35	70	10	17	8	264	16	51	23	4	10	16	16	19	16	32	48	55	280	Rc 1/16
MY1B40□	Rc 1/4	100	40	85	12	18.5	9	322	24	59	27	10.5	14	20	22	23	19.5	36	60.5	67	340	Rc 1/8

"P" indicates cylinder supply ports.

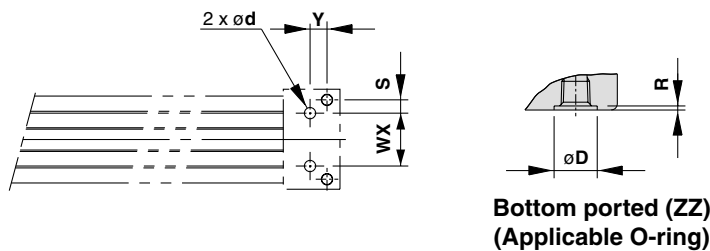

Hole Size for Centralized Piping on the Bottom

Model	WX	Y	S	d	D	R	Applicable O-ring
MY1B25□	28	9	7	6	11.4	1.1	C9
MY1B32□	32	11	9.5	6	11.4	1.1	
MY1B40□	36	14	11.5	8	13.4	1.1	C11.2

(Machine the mounting side to the dimensions below.)

Mechanically Jointed Rodless Cylinder Basic Type **Series MY1B**

Standard Type/Centralized Piping Type $\phi 50, \phi 63$

Refer to page 1056 regarding centralized piping port variations.

MY1B50□/63□ — **Stroke**

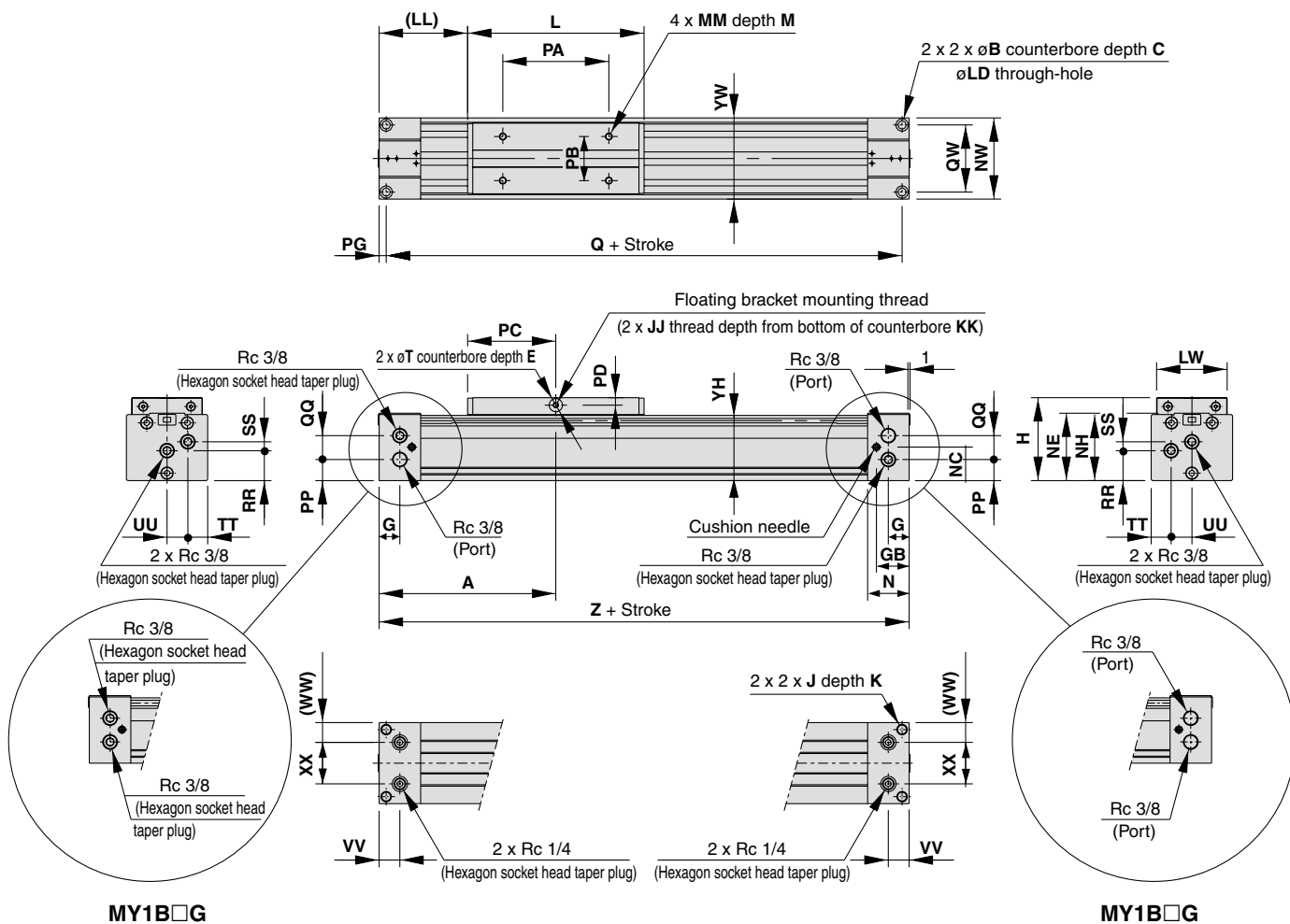

- MY1B
- MY1M
- MY1C
- MY1H
- MY1HT
- MY1□W
- MY2C
- MY2H□
- MY3A
- MY3B
- MY3M

Model	A	B	C	E	G	GB	H	J	JJ	K	KK	L	LD	LL	LW	M	MM	N	NC	NE
MY1B50□	200	14	8.5	3	23.5	37	94	M12 x 1.75	M6 x 1	25	17	200	9	100	80	14	M8 x 1.25	47	38	76.5
MY1B63□	230	17	10.5	3	25	39	116	M14 x 2	M8 x 1.25	28	24	230	11	115	96	16	M8 x 1.25	50	51	100

Model	NH	NW	PA	PB	PC	PD	PG	PP	Q	QQ	QW	RR	SS	T	TT	UU	VV	WW	XX	YH	YW	Z
MY1B50□	75	92	120	50	100	8.5	8	24	384	27	76	34	10	15	22.5	23.5	23.5	22.5	47	74	92	400
MY1B63□	95	112	140	60	115	9.5	10	37.5	440	29.5	92	45.5	13.5	16	27	29	25	28	56	94	112	460

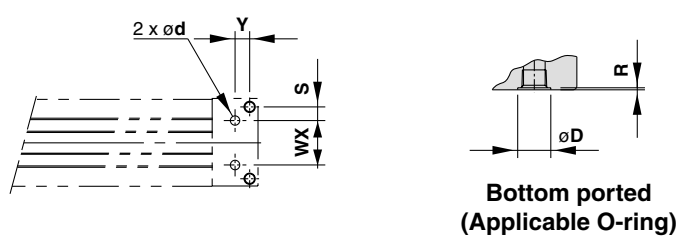

Hole Size for Centralized Piping on the Bottom

Model	WX	Y	S	d	D	R	Applicable O-ring
MY1B50□	47	15.5	14.5	10	17.5	1.1	C15
MY1B63□	56	15	18	10	17.5	1.1	

(Machine the mounting side to the dimensions below.)

- D-□
- X□
- Individual -X□
- Technical data

Series MY1B

Standard Type/Centralized Piping Type $\phi 80, \phi 100$

Refer to page 1056 regarding centralized piping port variations.

MY1B80□/100□ — Stroke

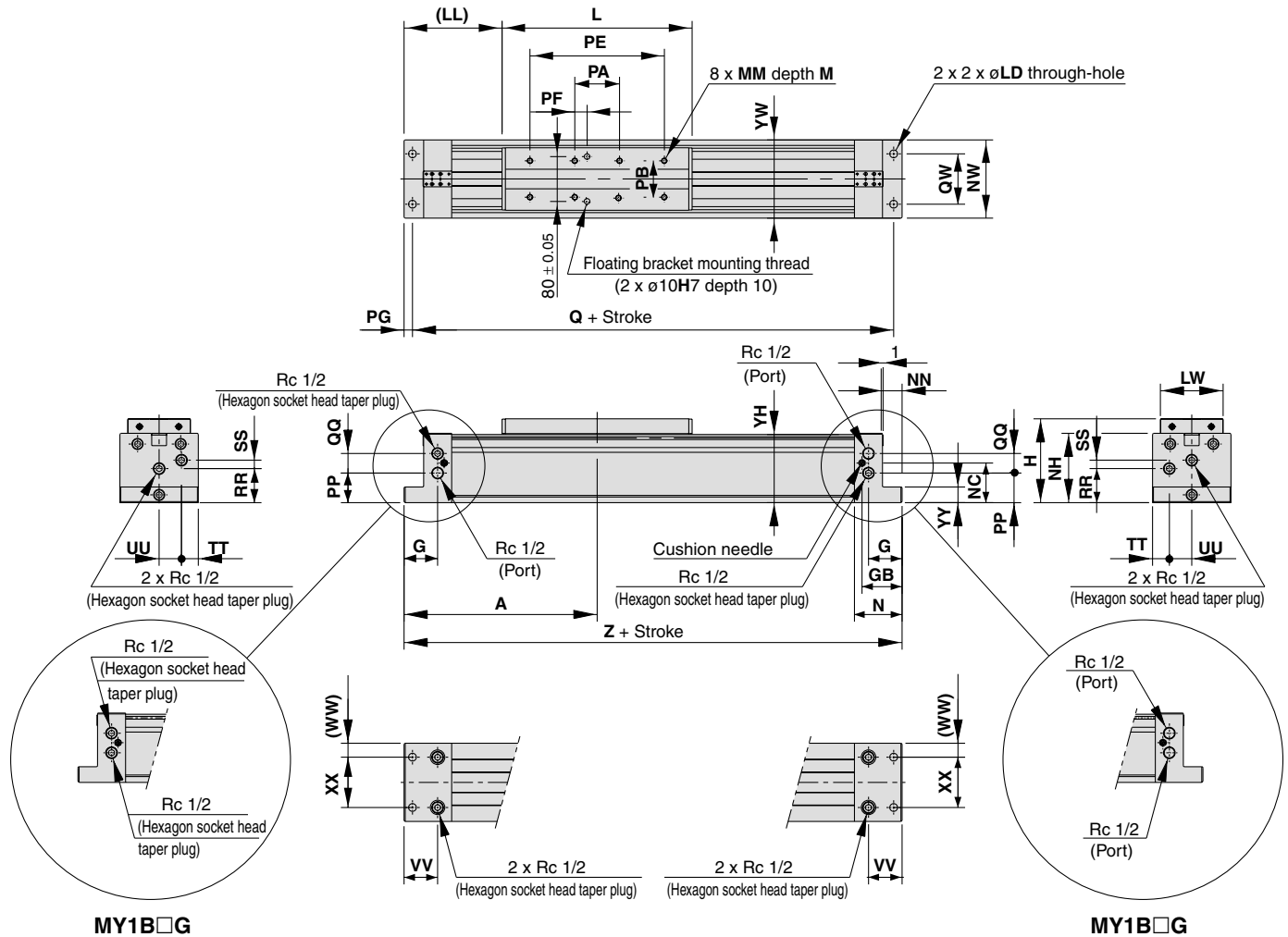

Model	A	G	GB	H	L	LD	LL	LW	M	MM	N	NC	NH	NN	NW	PA	PB	PE
MY1B 80□	345	60	71.5	150	340	14	175	112	20	M10 x 1.5	85	71	124	35	140	80	65	240
MY1B100□	400	70	79.5	190	400	18	200	140	25	M12 x 1.75	95	85	157	45	176	120	85	280

Model	PF	PG	PP	Q	QQ	QW	RR	SS	TT	UU	VV	WW	XX	YH	YW	YY	Z
MY1B 80□	22	15	53	660	35	90	61	15	30	40	60	25	90	122	140	28	690
MY1B100□	42	20	69	760	38	120	75	20	40	48	70	28	120	155	176	35	800

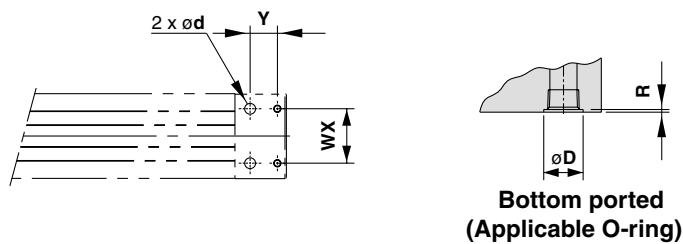

Hole Size for Centralized Piping on the Bottom

Model	WX	Y	d	D	R	Applicable O-ring
MY1B 80□	90	45	18	26	1.8	P22
MY1B100□	120	50	18	26	1.8	

(Machine the mounting side to the dimensions below.)

Stroke Adjusting Unit

With adjusting bolt

MY1B Bore size — Stroke A

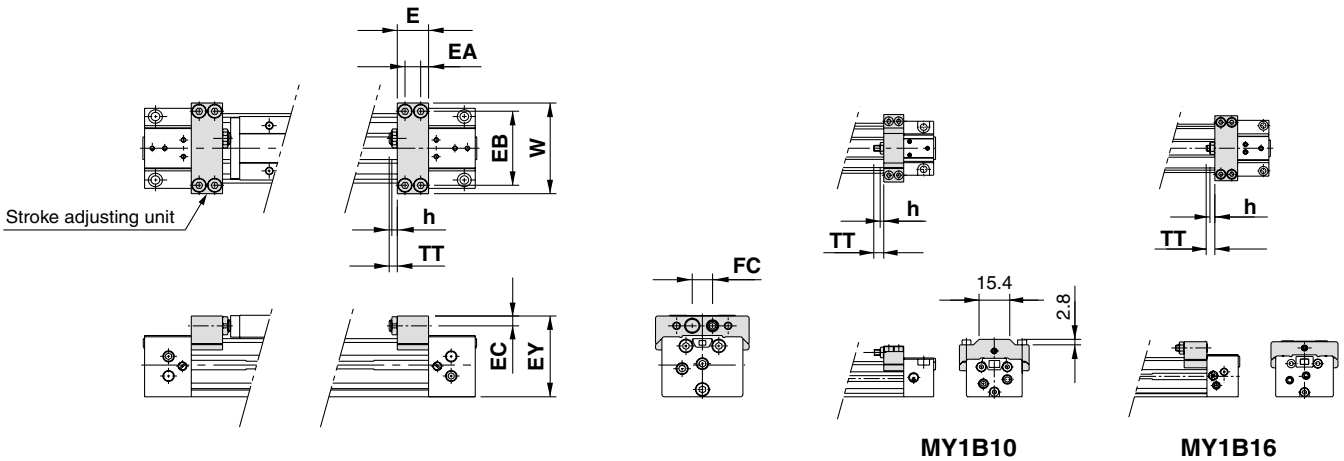

Applicable bore size	E	EA	EB	EC	EY	FC	h	TT	W
MY1B10	10	5	28	3.3	26.3	—	1.8	5 (Max. 10)	35
MY1B16	14.6	7	34.4	4.2	36.5	—	2.4	5.4 (Max. 11)	43
MY1B20	19	9	43	5.8	45.6	13	3.2	6 (Max. 12)	53
MY1B25	20	10	49	6.5	53.5	13	3.5	5 (Max. 16.5)	60
MY1B32	25	12	61	8.5	67	17	4.5	8 (Max. 20)	74
MY1B40	31	15	76	9.5	81.5	17	4.5	9 (Max. 25)	94

(mm)

MY1B

MY1M

MY1C

MY1H

MY1HT

MY1□W

MY2C

MY2H□

MY3A

MY3B

MY3M

With low load shock absorber + Adjusting bolt

MY1B Bore size — Stroke L

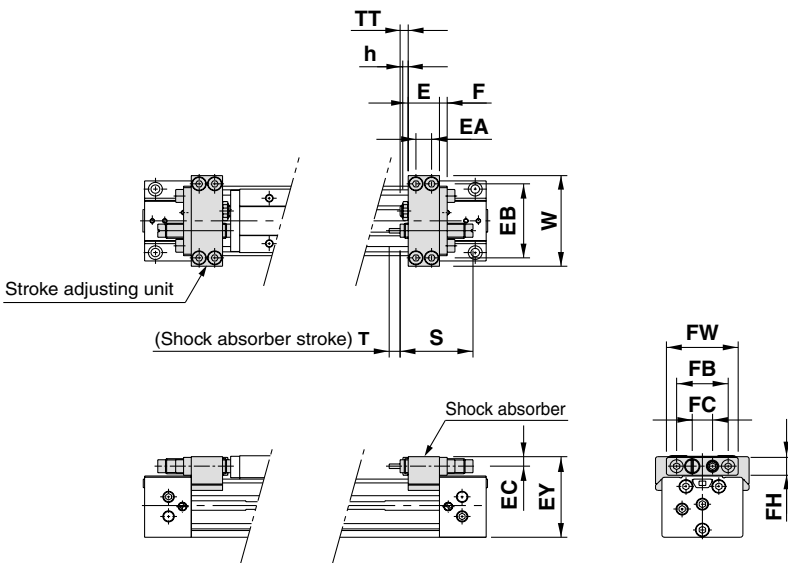

Applicable bore size	E	EA	EB	EC	EY	F	FB	FC	FH	FW	h	S	T	TT	W	Shock absorber model
MY1B20	19	9	43	5.8	45.6	4	—	13	—	—	3.2	40.8	6	6 (Max. 12)	53	RB0806
MY1B25	20	10	49	6.5	53.5	6	33	13	12	46	3.5	46.7	7	5 (Max. 16.5)	60	RB1007
MY1B32	25	12	61	8.5	67	6	43	17	16	56	4.5	67.3	12	8 (Max. 20)	74	RB1412
MY1B40	31	15	76	9.5	81.5	6	43	17	16	56	4.5	67.3	12	9 (Max. 25)	94	RB1412

(mm)

D-□

-X□

Individual

-X□

Technical data

Series MY1B

Stroke Adjusting Unit

With high load shock absorber + Adjusting bolt

MY1B Bore size □ — Stroke H

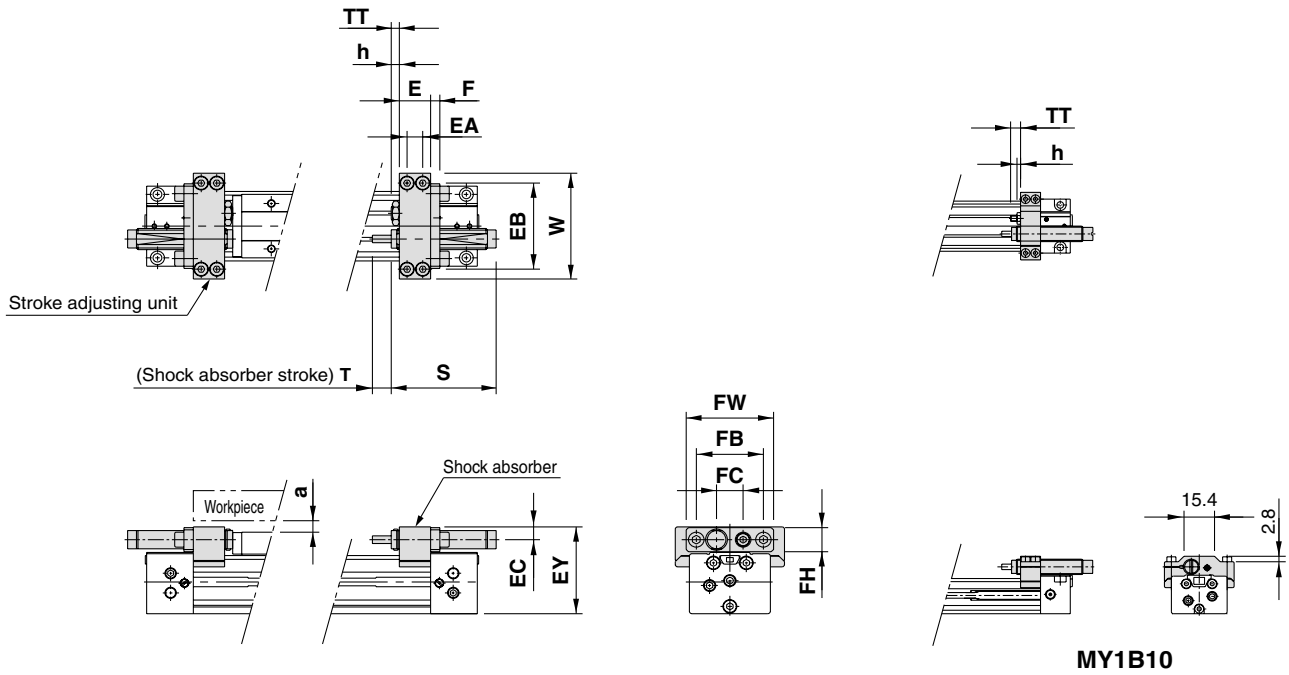

* Since the dimension EY of H unit is greater than the table top height (dimension H), when a workpiece is loaded that is larger than the full length (dimension L) of the slide table allow a clearance of size "a" or larger at the workpiece side.

Applicable bore size	E	EA	EB	EC	EY	F	FB	FC	FH	FW	h	S	T	TT	W	Shock absorber model	a
MY1B10	10	5	28	5.5	29.8	—	—	8	—	—	1.8	40.8	5	5 (Max. 10)	35	RB0805	3.5
MY1B20	20	10	49	6.5	47.5	6	33	13	12	46	3.5	46.7	7	5 (Max. 11)	60	RB1007	2.5
MY1B25	20	10	57	8.5	57.5	6	43	17	16	56	4.5	67.3	12	5 (Max. 16.5)	70	RB1412	4.5
MY1B32	25	12	74	11.5	73	8	57	22	22	74	5.5	73.2	15	8 (Max. 20)	90	RB2015	6
MY1B40	31	15	82	12	87	8	57	22	22	74	5.5	73.2	15	9 (Max. 25)	100	RB2015	4

Side Support

Side support A MY-S□A

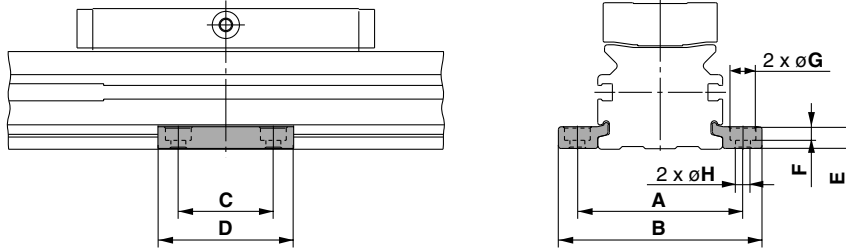

Side support B MY-S□B

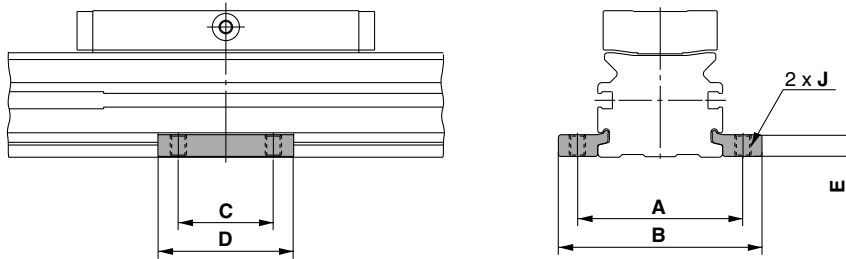

Model	Applicable bore size	A	B	C	D	E	F	G	H	J
MY-S10 ^A _B	MY1B 10	35	43.6	12	21	3.6	1.8	6.5	3.4	M4 x 0.7
MY-S16 ^A _B	MY1B 16	43	53.6	15	26	4.9	3	6.5	3.4	M4 x 0.7
MY-S20 ^A _B	MY1B 20	53	65.6	25	38	6.4	4	8	4.5	M5 x 0.8
MY-S25 ^A _B	MY1B 25	61	75	35	50	8	5	9.5	5.5	M6 x 1
	MY1B 32	70	84							
MY-S32 ^A _B	MY1B 40	87	105	45	64	11.7	6	11	6.6	M8 x 1.25
	MY1B 50	113	131							
MY-S50 ^A _B	MY1B 63	136	158	55	80	14.8	8.5	14	9	M10 x 1.5
MY-S63 ^A _B	MY1B 80	170	200	70	100	18.3	10.5	17.5	11.5	M12 x 1.75
	MY1B100	206	236							

* A set of side supports consists of a left support and a right support.

Guide for Side Support Application

For long stroke operation, the cylinder tube may be deflected depending on its own weight and the load weight. In such a case, use a side support in the middle section. The spacing (ℓ) of the support must be no more than the values shown in the graph on the right.

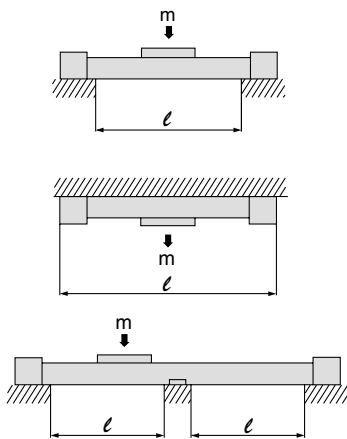

Caution

1. If the cylinder mounting surfaces are not measured accurately, using a side support may cause poor operation. Therefore, be sure to level the cylinder tube when mounting. Also, for long stroke operation involving vibration and impact, use of a side support is recommended even if the spacing value is within the allowable limits shown in the graph.
2. Support brackets are not for mounting; use them solely for providing support.

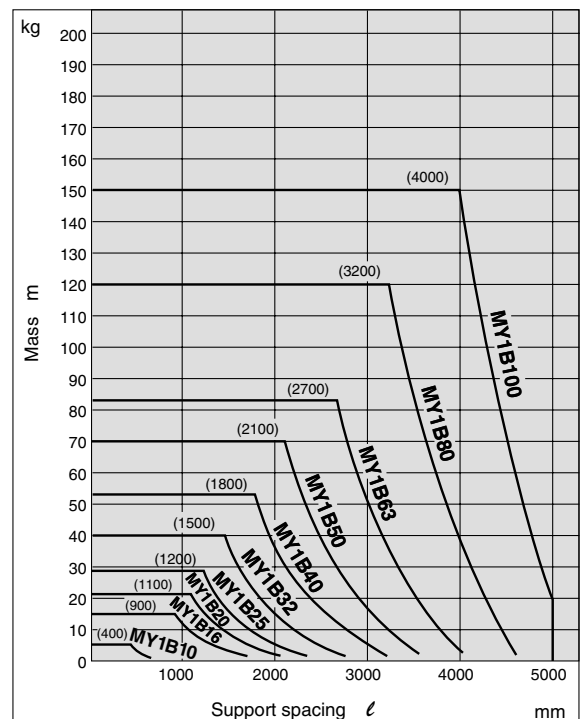

MY1B

MY1M

MY1C

MY1H

MY1HT

MY1□W

MY2C

MY2H□

MY3A

MY3B

MY3M

D-□

-X□

Individual

-X□

Technical data

Series MY1B

Floating Bracket

Facilitates connection to other guide systems.

Applicable bore size

ø10

MY-J10

Application Example

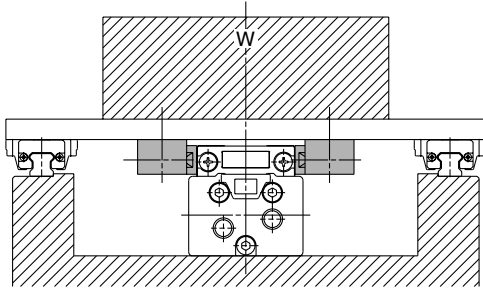

Mounting Example

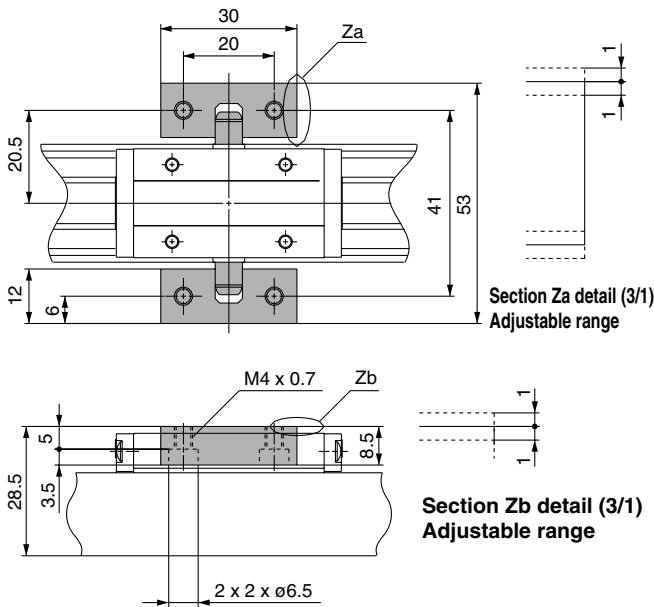

Note) A set of brackets with floating mechanism consists of a left bracket and a right bracket.

Applicable bore size

ø16, ø20

MY-J16/MY-J20

Application Example

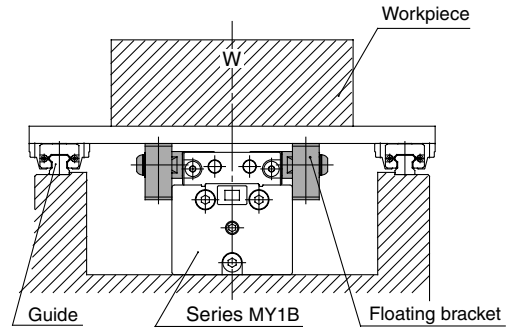

Mounting Example

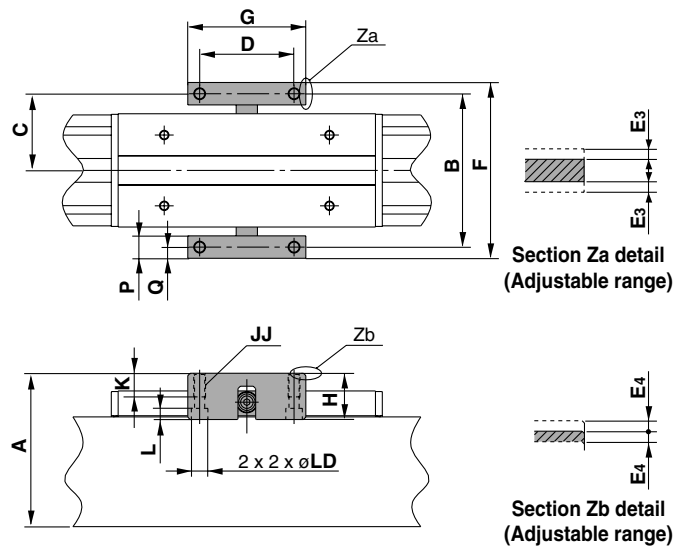

(mm)

Model	Applicable bore size	A	B	C	D	F	G	H
MY-J16	MY1B16□	45	45	22.5	30	52	38	18
MY-J20	MY1B20□	55	52	26	35	59	50	21

Model	Applicable bore size	JJ	K	L	P	Q	E ₃	E ₄	LD
MY-J16	MY1B16□	M4 x 0.7	10	4	7	3.5	1	1	6
MY-J20	MY1B20□	M4 x 0.7	10	4	7	3.5	1	1	6

Note) A set of brackets with floating mechanism consists of a left bracket and a right bracket.

Installation of Holding Bolts

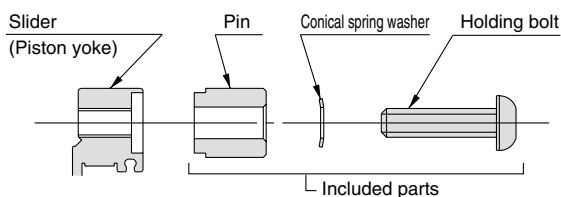

Tightening Torque for Holding Bolts (N·m)

Model	Tightening torque	Model	Tightening torque	Model	Tightening torque
MY-J10	0.6	MY-J25	3	MY-J50	5
MY-J16	1.5	MY-J32	5	MY-J63	13
MY-J20	1.5	MY-J40	5		

MY-J10 to 63 (1 set) Component Parts

Description	Qty.
Bracket	2
Pin	2
Conical spring washer	2
Holding bolt	2

Applicable bore size

ø25, ø32, ø40

MY-J25/MY-J32/MY-J40

Application Example

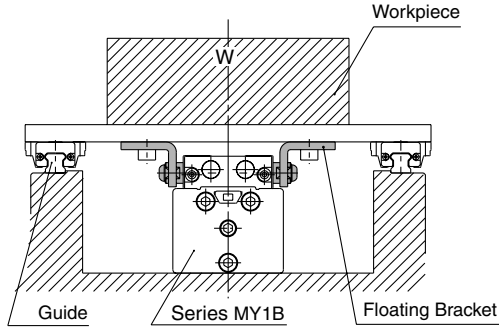

Mounting Example

One set of brackets can be mounted in two directions for compact combinations.

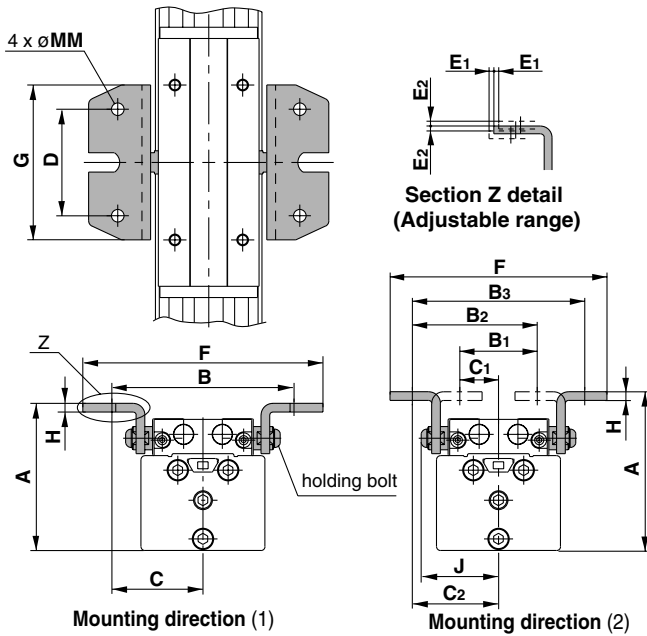

Model	Applicable bore size	Common					Mounting direction (1)			
		D	G	H	J	MM	A	B	C	F
MY-J25	MY1B25□	40	60	3.2	35	5.5	63	78	39	100
MY-J32	MY1B32□	55	80	4.5	40	6.5	76	94	47	124
MY-J40	MY1B40□	74	100	4.5	47	6.5	92	112	56	144

Model	Applicable bore size	Mounting direction (2)						Adjustable range		
		A	B ₁	B ₂	B ₃	C ₁	C ₂	F	E ₁	E ₂
MY-J25	MY1B25□	65	28	53	78	14	39	96	1	1
MY-J32	MY1B32□	82	40	64	88	20	44	111	1	1
MY-J40	MY1B40□	98	44	76	108	22	54	131	1	1

Note) A set of brackets with floating mechanism consists of a left bracket and a right bracket.

Applicable bore size

ø50, ø63

MY-J50/MY-J63

Application Example

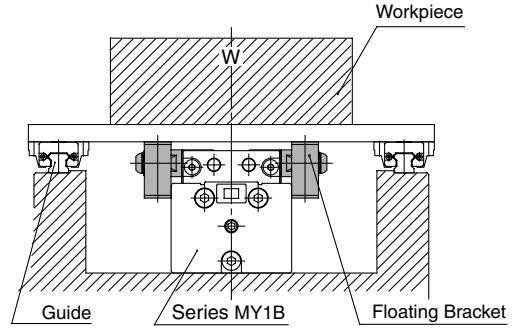

Mounting Example

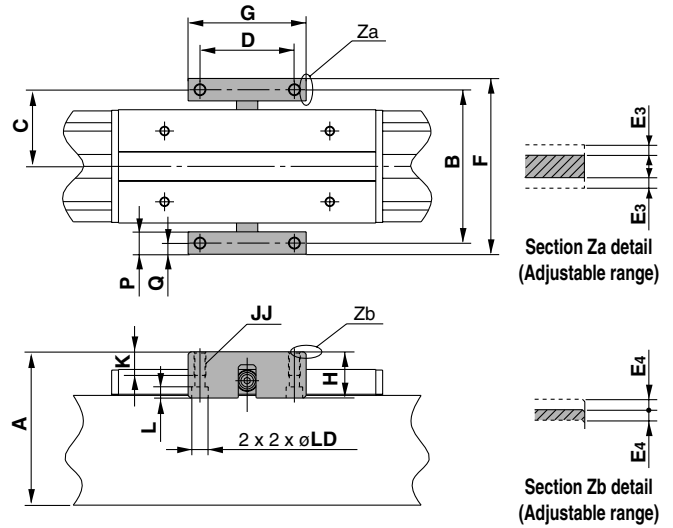

Model	Applicable bore size	(mm)							
		A	B	C	D	F	G	H	LD
MY-J50	MY1B50□	110	110	55	70	126	90	37	
MY-J63	MY1B63□	131	130	65	80	149	100	37	

Model	Applicable bore size	(mm)								
		JJ	K	L	P	Q	E ₃	E ₄	LD	
MY-J50	MY1B50□	M8 x 1.25	20	7.5	16	8	2.5	2.5	11	
MY-J63	MY1B63□	M10 x 1.5	20	9.5	19	9.5	2.5	2.5	14	

Note) A set of brackets with floating mechanism consists of a left bracket and a right bracket.

MY1B

MY1M

MY1C

MY1H

MY1HT

MY1□W

MY2C

MY2H□

MY3A

MY3B

MY3M

D-□

-X□

Individual

-X□

Technical data

Series MY1B

Floating Bracket

Facilitates connection to other guide systems.

Applicable bore size

ø80, ø100

MY-J80/MY-J100

Application Example

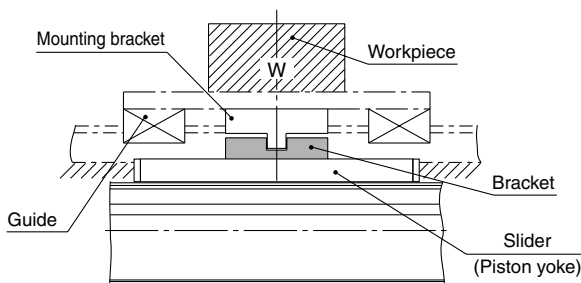

Mounting Example

Support bracket mounting area is heat treated at Hrc40 or above.

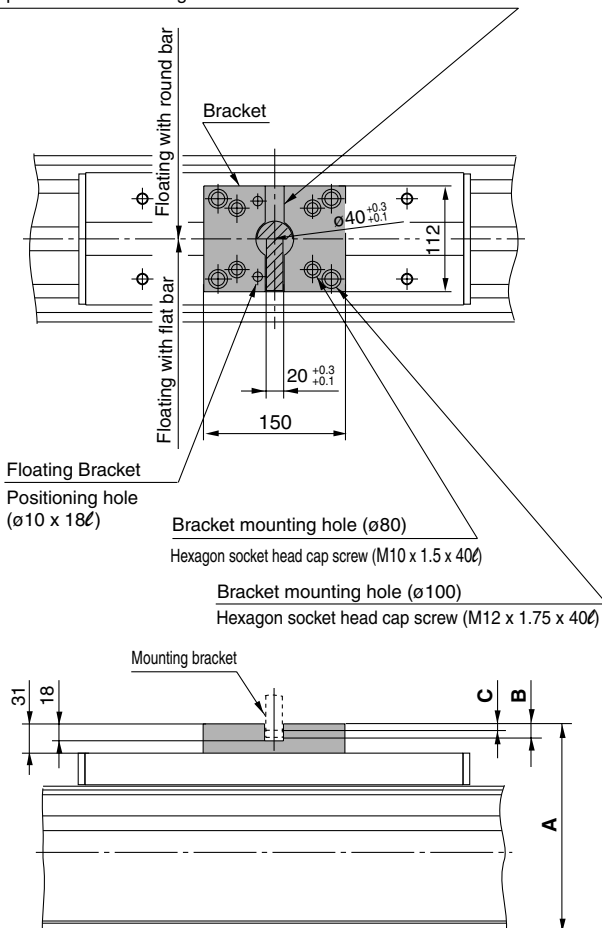

Hexagon Socket Head Cap Screw Tightening Torque (N·m)

Model	Applicable bore size	A	B (max.)	C (min.)	Model	Tightening torque
MY-J 80	MY1B 80□	181	15	9	MY-J 80	25
MY-J100	MY1B100□	221	15	9	MY-J100	44

Note) • Flat bar or round bar mounting are possible for the support bracket (slanted lines) mounted by the customer.
 • "B" and "C" indicate the allowable mounting dimensions for the support bracket (flat bar or round bar).
 • Consider support brackets with dimensions that allow the floating mechanism to function properly.

Floating Bracket Operating Precautions

⚠ Caution

When connecting to a load which has an external guide mechanism, use a discrepancy absorption mechanism.

Mount the external guide mounting brackets and floating brackets in a place where the required degree of freedom for the floating Y and Z axes can be secured.

The thrust transmission area of the floating bracket must be fixed so that it does not partially contact with the body.

* Confirm the Coordinates and Moments in Model Selection on page 947 for the details of floating Y and Z axes.

MY-J80, 100 (1 set) Component Parts

Description	Qty.
Bracket	1
Parallel pin	2
Holding bolt	4

Series *MY1M*

Slide Bearing Guide Type

ø16, ø20, ø25, ø32, ø40, ø50, ø63

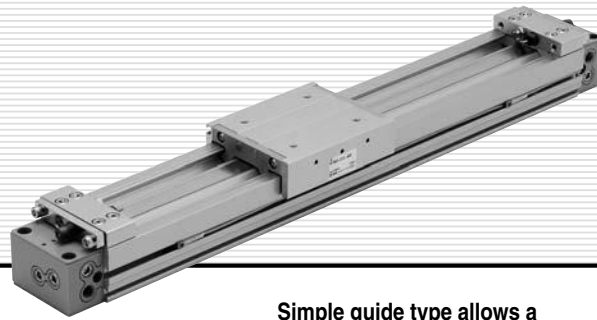

Simple guide type allows a workpiece to be mounted directly.

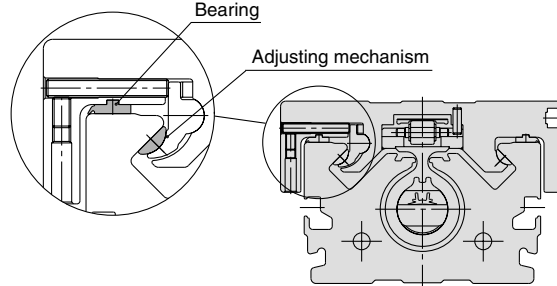

MY1B

MY1M

MY1C

MY1H

MY1HT

MY1□W

MY2C

MY2H□

MY3A
MY3B

MY3M

D-□

-X□

Individual
-X□

Technical
data

Maximum Allowable Moment/Maximum Load Mass

Model	Bore size (mm)	Maximum allowable moment (N·m)			Maximum load mass (kg)		
		M ₁	M ₂	M ₃	m ₁	m ₂	m ₃
MY1M	16	6.0	3.0	1.0	18	7	2.1
	20	10	5.2	1.7	26	10.4	3
	25	15	9.0	2.4	38	15	4.5
	32	30	15	5.0	57	23	6.6
	40	59	24	8.0	84	33	10
	50	115	38	15	120	48	14
	63	140	60	19	180	72	21

The above values are the maximum allowable values for moment and load. Refer to each graph regarding the maximum allowable moment and maximum allowable load for a particular piston speed.

Maximum Allowable Moment

Select the moment from within the range of operating limits shown in the graphs. Note that the maximum allowable load value may sometimes be exceeded even within the operating limits shown in the graphs. Therefore, also check the allowable load for the selected conditions.

Load mass (kg)

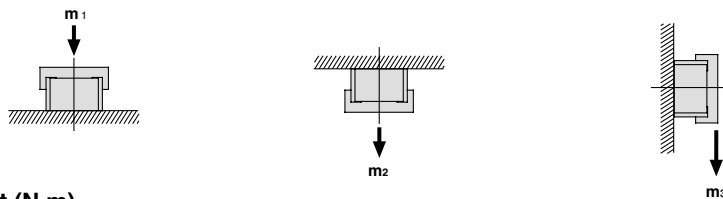

Moment (N·m)

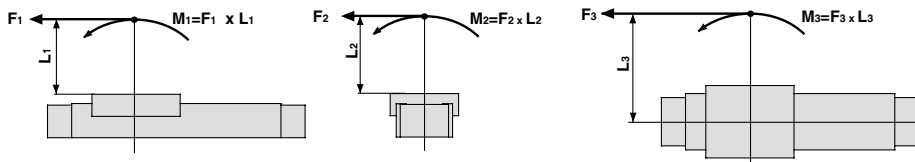

<Calculation of guide load factor>

1. Maximum allowable load (1), static moment (2), and dynamic moment (3) (at the time of impact with stopper) must be examined for the selection calculations.

* To evaluate, use \bar{v}_a (average speed) for (1) and (2), and v (collision speed $v = 1.4\bar{v}_a$) for (3). Calculate m_{max} for (1) from the maximum allowable load graph (m_1, m_2, m_3) and M_{max} for (2) and (3) from the maximum allowable moment graph (M_1, M_2, M_3).

$$\text{Sum of guide load factors } \Sigma\alpha = \frac{\text{Load mass [m]}}{\text{Maximum allowable load [mmax]}} + \frac{\text{Static moment [M]}^{(1)}}{\text{Allowable static moment [Mmax]}} + \frac{\text{Dynamic moment [ME]}^{(2)}}{\text{Allowable dynamic moment [Mmax]}} \leq 1$$

Note 1) Moment caused by the load, etc., with cylinder in resting condition.

Note 2) Moment caused by the impact load equivalent at the stroke end (at the time of impact with stopper).

Note 3) Depending on the shape of the workpiece, multiple moments may occur. When this happens, the sum of the load factors ($\Sigma\alpha$) is the total of all such moments.

Maximum Load Mass

Select the load from within the range of limits shown in the graphs. Note that the maximum allowable moment value may sometimes be exceeded even within the operating limits shown in the graphs. Therefore, also check the allowable moment for the selected conditions.

2. Reference formula [Dynamic moment at impact]

Use the following formulae to calculate dynamic moment when taking stopper impact into consideration.

- m:** Load mass (kg)
- F:** Load (N)
- F_E:** Load equivalent to impact (at impact with stopper) (N)
- \bar{v}_a :** Average speed (mm/s)
- M:** Static moment (N·m)
- v :** Collision speed (mm/s)
- L₁:** Distance to the load's center of gravity (m)
- M_E:** Dynamic moment (N·m)
- δ :** Damper coefficient At collision: $v = 1.4\bar{v}_a$
With rubber bumper = 4/100
(MY1B10, MY1H10)
With air cushion = 1/100
With shock absorber = 1/100
- g:** Gravitational acceleration (9.8 m/s²)

$$v = 1.4\bar{v}_a \quad F_E = 1.4\bar{v}_a \cdot \delta \cdot m \cdot g$$

$$\therefore M_E = \frac{1}{3} \cdot F_E \cdot L_1 = 4.57\bar{v}_a \delta m L_1 \text{ (N·m)}$$

Note 4) $1.4\bar{v}_a \delta$ is a dimensionless coefficient for calculating impact force.

Note 5) Average load coefficient ($= \frac{1}{3}$): This coefficient is for averaging the maximum load moment at the time of stopper impact according to service life calculations.

3. For detailed selection procedures, refer to pages 978 and 979.

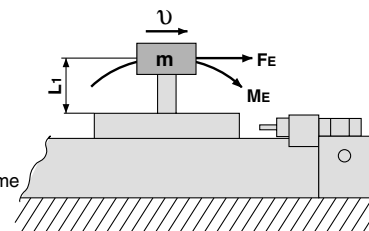

MY1M/M₁

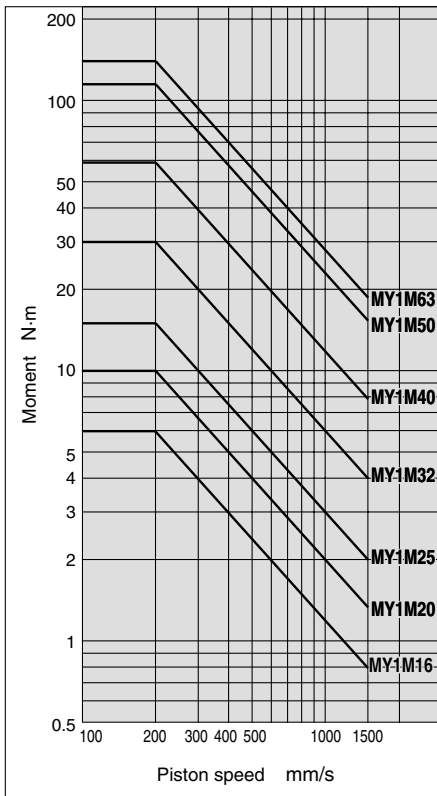

MY1M/M₂

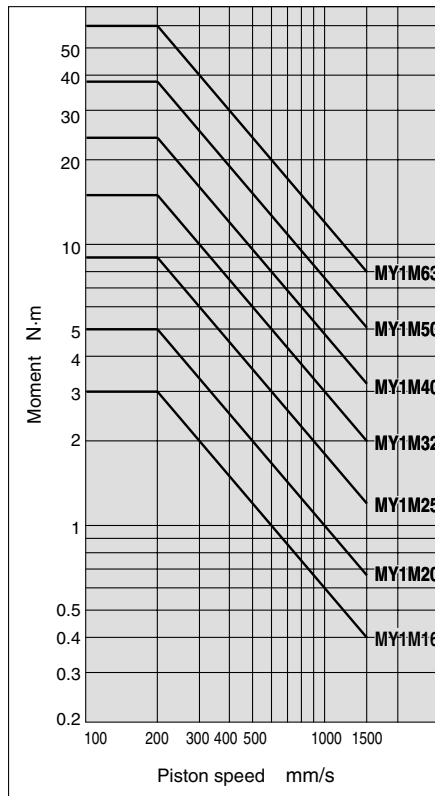

MY1M/M₃

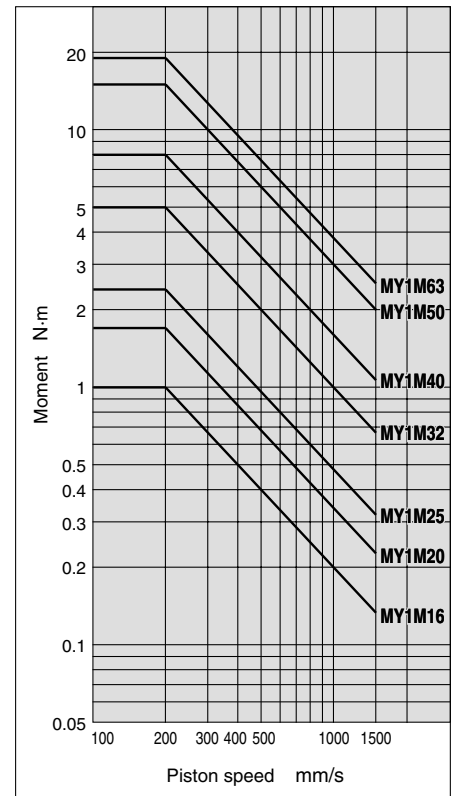

MY1B

MY1M

MY1C

MY1H

MY1HT

MY1□W

MY2C

MY2H□

MY3A

MY3B

MY3M

MY1M/m₁

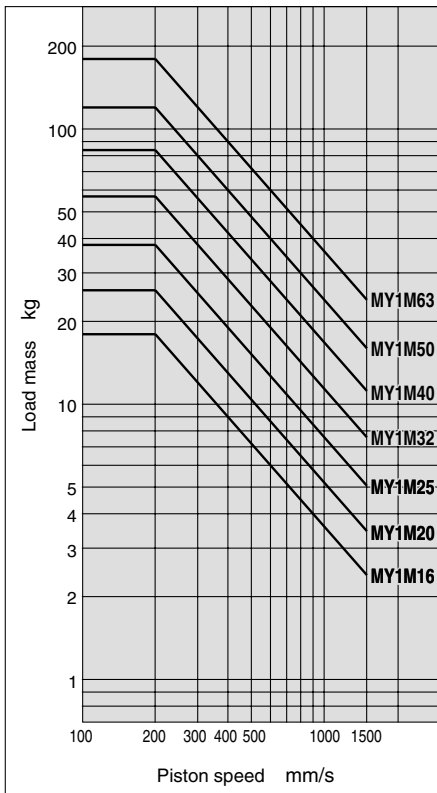

MY1M/m₂

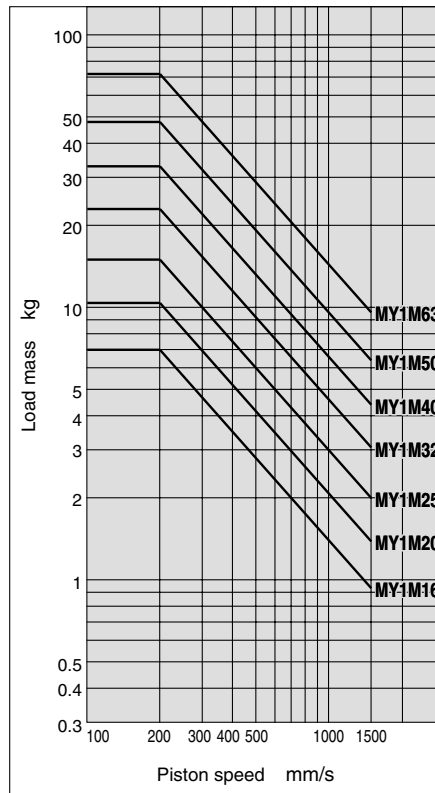

MY1M/m₃

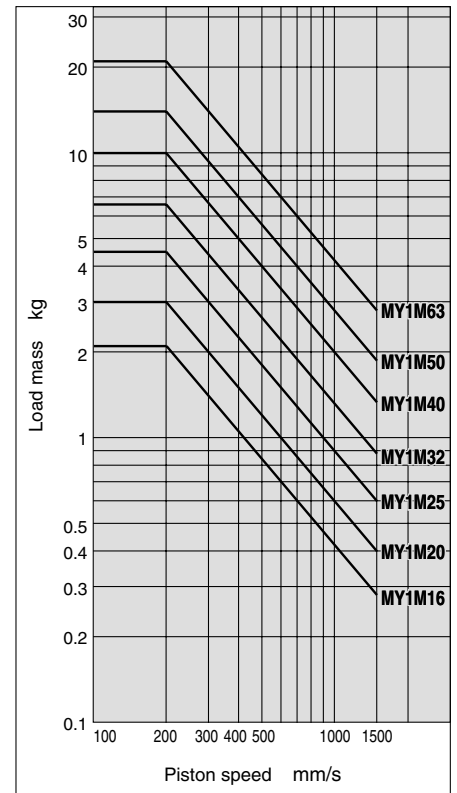

D-□

-X□

Individual

-X□

Technical

data

Model Selection

Following are the steps for selecting the most suitable Series MY1M to your application.

Calculation of Guide Load Factor

1. Operating Conditions

Cylinder MY1M40-500

Average operating speed v_a ... 200 mm/s

Mounting orientation Horizontal mounting W_d : Workpiece (500 g)

Cushion Air cushion
($\delta = 1/100$)

W_a : Connection plate $t = 10$ (880 g)

W_c : MHL2-16D1 (795 g)

MY1M40-500

W_b : MGGLB25-200 (4.35 kg)

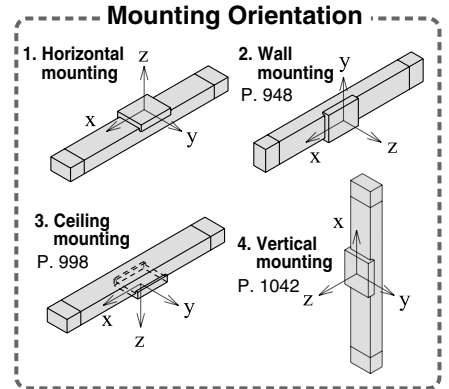
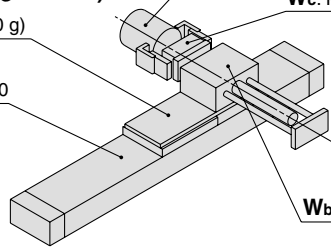

For actual examples of calculation for each orientation, refer to the pages above.

2. Load Blocking

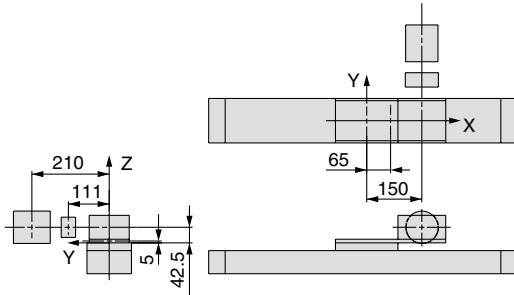

Mass and Center of Gravity for Each Workpiece

Workpiece no. W_n	Mass m_n	Center of gravity		
		X-axis X_n	Y-axis Y_n	Z-axis Z_n
W_a	0.88 kg	65 mm	0 mm	5 mm
W_b	4.35 kg	150 mm	0 mm	42.5 mm
W_c	0.795 kg	150 mm	111 mm	42.5 mm
W_d	0.5 kg	150 mm	210 mm	42.5 mm

$n=a, b, c, d$

3. Composite center of Gravity Calculation

$$m_1 = \sum m_n$$

$$= 0.88 + 4.35 + 0.795 + 0.5 = \mathbf{6.525 \text{ kg}}$$

$$X = \frac{1}{m_1} \times \sum (m_n \times X_n)$$

$$= \frac{1}{6.525} (0.88 \times 65 + 4.35 \times 150 + 0.795 \times 150 + 0.5 \times 150) = \mathbf{138.5 \text{ mm}}$$

$$Y = \frac{1}{m_1} \times \sum (m_n \times Y_n)$$

$$= \frac{1}{6.525} (0.88 \times 0 + 4.35 \times 0 + 0.795 \times 111 + 0.5 \times 210) = \mathbf{29.6 \text{ mm}}$$

$$Z = \frac{1}{m_1} \times \sum (m_n \times Z_n)$$

$$= \frac{1}{6.525} (0.88 \times 5 + 4.35 \times 42.5 + 0.795 \times 42.5 + 0.5 \times 42.5) = \mathbf{37.4 \text{ mm}}$$

4. Calculation of load factor for static load

m_1 : Mass

$m_1 \text{ max}$ (from (1) of graph MY1M/ m_1) = 84 (kg).....

Load factor $\alpha_1 = m_1 / m_1 \text{ max} = 6.525 / 84 = 0.08$

M_1 : Moment

$M_1 \text{ max}$ (from (2) of graph MY1M/ M_1) = 59 (N·m).....

$M_1 = m_1 \times g \times X = 6.525 \times 9.8 \times 138.5 \times 10^{-3} = 8.86 \text{ (N·m)}$

Load factor $\alpha_2 = M_1 / M_1 \text{ max} = 8.86 / 59 = 0.15$

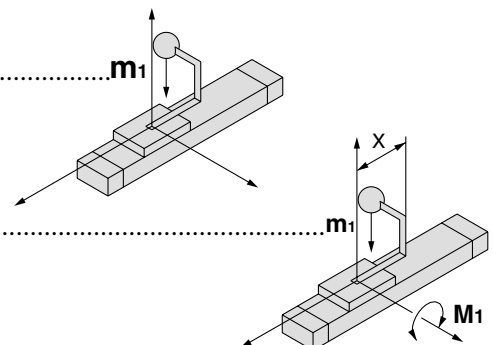

M_2 : Moment

$M_2 \text{ max}$ (from (3) of graph MY1M/ M_2) = 24 (N·m).....

$M_3 = m_1 \times g \times Y = 6.525 \times 9.8 \times 29.6 \times 10^{-3} = 1.89$ (N·m)

Load factor $\alpha_3 = M_2/M_2 \text{ max} = 1.89/24 = 0.08$

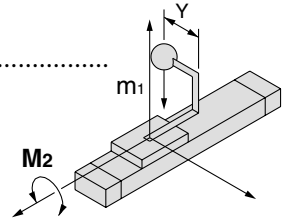

5. Calculation of Load Factor for Dynamic Moment

Equivalent load F_E at impact

$$F_E = 1.4va \times \delta \times m \times g = 1.4 \times 200 \times \frac{1}{100} \times 6.525 \times 9.8 = 179.1 \text{ (N)}$$

M_{1E} : Moment

$M_{1E} \text{ max}$ (from (4) of graph MY1M/ M_1 where $1.4va = 280$ mm/s) = 42.1 (N·m).....

$$M_{1E} = \frac{1}{3} \times F_E \times Z = \frac{1}{3} \times 179.1 \times 37.4 \times 10^{-3} = 2.23 \text{ (N·m)}$$

Load factor $\alpha_4 = M_{1E}/M_{1E} \text{ max} = 2.23/42.1 = 0.05$

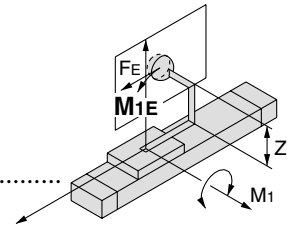

M_{3E} : Moment

$M_{3E} \text{ max}$ (from (5) of graph MY1M/ M_3 where $1.4va = 280$ mm/s) = 5.7 (N·m).....

$$M_{3E} = \frac{1}{3} \times F_E \times Y = \frac{1}{3} \times 179.1 \times 29.6 \times 10^{-3} = 1.77 \text{ (N·m)}$$

Load factor $\alpha_5 = M_{3E}/M_{3E} \text{ max} = 1.77/5.7 = 0.31$

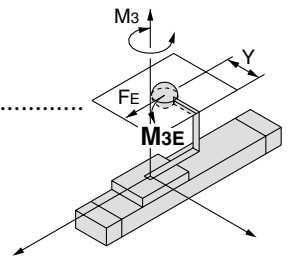

6. Sum and Examination of Guide Load Factors

$$\sum \alpha = \alpha_1 + \alpha_2 + \alpha_3 + \alpha_4 + \alpha_5 = 0.67 \leq 1$$

The above calculation is within the allowable value, and therefore the selected model can be used.

Select a shock absorber separately.

In an actual calculation, when the total sum of guide load factors $\sum \alpha$ in the formula above is more than 1, consider either decreasing the speed, increasing the bore size, or changing the product series. This calculation can be easily made using the "SMC Pneumatics CAD System".

Load Mass

MY1M/ m_1

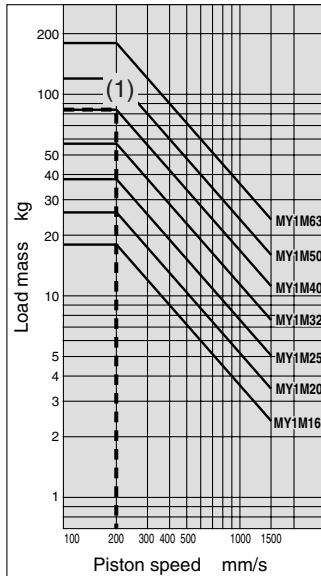

Allowable Moment

MY1M/ M_1

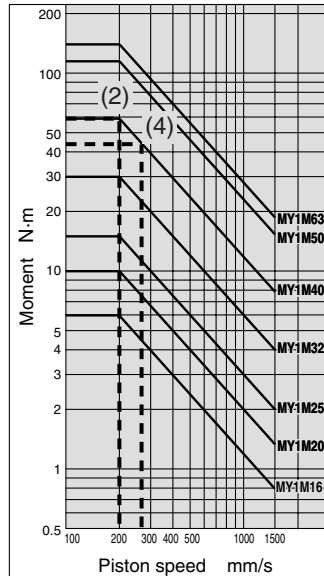

MY1M/ M_2

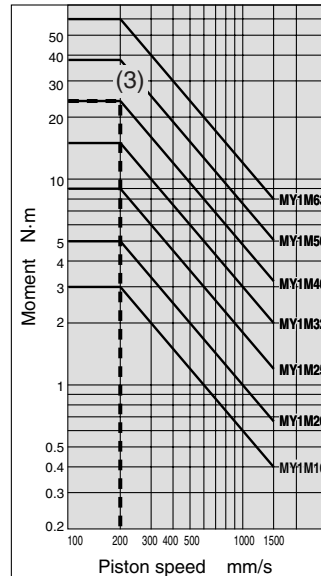

MY1M/ M_3

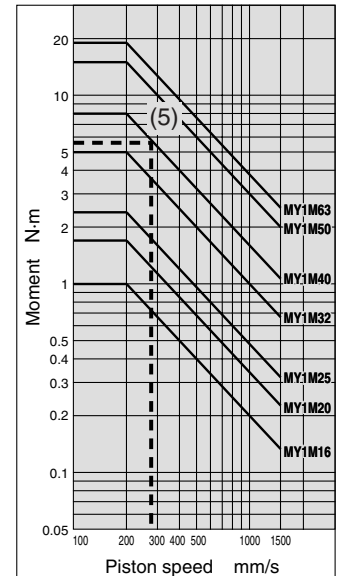

MY1B

MY1M

MY1C

MY1H

MY1HT

MY1□W

MY2C

MY2H□

MY3A

MY3B

MY3M

D-□

-X□

Individual

-X□

Technical data

Mechanically Jointed Rodless Cylinder Slide Bearing Guide Type

Series MY1M

ø16, ø20, ø25, ø32, ø40, ø50, ø63

How to Order

Slide bearing guide type MY1M 20 G - 300 L S - M9BW

Slide bearing guide type

Bore size (mm)

16	16 mm
20	20 mm
25	25 mm
32	32 mm
40	40 mm
50	50 mm
63	63 mm

Port thread type

Symbol	Type	Bore size
Nil	M thread	ø16, ø20
	Rc	ø25, ø32,
TN	NPT	ø40, ø50,
TF	G	ø63

Piping

Nil	Standard type
G	Centralized piping type

Stroke (mm)
Refer to "Standard Stroke" on page 981.

Stroke adjusting unit

Nil	Without adjusting unit
A	With adjusting bolt
L	With low load shock absorber + Adjusting bolt
H	With high load shock absorber + Adjusting bolt
AL	With one A unit and one L unit
AH	With one A unit and one H unit each
LH	With one L unit and one H unit each

Number of auto switches

Nil	2 pcs.
S	1 pc.
n	"n" pcs.

Made to Order
Refer to page 981 for details.

Suffix for stroke adjusting unit

Nil	Both ends
S	One end

Note) "S" is applicable for stroke adjusting units A, L and H.

Auto switch

Nil	Without auto switch (Built-in magnet)
-----	---------------------------------------

Applicable auto switches vary depending on the bore size. Select an applicable one referring to the table below.

Shock Absorbers for L and H Units

Bore size (mm)	16	20	25	32	40	50	63
L unit	RB0806	RB1007	RB1412	RB2015	RB2725		
H unit	—	RB1007	RB1412	RB2015	RB2725		

Note) MY1M16 is not available with H unit.

Applicable Auto Switch/Refer to pages 1263 to 1371 for further information on auto switches.

Type	Special function	Electrical entry	Indicator light	Wiring (Output)	Load voltage			Auto switch model				Lead wire length (m)				Pre-wired connector	Applicable load
					DC	AC	Perpendicular		In-line		0.5 (Nil)	1 (M)	3 (L)	5 (Z)			
							ø16, ø20	ø25 to ø63	ø16, ø20	ø25 to ø63							
Solid state switch	—	Grommet	Yes	3-wire (NPN)	24V	5V, 12V	—	M9NV **	M9N **	●	●	●	○	○	IC circuit	Relay, PLC	
								[Y69A]	[Y59A]	●	●	○	○				
								M9PV **	M9P **	●	●	○	○				
	[Y7PV]			[Y7P]	●	●	○	○									
	2-wire			5V, 12V	—	M9BV **	M9B **	●	●	○	○	—					
	[Y69B]					[Y59B]	●	●	○	○							
M9NWV **	M9NW **	●	●			○	○										
[Y7NWV]	[Y7NW]	●	●	○	○												
3-wire (NPN)	12V	—	M9PWV **	M9PW **	●	●	○	○	IC circuit								
[Y7PWV]			[Y7PW]	●	●	○	○										
M9BWV **			M9BW **	●	●	○	○										
[Y7BWV]	[Y7BW]	●	●	○	○												
Reed switch	—	Grommet	Yes	3-wire (NPN equivalent)	24V	5V	100V or less	A96V	A96	Z76	●	—	●	—	IC circuit	—	
				2-wire				A93V	A93	—	●	—	●	—	—		
				—				—	—	Z73	●	—	●	—	—		
			No					A90V	A90	Z80	●	—	●	—	IC circuit	Relay, PLC	

* Lead wire length symbols: 0.5 m Nil (Example) M9NW
 1 m M (Example) M9NWM
 3 m L (Example) M9NWL
 5 m Z (Example) M9NWZ

* Solid state auto switches marked with "O" are produced upon receipt of order.
 ** D-M9□□□ type cannot be mounted on ø25 to ø40.
 Select auto switches in brackets.

* There are other applicable auto switches than listed above. For details, refer to page 1053.
 * For details about auto switches with pre-wired connector, refer to pages 1328 and 1329.
 * Auto switches are shipped together (not assembled).

Mechanically Jointed Rodless Cylinder Slide Bearing Guide Type *Series MY1M*

Specifications



JIS Symbol

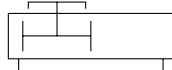

Bore size (mm)	16	20	25	32	40	50	63
Fluid	Air						
Action	Double acting						
Operating pressure range	0.15 to 0.8 MPa						
Proof pressure	1.2 MPa						
Ambient and fluid temperature	5 to 60°C						
Cushion	Air cushion						
Lubrication	Non-lube						
Stroke length tolerance	1000 or less $^{+1.8}_0$ 1001 to 3000 $^{+2.8}_0$		2700 or less $^{+1.8}_0$, 2701 to 5000 $^{+2.8}_0$				
Piping portsize	Front/Side port	M5 x 0.8		Rc 1/8		Rc 1/4	Rc 3/8
	Bottom port	ø4	ø5	ø6	ø8	ø10	ø11

Stroke Adjusting Unit Specifications

Bore size (mm)	16			20			25			32			40			50			63		
Unit symbol	A	L	H	A	L	H	A	L	H	A	L	H	A	L	H	A	L	H	A	L	H
Configuration Shock absorber model	With adjusting bolt	RB 0806 + with adjusting bolt	RB 1007 + with adjusting bolt	With adjusting bolt	RB 0806 + with adjusting bolt	RB 1007 + with adjusting bolt	With adjusting bolt	RB 1007 + with adjusting bolt	RB 1412 + with adjusting bolt	With adjusting bolt	RB 1412 + with adjusting bolt	RB 2015 + with adjusting bolt	With adjusting bolt	RB 1412 + with adjusting bolt	RB 2015 + with adjusting bolt	With adjusting bolt	RB 2015 + with adjusting bolt	RB 2725 + with adjusting bolt	With adjusting bolt	RB 2015 + with adjusting bolt	RB 2725 + with adjusting bolt
Fine stroke adjustment range (mm)	0 to -5			0 to -6			0 to -11.5			0 to -12			0 to -16			0 to -20			0 to -25		
Stroke adjustment range	When exceeding the stroke fine adjustment range: Utilize a made-to-order specifications "-X416" and "-X417".																				

* Stroke adjustment range is applicable for one side when mounted on a cylinder.

Shock Absorber Specifications

Model	RB 0806	RB 1007	RB 1412	RB 2015	RB 2725	
Max. energy absorption (J)	2.9	5.9	19.6	58.8	147	
Stroke absorption (mm)	6	7	12	15	25	
Max. collision speed (mm/s)	1500					
Max. operating frequency (cycle/min)	80	70	45	25	10	
Spring force (N)	Extended	1.96	4.22	6.86	8.34	8.83
	Retracted	4.22	6.86	15.98	20.50	20.01
Operating temperature range (°C)	5 to 60					

* The shock absorber service life is different from that of the MY1M cylinder depending on operating conditions. Refer to the RB Series Specific Product Precautions for the replacement period.

Piston Speed

Bore size (mm)	16 to 63	
Without stroke adjusting unit	100 to 1000 mm/s	
Stroke adjusting unit	A unit	100 to 1000 mm/s ⁽¹⁾
	L unit and H unit	100 to 1500 mm/s ⁽²⁾

Note 1) Be aware that when the stroke adjusting range is increased by manipulating the adjusting bolt, the air cushion capacity decreases. Also, when exceeding the air cushion stroke ranges on page 984, the piston speed should be 100 to 200 mm per second.

Note 2) The piston speed is 100 to 1000 mm/s for centralized piping.
Note 3) Use at a speed within the absorption capacity range. Refer to page 984.



Made to Order Specifications (For details, refer to pages 1395 to 1565.)

Symbol	Specifications
-XB11	Long stroke
-XC67	NBR rubber lining in dust seal band
-X168	Helical insert thread specifications
-X416	Holder mounting bracket I
-X417	Holder mounting bracket II

Standard Stroke

Bore size (mm)	Standard stroke (mm) *	Maximum manufacturable stroke (mm)
16	100, 200, 300, 400, 500, 600, 700 800, 900, 1000, 1200, 1400, 1600 1800, 2000	3000
20, 25, 32, 40 50, 63		5000

* Strokes are manufacturable in 1 mm increments, up to the maximum stroke. However, when exceeding a 2000 mm stroke, specify "-XB11" at the end of the model number.

MY1B

MY1M

MY1C

MY1H

MY1HT

MY1□W

MY2C

MY2H□

MY3A

MY3B

MY3M

D-□

-X□

Individual
-X□

Technical
data

Series MY1M

Theoretical Output

Bore size (mm)	Piston area (mm ²)	Operating pressure (MPa)						
		0.2	0.3	0.4	0.5	0.6	0.7	0.8
16	200	40	60	80	100	120	140	160
20	314	62	94	125	157	188	219	251
25	490	98	147	196	245	294	343	392
32	804	161	241	322	402	483	563	643
40	1256	251	377	502	628	754	879	1005
50	1962	392	588	784	981	1177	1373	1569
63	3115	623	934	1246	1557	1869	2180	2492

(N)
Note) Theoretical output (N) = Pressure (MPa) x Piston area (mm²)

Mass

Bore size (mm)	Basic mass	Additional mass per each 50mm of stroke	Side support mass (per set)	Stroke adjusting unit mass (per unit)		
			Type A and B	A unit mass	L unit mass	H unit mass
16	0.67	0.12	0.01	0.03	0.04	—
20	1.11	0.16	0.02	0.04	0.05	0.08
25	1.64	0.24	0.02	0.07	0.11	0.18
32	3.27	0.38	0.04	0.14	0.23	0.39
40	5.88	0.56	0.08	0.25	0.34	0.48
50	10.06	0.77	0.08	0.36	0.51	0.81
63	16.57	1.11	0.17	0.68	0.83	1.08

Calculation: (Example) MY1M25-300A

- Basic mass1.64 kg
 - Additional mass0.24/50 st
 - Mass of A unit0.07 kg
 - Cylinder stroke....300 st
- $$1.64 + 0.24 \times 300 \div 50 + 0.07 \times 2 \approx 3.22 \text{ kg}$$

Option

Stroke Adjusting Unit Part No.

Bore size (mm)		16	20	25	32	40	50	63
Unit no.	Left	MYM-A16A1	MYM-A20A1	MYM-A25A1	MYM-A32A1	MYM-A40A1	MYM-A50A1	MYM-A63A1
	Right	MYM-A16A2	MYM-A20A2	MYM-A25A2	MYM-A32A2	MYM-A40A2	MYM-A50A2	MYM-A63A2
L unit	Left	MYM-A16L1	MYM-A20L1	MYM-A25L1	MYM-A32L1	MYM-A40L1	MYM-A50L1	MYM-A63L1
	Right	MYM-A16L2	MYM-A20L2	MYM-A25L2	MYM-A32L2	MYM-A40L2	MYM-A50L2	MYM-A63L2
H unit	Left	—	MYM-A20H1	MYM-A25H1	MYM-A32H1	MYM-A40H1	MYM-A50H1	MYM-A63H1
	Right	—	MYM-A20H2	MYM-A25H2	MYM-A32H2	MYM-A40H2	MYM-A50H2	MYM-A63H2

Stroke adjusting unit form and mounting direction

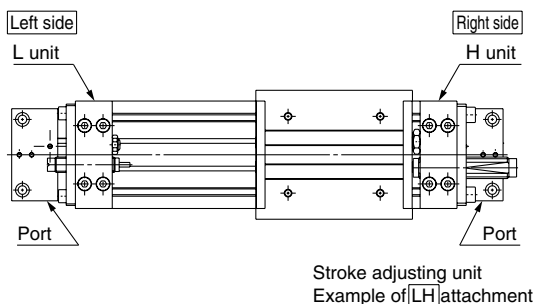

Side Support Part No.

Bore size (mm)		16	20	25	32	40	50	63
Type								
Side support A		MY-S16A	MY-S20A	MY-S25A	MY-S32A	MY-S40A	MY-S50A	MY-S63A
Side support B		MY-S16B	MY-S20B	MY-S25B	MY-S32B	MY-S40B	MY-S50B	MY-S63B

For details about dimensions, etc., refer to page 993.

A set of side supports consists of a left support and a right support.

Series MY1M

Cushion Capacity

Cushion Selection

<Air cushion>

Air cushions are a standard feature on mechanically jointed rodless cylinders. The air cushion mechanism is incorporated to prevent excessive impact of the piston at the stroke end during high speed operation. The purpose of air cushion, thus, is not to decelerate the piston near the stroke end. The ranges of load and speed that air cushions can absorb are within the air cushion limit lines shown in the graphs.

<Stroke adjusting unit with shock absorber>

Use this unit when operating with a load or speed exceeding the air cushion limit line, or when cushioning is required outside of the effective air cushion stroke range due to stroke adjustment.

<L unit>

Use this unit when the cylinder stroke is outside of the effective air cushion range even if the load and speed are within the air cushion limit line, or when the cylinder is operated in a load and speed range above the air cushion limit line or below the L unit limit line.

<H unit>

Use this unit when the cylinder is operated in a load and speed range above the L unit limit line and below the H unit limit line.

⚠ Caution

1. Refer to the figure below when using the adjusting bolt to perform stroke adjustment.

When the effective stroke of the shock absorber decreases as a result of stroke adjustment, the absorption capacity decreases dramatically. Secure the adjusting bolt at the position where it protrudes approximately 0.5 mm from the shock absorber.

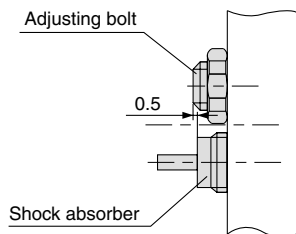

2. Do not use a shock absorber together with air cushion.

Air Cushion Stroke

(mm)

Bore size (mm)	Cushion stroke
16	12
20	15
25	15
32	19
40	24
50	30
63	37

Absorption Capacity of Air Cushion and Stroke Adjusting Units

MY1M16 Horizontal collision: P = 0.5 MPa

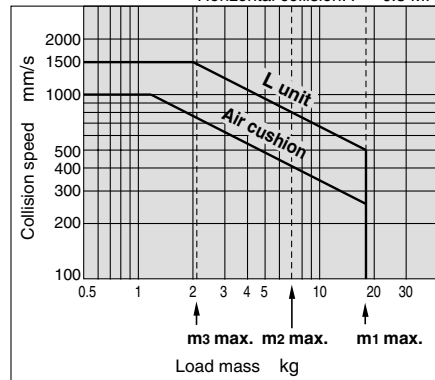

MY1M32 Horizontal collision: P = 0.5 MPa

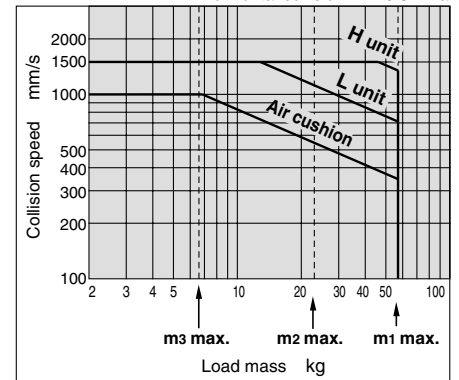

MY1M20 Horizontal collision: P = 0.5 MPa

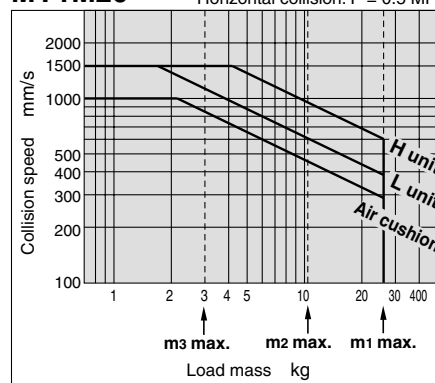

MY1M40 Horizontal collision: P = 0.5 MPa

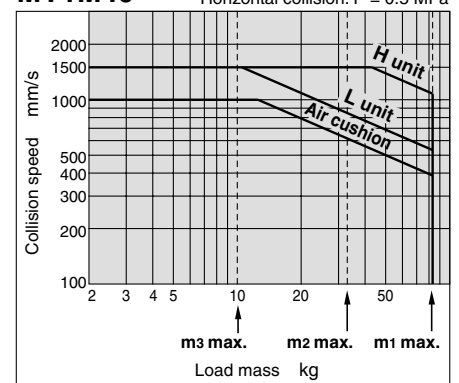

MY1M25 Horizontal collision: P = 0.5 MPa

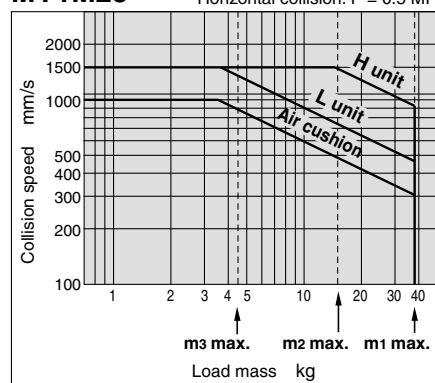

MY1M50 Horizontal collision: P = 0.5 MPa

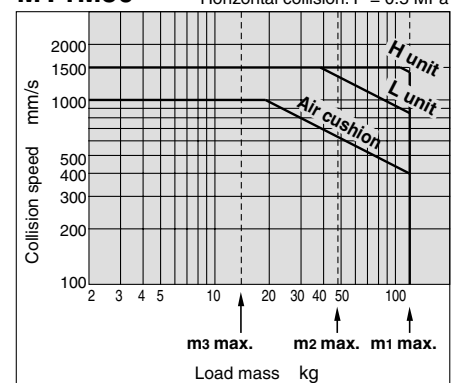

MY1M63 Horizontal collision: P = 0.5 MPa

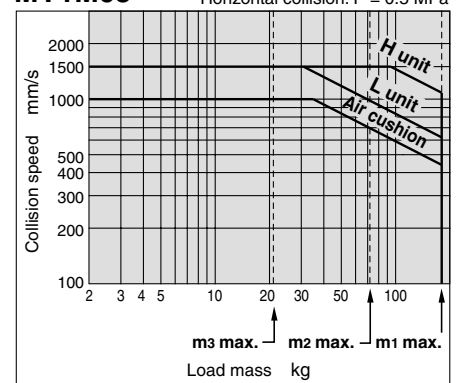

Tightening Torque for Stroke Adjusting Unit Holding Bolts (N·m)

Bore size (mm)	Unit	Tightening torque
16	A	0.7
	L	
20	A	1.8
	L	
	H	
25	A	3.5
	L	
	H	
32	A	5.8
	L	
	H	
40	A	13.8
	L	
	H	
50	A	13.8
	L	
	H	
63	A	27.5
	L	
	H	

Tightening Torque for Stroke Adjusting Unit Lock Plate Holding Bolts (N·m)

Bore size (mm)	Unit	Tightening torque
25	L	1.2
	H	3.3
32	L	3.3
	H	10
40	L	3.3
	H	10

Calculation of Absorbed Energy for Stroke Adjusting Unit with Shock Absorber (N·m)

Type of impact	Horizontal collision	Vertical (Downward)	Vertical (Upward)
Kinetic energy E_1		$\frac{1}{2} m \cdot v^2$	
Thrust energy E_2	$F \cdot s$	$F \cdot s + m \cdot g \cdot s$	$F \cdot s - m \cdot g \cdot s$
Absorbed energy E	$E_1 + E_2$		

Symbol

- v: Speed of impact object (m/s)
- F: Cylinder thrust (N)
- s: Shock absorber stroke (m)
- m: Mass of impact object (kg)
- g: Gravitational acceleration (9.8 m/s²)

Note) The speed of the impact object is measured at the time of impact with the shock absorber.

⚠ Precautions

Be sure to read before handling. Refer to front matters 54 and 55 for Safety Instructions and pages 3 to 11 for Actuator and Auto Switch Precautions.

⚠ Caution

Use caution not to get your hands caught in the unit.

- When using a product with stroke adjusting unit, the space between the slide table (slider) and the stroke adjusting unit becomes narrow at the stroke end, causing a danger of hands getting caught. Install a protective cover to prevent direct contact with the human body.

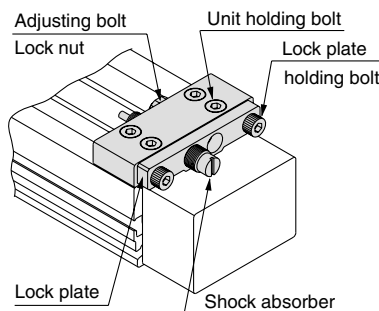

<Fastening of unit>

The unit can be secured by evenly tightening the four unit holding bolts.

⚠ Caution

Do not operate with the stroke adjusting unit fixed in an intermediate position.

When the stroke adjusting unit is fixed in an intermediate position, slippage can occur depending on the amount of energy released at the time of an impact. In such cases, the use of the adjusting bolt mounting brackets, available per made-to-order specifications -X416 and -X417, is recommended.

For other lengths, please consult with SMC (Refer to "Tightening Torque for Stroke Adjusting Unit Holding Bolts".)

<Stroke adjustment with adjusting bolt>

Loosen the adjusting bolt lock nut, and adjust the stroke from the lock plate side using a hexagon wrench. Retighten the lock nut.

<Stroke adjustment with shock absorber>

Loosen the two lock plate holding bolts, turn the shock absorber and adjust the stroke. Then, uniformly tighten the lock plate holding bolts to secure the shock absorber.

Take care not to over-tighten the holding bolts. (Except $\phi 16$, $\phi 20$, $\phi 50$, $\phi 63$) (Refer to "Tightening Torque for Stroke Adjusting Unit Lock Plate Holding Bolts".)

Note) Although the lock plate may slightly bend due to tightening of the lock plate holding bolt, this does not affect the shock absorber and locking function.

MY1B

MY1M

MY1C

MY1H

MY1HT

MY1□W

MY2C

MY2H□

MY3A

MY3B

MY3M

D-□

-X□

Individual

-X□

Technical data

Series MY1M

Construction: $\varnothing 16$ to $\varnothing 63$

MY1M16 to 63

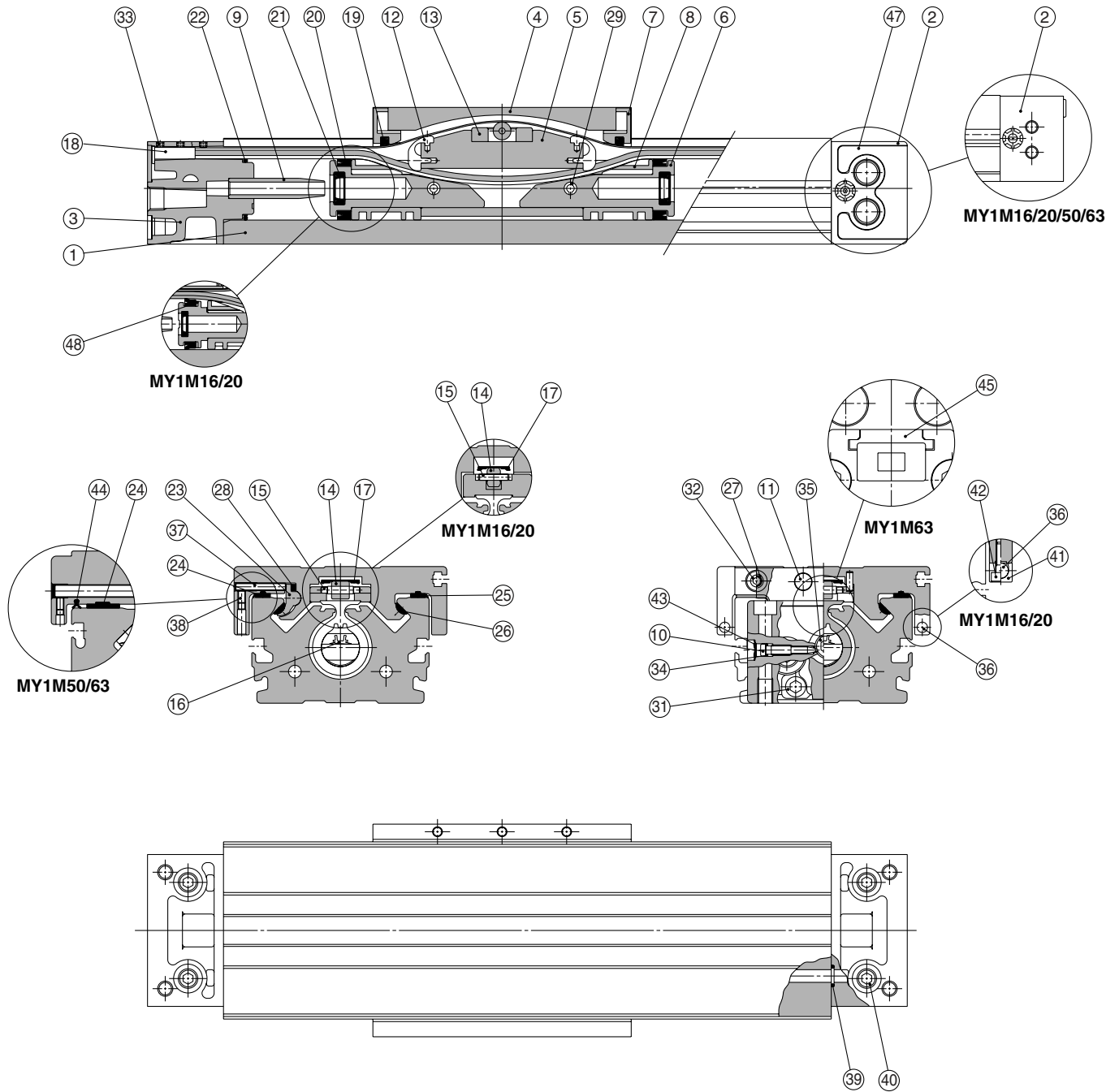

MY1M16 to 63

Component Parts

No.	Description	Material	Note
1	Cylinder tube	Aluminum alloy	Hard anodized
2	Head cover WR	Aluminum alloy	Painted
3	Head cover WL	Aluminum alloy	Painted
4	Slide table	Aluminum alloy	Hard anodized
5	Piston yoke	Aluminum alloy	Chromated
6	Piston	Aluminum alloy	Chromated
7	End cover	Special resin	
8	Wear ring	Special resin	
9	Cushion ring	Brass	
10	Cushion needle	Rolled steel	Nickel plated
11	Stopper	Carbon steel	Nickel plated
12	Belt separator	Special resin	
13	Coupler	Sintered iron material	
14	Guide roller	Special resin	
15	Guide roller shaft	Stainless steel	
18	Belt clamp	Special resin	
23	Adjusting arm	Aluminum alloy	Chromated
24	Bearing R	Special resin	
25	Bearing L	Special resin	
26	Bearing S	Special resin	

No.	Description	Material	Note
27	Spacer	Stainless steel	
28	Backup spring	Stainless steel	
29	Spring pin	Carbon tool steel	Black zinc chromated
31	Hexagon socket head cap screw	Chromium molybdenum steel	Nickel plated
32	Hexagon socket button head screw	Chromium molybdenum steel	Nickel plated
33	Hexagon socket head set screw	Chromium molybdenum steel	Black zinc chromated/Nickel plated
35	Hexagon socket head taper plug	Carbon steel	Nickel plated
36	Magnet	—	
37	Hexagon socket head set screw	Chromium molybdenum steel	Black zinc chromated
38	Hexagon socket head set screw	Chromium molybdenum steel	Black zinc chromated
40	Hexagon socket head taper plug	Carbon steel	Nickel plated
41	Magnet holder	Special resin	($\phi 16$, $\phi 20$)
42	Hexagon socket head cap screw	Chromium molybdenum steel	Nickel plated
43	Type CR retaining ring	Spring steel	
45	Head plate	Aluminum alloy	Hard anodized ($\phi 63$)
47	Port cover	Special resin	($\phi 25$ to $\phi 40$)
48	Lube retainer	Special resin	($\phi 16$, $\phi 20$)

Replacement Part: Seal Kit

No.	Description	Qty.	MY1M16	MY1M20	MY1M25	MY1M32	MY1M40	MY1M50	MY1M63
16	Seal belt	1	MY16-16A-Stroke	MY20-16A-Stroke	MY25-16A-Stroke	MY32-16A-Stroke	MY40-16A-Stroke	MY50-16A-Stroke	MY63-16A-Stroke
17	Dust seal band	1	MY16-16B-Stroke	MY20-16B-Stroke	MY25-16B-Stroke	MY32-16B-Stroke	MY40-16B-Stroke	MY50-16B-Stroke	MY63-16B-Stroke
34	O-ring	2	$\phi 4 \times \phi 1.8 \times \phi 1.1$	$\phi 5.1 \times \phi 3 \times \phi 1.05$	$\phi 5.1 \times \phi 3 \times \phi 1.05$	$\phi 7.15 \times \phi 3.75 \times \phi 1.7$	$\phi 8.3 \times \phi 4.5 \times \phi 1.9$	C4	C4
44	Side scraper	2	—	—	—	—	—	MYM50-15CK0502B	MYM63-15CK0503B
19	Scraper	2	MY1M16-PS	MY1M20-PS	MY1M25-PS	MY1M32-PS	MY1M40-PS	MY1M50-PS	MY1M63-PS
20	Piston seal	2							
21	Cushion seal	2							
22	Tube gasket	2							
39	O-ring	4							

* Seal kit includes 19, 20, 21, 22 and 39. Order the seal kit based on each bore size.

* Seal kit includes a grease pack (10 g).

When 16 and 17 are shipped independently, a grease pack is included. (10 g per 1000 strokes)

Order with the following part number when only the grease pack is needed.

Grease pack part number: GR-S-010 (10 g), **GR-S-020** (20 g)

Note) Two kinds of dust seal bands are available. Verify the type to use, since the part number varies depending on the treatment of the hexagon socket head set screw 33.

A: Black zinc chromated → MY□□-16B-stroke, B: Nickel plated → MY□□-16BW-stroke

MY1B

MY1M

MY1C

MY1H

MY1HT

MY1□W

MY2C

MY2H□

MY3A

MY3B

MY3M

D-□

-X□

Individual

-X□

Technical

data

Series MY1M

Standard Type/Centralized Piping Type $\phi 16, \phi 20$

Refer to page 1056 regarding centralized piping port variations.

MY1M16□/20□ — Stroke

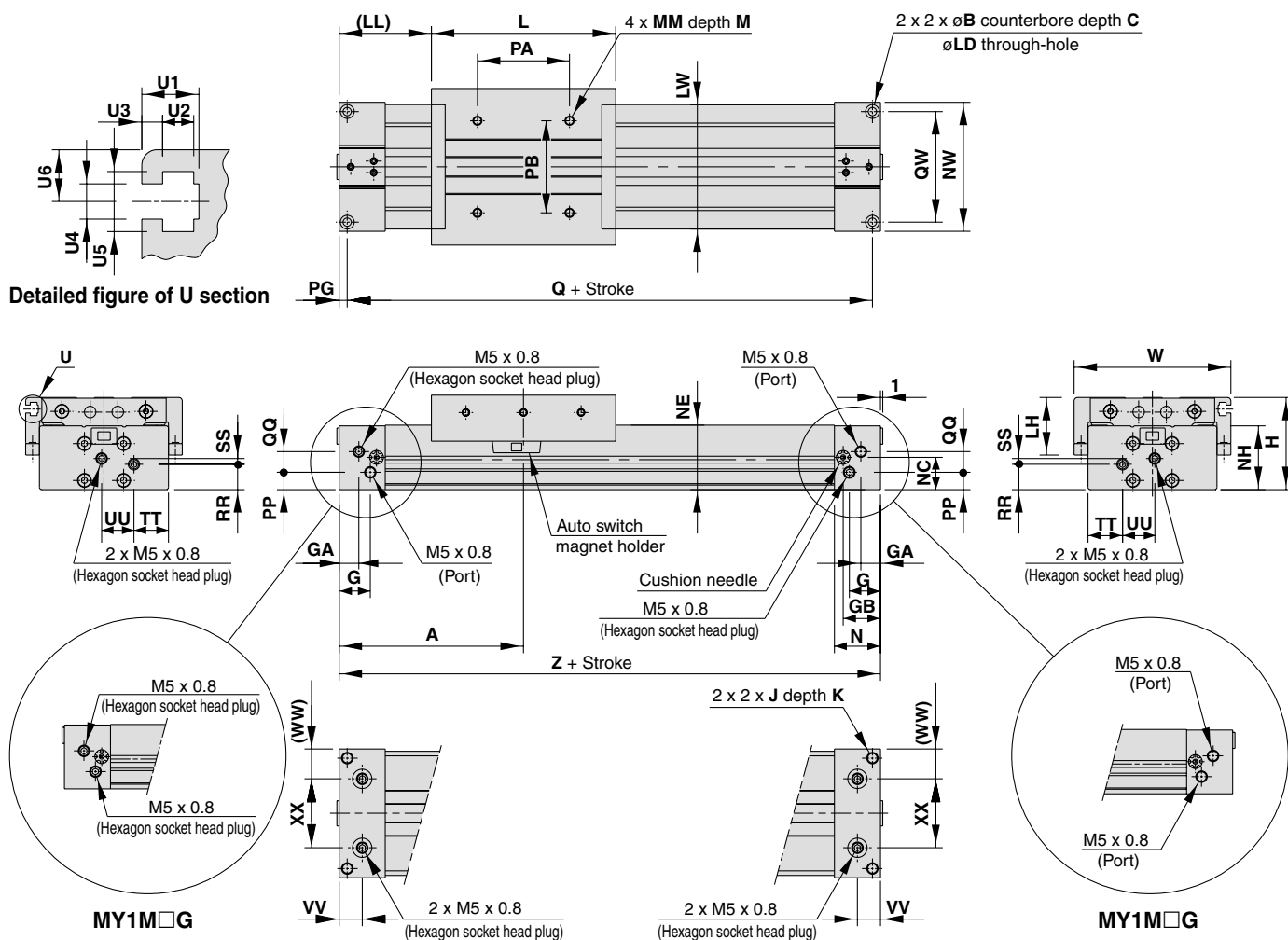

Model	A	B	C	G	GA	GB	H	J	K	L	LD	LH	LL	LW	M	MM	N	NC	NE	NH	NW	PA
MY1M16□	80	6	3.5	13.5	8.5	16.2	40	M5 x 0.8	10	80	3.6	22.5	40	54	6	M4 x 0.7	20	14	28	27.7	56	40
MY1M20□	100	7.5	4.5	12.5	12.5	20	46	M6 x 1	12	100	4.8	23	50	58	7.5	M5 x 0.8	25	17	34	33.7	60	50

Model	PB	PG	PP	Q	QQ	QW	RR	SS	TT	UU	VV	W	WW	XX	Z
MY1M16□	40	3.5	7.5	153	9	48	11	2.5	15	14	10	68	13	30	160
MY1M20□	40	4.5	11.5	191	10	45	14.5	5	18	12	12.5	72	14	32	200

Detailed Dimensions of U Section (mm)

Model	U1	U2	U3	U4	U5	U6
MY1M16□	5.5	3	2	3.4	5.8	5
MY1M20□	5.5	3	2	3.4	5.8	5.5

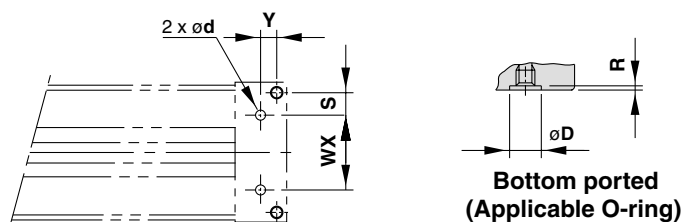

Hole Size for Centralized Piping on the Bottom

Model	WX	Y	S	d	D	R	Applicable O-ring
MY1M16□	30	6.5	9	4	8.4	1.1	C6
MY1M20□	32	8	6.5	4	8.4	1.1	

(Machine the mounting side to the dimensions below.)

Mechanically Jointed Rodless Cylinder Slide Bearing Guide Type **Series MY1M**

Standard Type/Centralized Piping Type $\phi 25, \phi 32, \phi 40$

Refer to page 1056 regarding centralized piping port variations.

MY1M25□/32□/40□ — Stroke

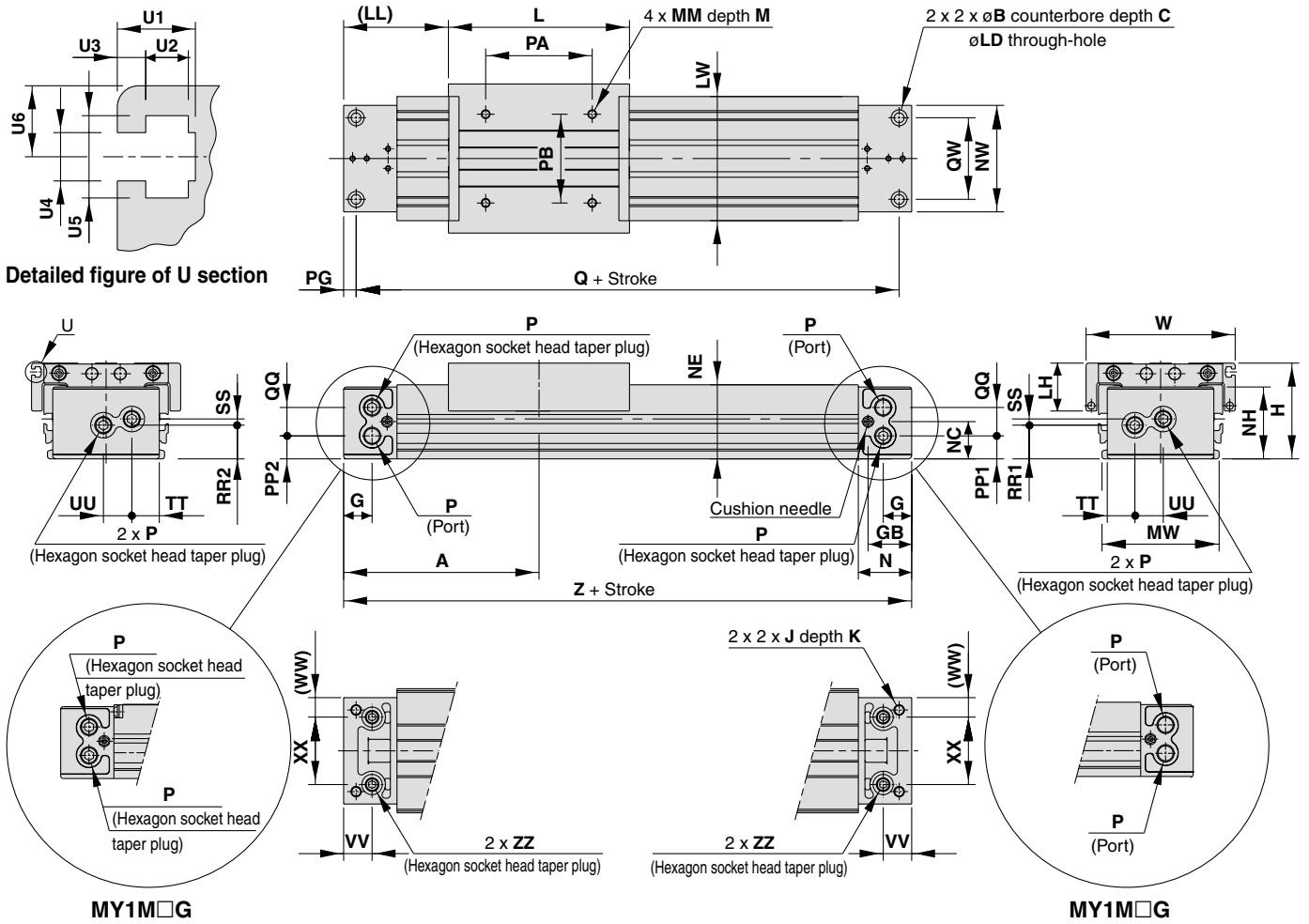

- MY1B
- MY1M
- MY1C
- MY1H
- MY1HT
- MY1□W
- MY2C
- MY2H□
- MY3A
- MY3B
- MY3M

Model	A	B	C	G	GB	H	J	K	L	LD	LH	LL	LW	M	MM	MW	N	NC	NE	NH	NW	P	PA
MY1M25□	110	9	5.5	17	24.5	54	M6 x 1	9.5	102	5.6	27	59	70	10	M5 x 0.8	66	30	21	41.8	40.5	60	Rc1/8	60
MY1M32□	140	11	6.5	19	30	68	M8 x 1.25	16	132	6.8	35	74	88	13	M6 x 1	80	37	26	52.3	50	74	Rc1/8	80
MY1M40□	170	14	8.5	23	36.5	84	M10 x 1.5	15	162	8.6	38	89	104	13	M6 x 1	96	45	32	65.3	63.5	94	Rc1/4	100

"P" indicates cylinder supply ports.

Detailed Dimensions of U Section

Model	PB	PG	PP1	PP2	Q	QQ	QW	RR1	RR2	SS	TT	UU	VV	W	WW	XX	Z	ZZ
MY1M25□	50	7	12.7	17.2	206	16	46	18.9	17.9	4.1	15.5	16	16	84	11	38	220	Rc 1/16
MY1M32□	60	8	15.5	18.5	264	16	60	22	24	4	21	16	19	102	13	48	280	Rc 1/16
MY1M40□	80	9	17.5	20	322	26	72	25.5	29	9	26	21	23	118	20	54	340	Rc 1/8

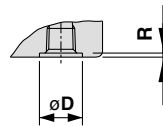
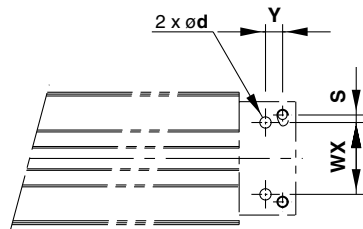

Bottom ported (ZZ)
(Applicable O-ring)

Hole Size for Centralized Piping on the Bottom

Model	WX	Y	S	d	D	R	Applicable O-ring
MY1M25□	38	9	4	6	11.4	1.1	C9
MY1M32□	48	11	6	6	11.4	1.1	
MY1M40□	54	14	9	8	13.4	1.1	

(Machine the mounting side to the dimensions below.)

- D-□
- X□
- Individual -X□
- Technical data

Series MY1M

Standard Type/Centralized Piping Type $\phi 50, \phi 63$

Refer to page 1056 regarding centralized piping port variations.

MY1M50□/60□ — Stroke

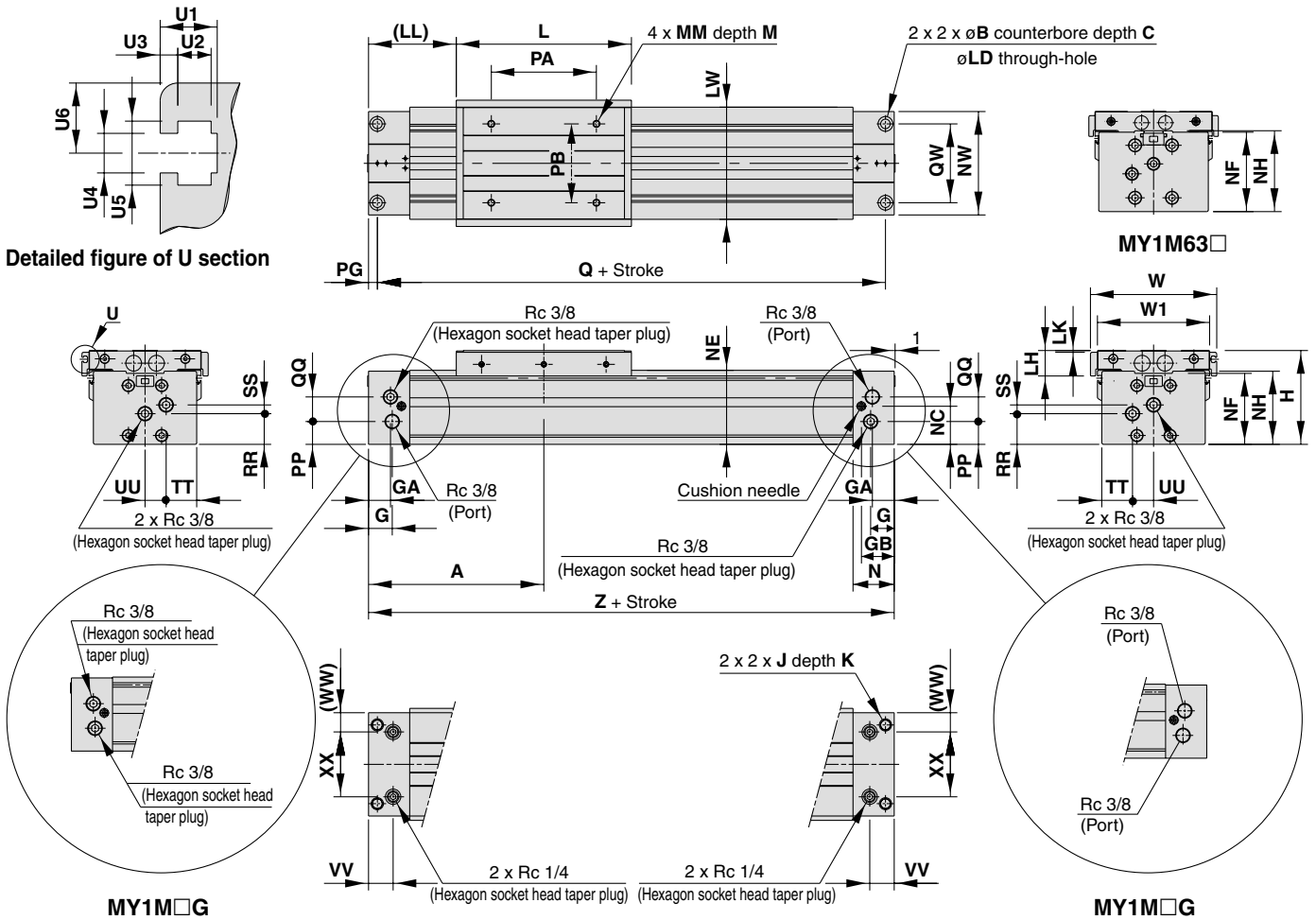

Model	A	B	C	G	GA	GB	H	J	K	L	LD	LH	LK	LL	LW	M	MM	N	NC	NE	NF	NH	NW	PA
MY1M50□	200	17	10.5	27	25	37.5	107	M14 x 2	28	200	11	29	2	100	128	15	M8 x 1.25	47	43.5	84.5	81	83.5	118	120
MY1M63□	230	19	12.5	29.5	27.5	39.5	130	M16 x 2	32	230	13.5	32.5	5.5	115	152	16	M10 x 1.5	50	56	104	103	105	142	140

Model	PB	PG	PP	Q	QQ	QW	RR	SS	TT	UU	VV	W	W1	WW	XX	Z
MY1M50□	90	10	26	380	28	90	35	10	35	24	28	144	128	22	74	400
MY1M63□	110	12	42	436	30	110	49	13	43	28	30	168	152	25	92	460

Detailed Dimensions of U Section

Model	U1	U2	U3	U4	U5	U6
MY1M50□	6.5	3.8	2	4.5	7.3	8
MY1M63□	8.5	5	2.5	5.5	8.4	8

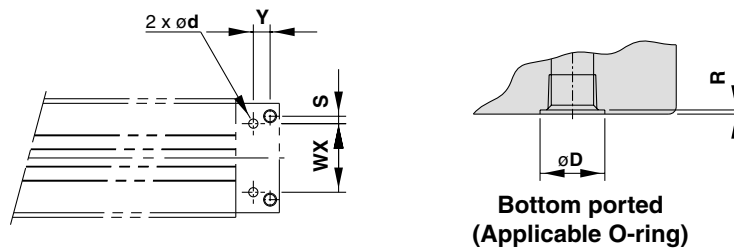

Hole Size for Centralized Piping on the Bottom

Model	WX	Y	S	d	D	R	Applicable O-ring
MY1M50□	74	18	8	10	17.5	1.1	C15
MY1M63□	92	18	9	10	17.5	1.1	

(Machine the mounting side to the dimensions below.)

Stroke Adjusting Unit

With adjusting bolt

MY1M Bore size — Stroke A

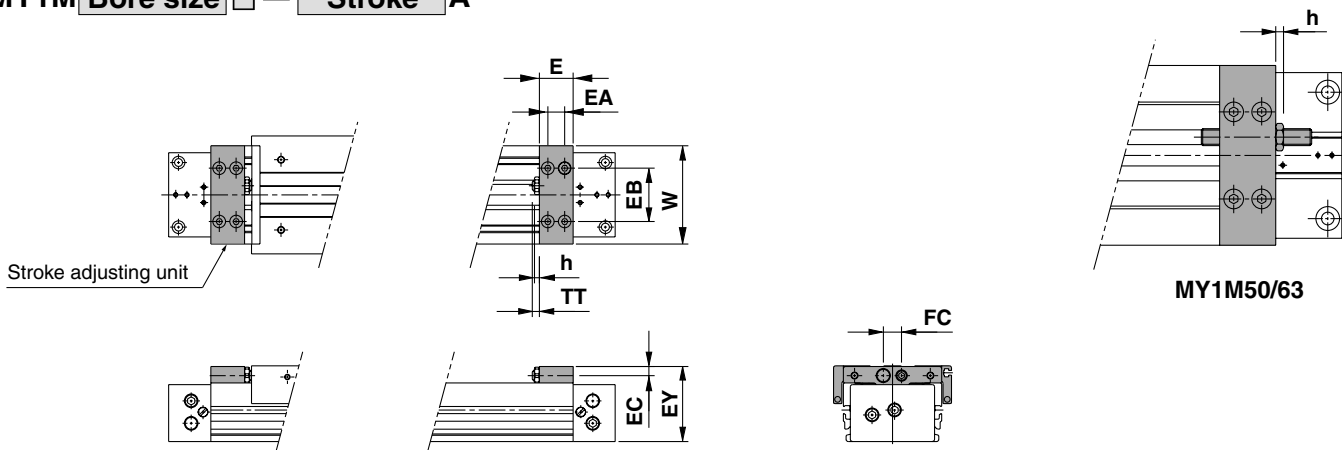

Applicable bore size	E	EA	EB	EC	EY	FC	h	TT	W
MY1M16	14.6	7	30	5.8	39.5	14	3.6	5.4 (Max. 11)	58
MY1M20	20	10	32	5.8	45.5	14	3.6	5 (Max. 11)	58
MY1M25	24	12	38	6.5	53.5	13	3.5	5 (Max. 16.5)	70
MY1M32	29	14	50	8.5	67	17	4.5	8 (Max. 20)	88
MY1M40	35	17	57	10	83	17	4.5	9 (Max. 25)	104
MY1M50	40	20	66	14	106	26	5.5	13 (Max. 33)	128
MY1M63	52	26	77	14	129	31	5.5	13 (Max. 38)	152

- MY1B
- MY1M
- MY1C
- MY1H
- MY1HT
- MY1□W
- MY2C
- MY2H□
- MY3A
- MY3B
- MY3M

With low load shock absorber + Adjusting bolt

MY1M Bore size — Stroke L

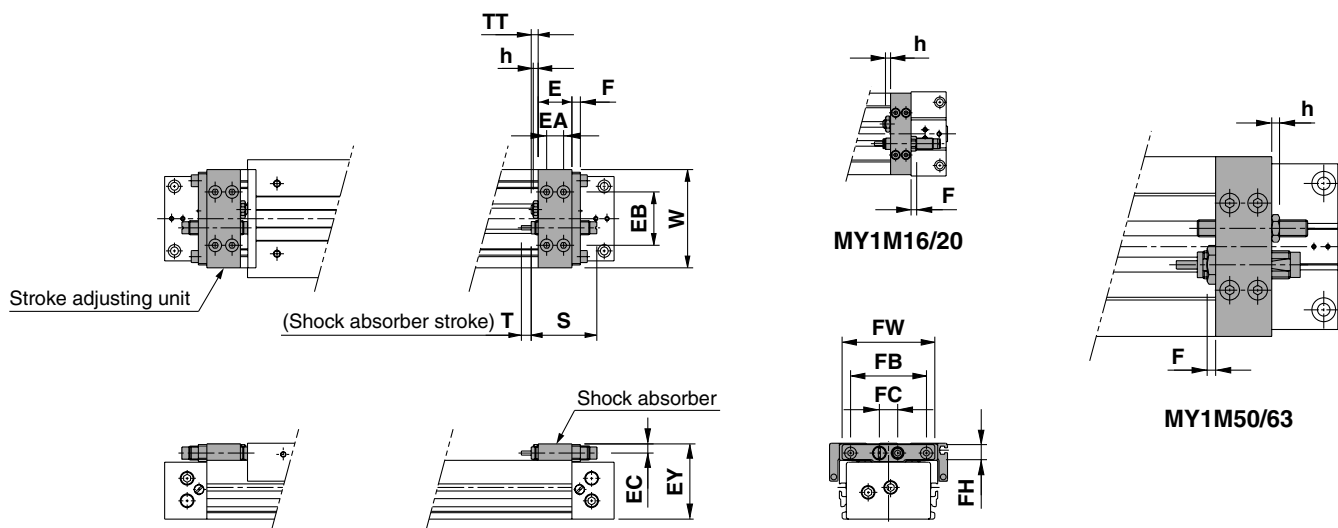

Applicable bore size	E	EA	EB	EC	EY	F	FB	FC	FH	FW	h	S	T	TT	W	Shock absorber model
MY1M16	14.6	7	30	5.8	39.5	4	—	14	—	—	3.6	40.8	6	5.4 (Max. 11)	58	RB0806
MY1M20	20	10	32	5.8	45.5	4	—	14	—	—	3.6	40.8	6	5 (Max. 11)	58	RB0806
MY1M25	24	12	38	6.5	53.5	6	54	13	13	66	3.5	46.7	7	5 (Max. 16.5)	70	RB1007
MY1M32	29	14	50	8.5	67	6	67	17	16	80	4.5	67.3	12	8 (Max. 20)	88	RB1412
MY1M40	35	17	57	10	83	6	78	17	17.5	91	4.5	67.3	12	9 (Max. 25)	104	RB1412
MY1M50	40	20	66	14	106	6	—	26	—	—	5.5	73.2	15	13 (Max. 33)	128	RB2015
MY1M63	52	26	77	14	129	6	—	31	—	—	5.5	73.2	15	13 (Max. 38)	152	RB2015

- D-□
- X□
- Individual -X□
- Technical data

Series MY1M

Stroke Adjusting Unit

With high load shock absorber + Adjusting bolt

MY1M Bore size — Stroke H

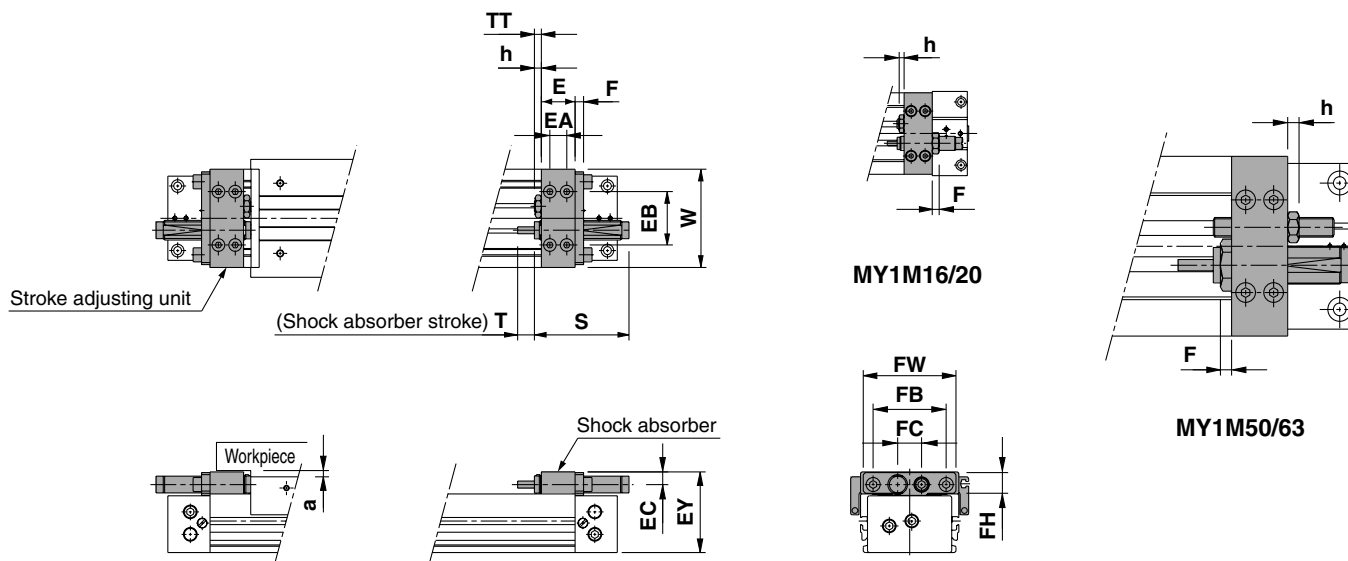

* Since dimension EY of the H type unit is greater than the table top height (dimension H), when mounting a workpiece that exceeds the overall length (dimension L) of the slide table, allow a clearance of dimension "a" or larger on the workpiece side.

Applicable bore size	E	EA	EB	EC	EY	F	FB	FC	FH	FW	h	S	T	TT	W	Shock absorber model	a
MY1M20	20	10	32	7.7	50	5	—	14	—	—	3.5	46.7	7	5 (Max. 11)	58	RB1007	5
MY1M25	24	12	38	9	57.5	6	52	17	16	66	4.5	67.3	12	5 (Max. 16.5)	70	RB1412	4.5
MY1M32	29	14	50	11.5	73	8	67	22	22	82	5.5	73.2	15	8 (Max. 20)	88	RB2015	6
MY1M40	35	17	57	12	87	8	78	22	22	95	5.5	73.2	15	9 (Max. 25)	104	RB2015	4
MY1M50	40	20	66	18.5	115	8	—	30	—	—	11	99	25	13 (Max. 33)	128	RB2725	9
MY1M63	52	26	77	19	138.5	8	—	35	—	—	11	99	25	13 (Max. 38)	152	RB2725	9.5

Side Support

Side support A MY-S□A

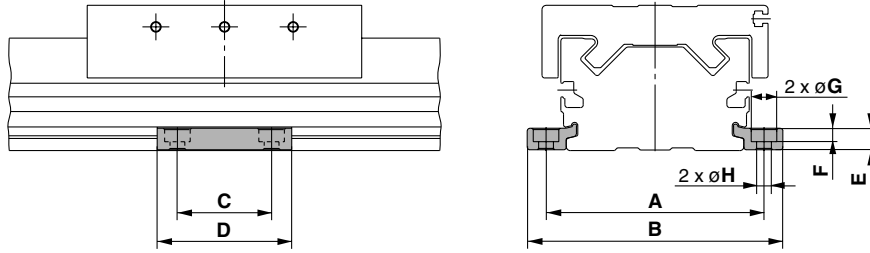

Side support B MY-S□B

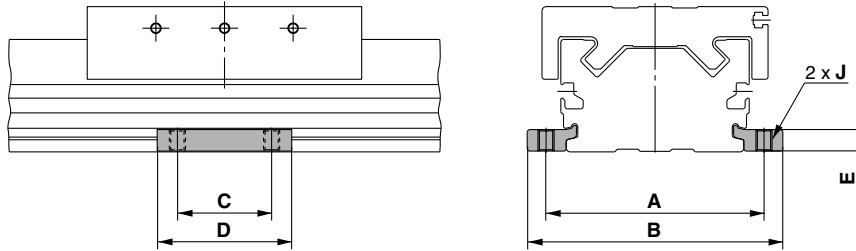

Model	Applicable bore size	A	B	C	D	E	F	G	H	J
MY-S16 ^A _B	MY1M16	61	71.6	15	26	4.9	3	6.5	3.4	M4 x 0.7
MY-S20 ^A _B	MY1M20	67	79.6	25	38	6.4	4	8	4.5	M5 x 0.8
MY-S25 ^A _B	MY1M25	81	95	35	50	8	5	9.5	5.5	M6 x 1
MY-S32 ^A _B	MY1M32	100	118	45	64	11.7	6	11	6.6	M8 x 1.25
MY-S40 ^A _B	MY1M40	120	142	55	80	14.8	8.5	14	9	M10 x 1.5
	MY1M50	142	164							
MY-S63 ^A _B	MY1M63	172	202	70	100	18.3	10.5	17.5	11.5	M12 x 1.75

* A set of side supports consists of a left support and a right support.

Guide for Side Support Application

For long stroke operation, the cylinder tube may be deflected depending on its own mass and the load mass. In such a case, use a side support in the middle section. The spacing (l) of the support must be no more than the values shown in the graph on the right.

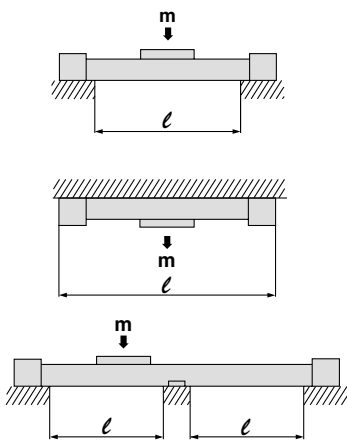

Caution

1. If the cylinder mounting surfaces are not measured accurately, using a side support may cause poor operation. Therefore, be sure to level the cylinder tube when mounting. Also, for long stroke operation involving vibration and impact, use of a side support is recommended even if the spacing value is within the allowable limits shown in the graph.
2. Support brackets are not for mounting; use them solely for providing support.

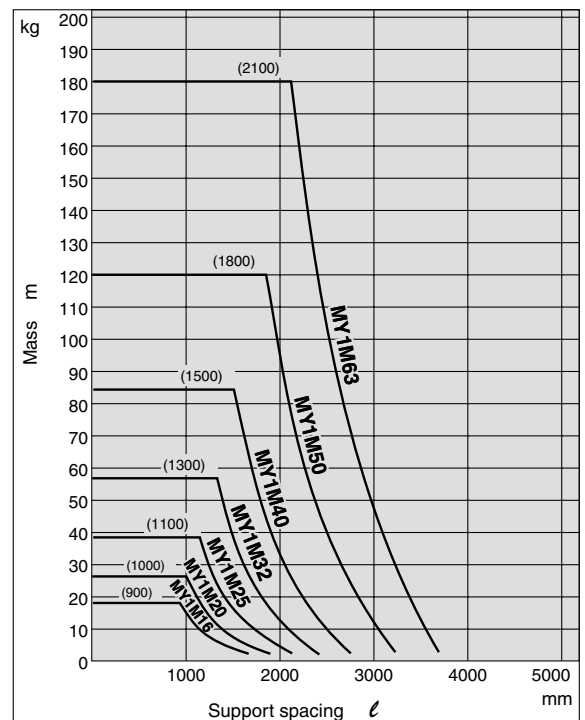

MY1B

MY1M

MY1C

MY1H

MY1HT

MY1□W

MY2C

MY2H□

MY3A

MY3B

MY3M

D-□

-X□

Individual

-X□

Technical

data

Series MY1C

Cam Follower Guide Type

ø16, ø20, ø25, ø32, ø40, ø50, ø63

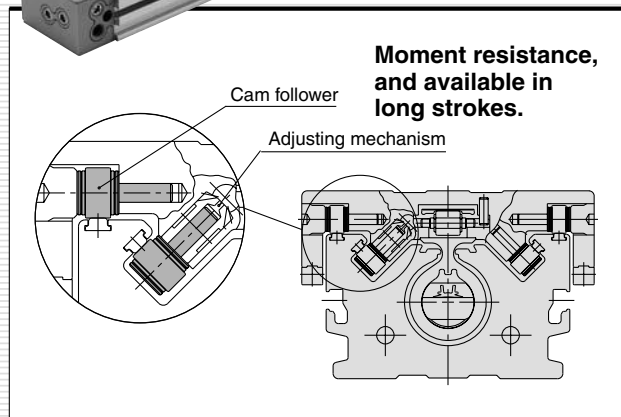
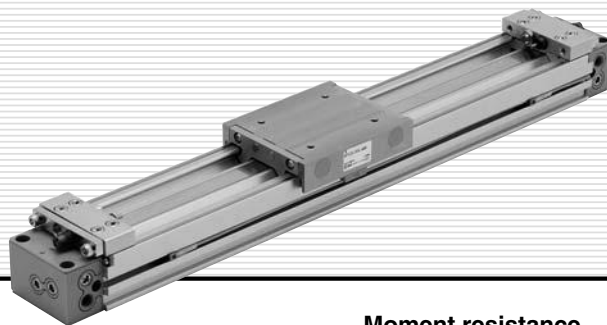

MY1B

MY1M

MY1C

MY1H

MY1HT

MY1□W

MY2C

MY2H□

MY3A
MY3B

MY3M

D-□

-X□

Individual
-X□

Technical
data

Series MY1C Prior to Use

Maximum Allowable Moment/Maximum Load Mass

Model	Bore size (mm)	Maximum allowable moment (N·m)			Maximum load mass (kg)		
		M ₁	M ₂	M ₃	m ₁	m ₂	m ₃
MY1C	16	6.0	3.0	2.0	18	7	2.1
	20	10	5.0	3.0	25	10	3
	25	15	8.5	5.0	35	14	4.2
	32	30	14	10	49	21	6
	40	60	23	20	68	30	8.2
	50	115	35	35	93	42	11.5
	63	150	50	50	130	60	16

The above values are the maximum allowable values for moment and load. Refer to each graph regarding the maximum allowable moment and maximum allowable load for a particular piston speed.

Load mass (kg)

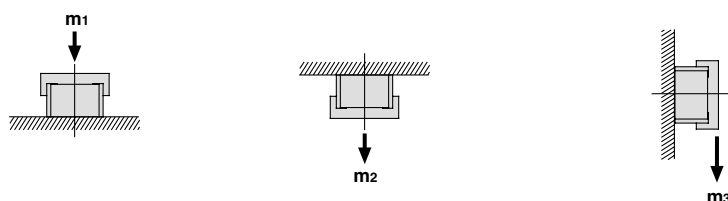

Moment (N·m)

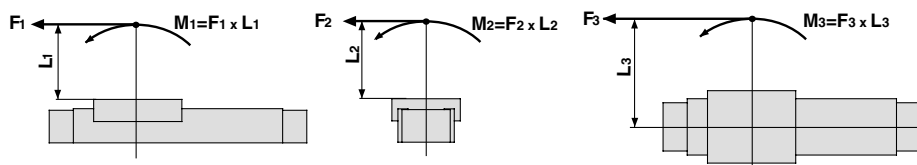

<Calculation of guide load factor>

- Maximum allowable load (1), static moment (2), and dynamic moment (3) (at the time of impact with stopper) must be examined for the selection calculations.
 - * To evaluate, use \bar{v} (average speed) for (1) and (2), and v (collision speed $v = 1.4\bar{v}$) for (3). Calculate m_{max} for (1) from the maximum allowable load graph (m_1, m_2, m_3) and M_{max} for (2) and (3) from the maximum allowable moment graph (M_1, M_2, M_3).

$$\text{Sum of guide load factors } \Sigma\alpha = \frac{\text{Load mass [m]}}{\text{Maximum allowable load [m}_{max}\text{]}} + \frac{\text{Static moment [M]}^{(1)}}{\text{Allowable static moment [M}_{max}\text{]}} + \frac{\text{Dynamic moment [M}_E\text{]}^{(2)}}{\text{Allowable dynamic moment [M}_{Emax}\text{]}} \leq 1$$

Note 1) Moment caused by the load, etc., with cylinder in resting condition.

Note 2) Moment caused by the impact load equivalent at the stroke end (at the time of impact with stopper).

Note 3) Depending on the shape of the workpiece, multiple moments may occur. When this happens, the sum of the load factors ($\Sigma\alpha$) is the total of all such moments.

2. Reference formula [Dynamic moment at impact]

Use the following formulae to calculate dynamic moment when taking stopper impact into consideration.

- m**: Load mass (kg)
- F**: Load (N)
- F_E**: Load equivalent to impact (at impact with stopper) (N)
- \bar{v}** : Average speed (mm/s)
- M**: Static moment (N·m)
- v** : Collision speed (mm/s)
- L₁**: Distance to the load's center of gravity (m)
- M_E**: Dynamic moment (N·m)
- δ** : Damper coefficient
 - At collision: $v = 1.4\bar{v}$
 - With rubber bumper = 4/100 (MY1B10, MY1H10)
 - With air cushion = 1/100
 - With shock absorber = 1/100
- g**: Gravitational acceleration (9.8 m/s²)

$$v = 1.4\bar{v} \text{ (mm/s)} \quad F_E = 1.4\bar{v} \cdot \delta \cdot m \cdot g$$

$$\therefore M_E = \frac{1}{3} \cdot F_E \cdot L_1 = 4.57\bar{v} \delta m L_1 \text{ (N·m)}$$

Note 4) $1.4\bar{v}\delta$ is a dimensionless coefficient for calculating impact force.

Note 5) Average load coefficient ($= \frac{1}{3}$): This coefficient is for averaging the maximum load moment at the time of stopper impact according to service life calculations.

3. For detailed selection procedures, refer to pages 998 and 999.

Maximum Allowable Moment

Select the moment from within the range of operating limits shown in the graphs. Note that the maximum allowable load value may sometimes be exceeded even within the operating limits shown in the graphs. Therefore, also check the allowable load for the selected conditions.

Maximum Load Mass

Select the load from within the range of limits shown in the graphs. Note that the maximum allowable moment value may sometimes be exceeded even within the operating limits shown in the graphs. Therefore, also check the allowable moment for the selected conditions.

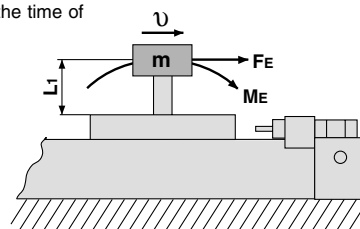

MY1C/M₁

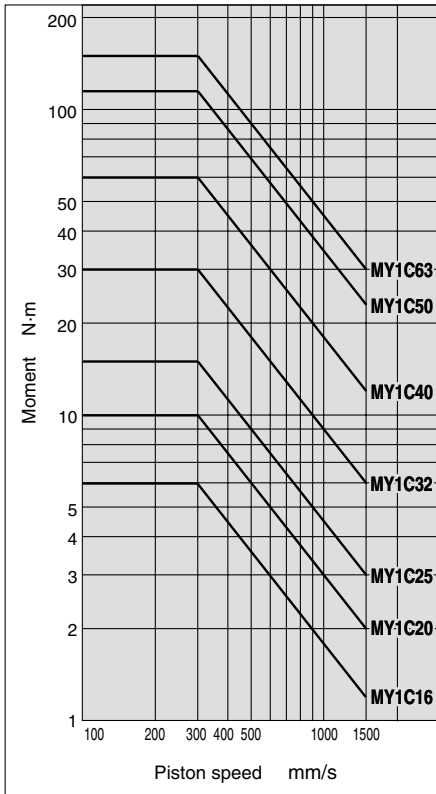

MY1C/M₂

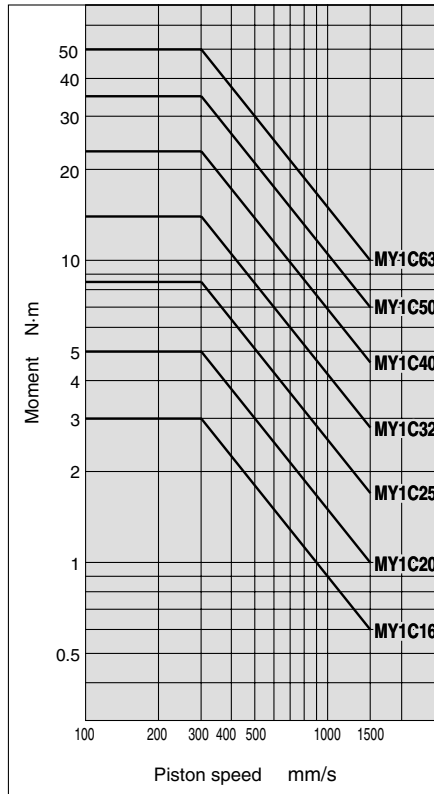

MY1C/M₃

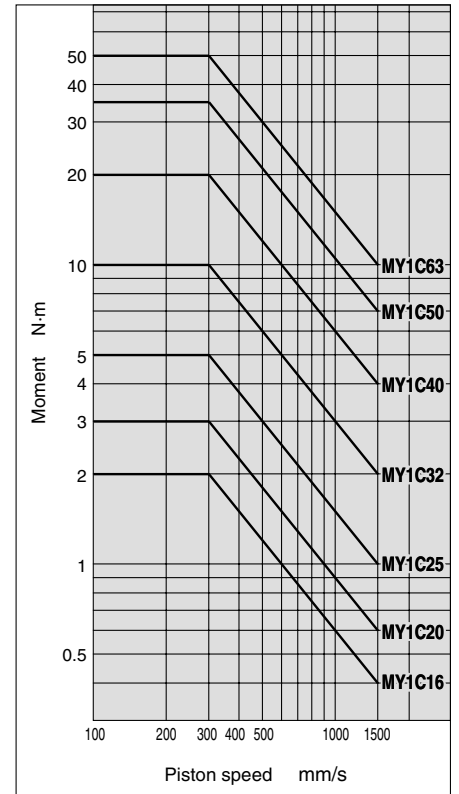

- MY1B
- MY1M
- MY1C**
- MY1H
- MY1HT
- MY1□W
- MY2C
- MY2H□
- MY3A
- MY3B
- MY3M

MY1C/m₁

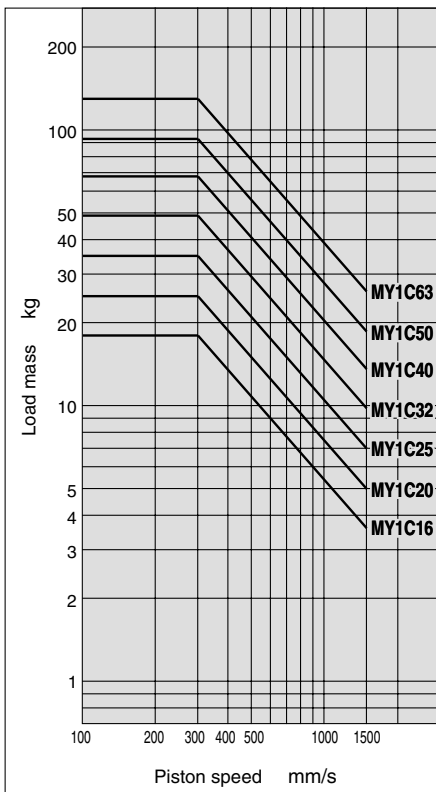

MY1C/m₂

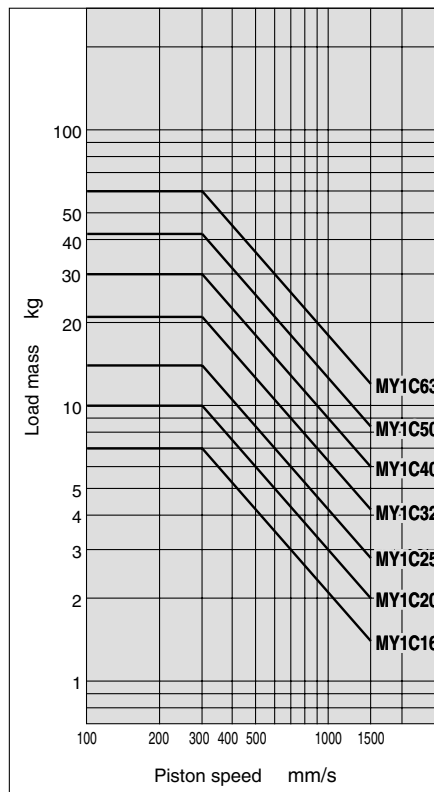

MY1C/m₃

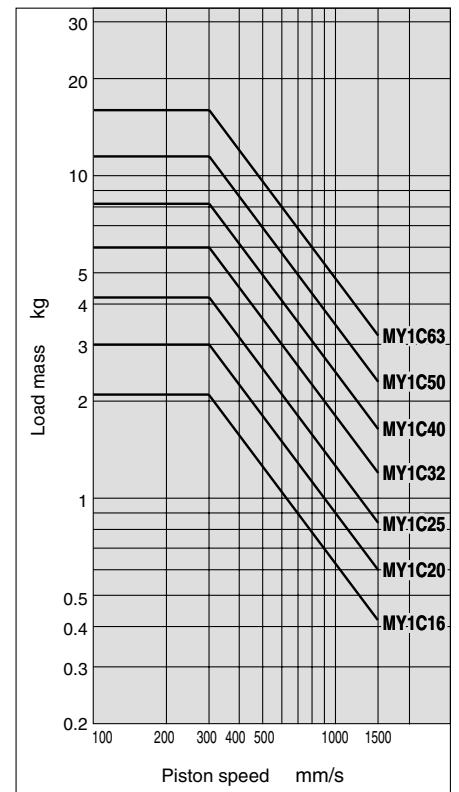

- D-□
- X□
- Individual
- X□
- Technical data

Series MY1C Model Selection

Following are the steps for selecting the most suitable Series MY1C to your application.

Calculation of Guide Load Factor

1. Operating Conditions

Cylinder..... MY1C40-500
Average operating speed v_a ... 300 mm/s
Mounting orientation..... Ceiling mounting
Cushion..... Air cushion
($\delta = 1/100$)

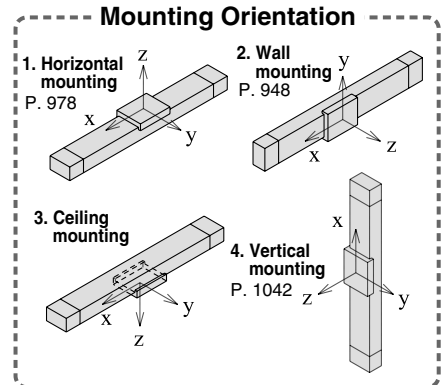
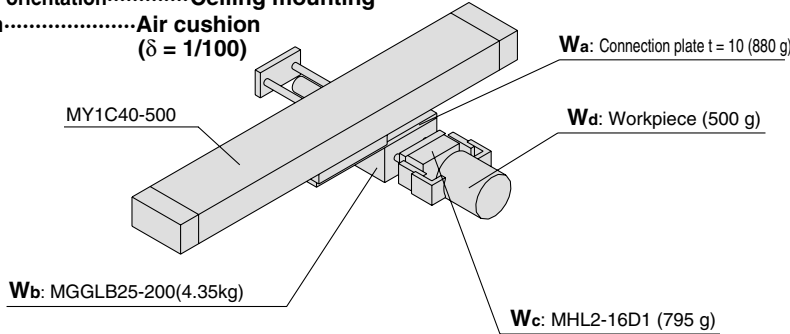

For actual examples of calculation for each orientation, refer to the pages above.

2. Load Blocking

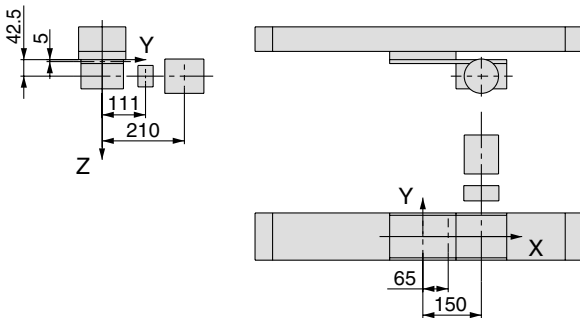

Mass and Center of Gravity for Each Workpiece

Workpiece no. W_n	Mass m_n	Center of gravity		
		X-axis X_n	Y-axis Y_n	Z-axis Z_n
Wa	0.88 kg	65 mm	0 mm	5 mm
Wb	4.35 kg	150 mm	0 mm	42.5 mm
Wc	0.795 kg	150 mm	111 mm	42.5 mm
Wd	0.5 kg	150 mm	210 mm	42.5 mm

n=a, b, c, d

3. Composite Center of Gravity Calculation

$$m_2 = \sum m_n$$

$$= 0.88 + 4.35 + 0.795 + 0.5 = \mathbf{6.525 \text{ kg}}$$

$$X = \frac{1}{m_2} \times \sum (m_n \times X_n)$$

$$= \frac{1}{6.525} (0.88 \times 65 + 4.35 \times 150 + 0.795 \times 150 + 0.5 \times 150) = \mathbf{138.5 \text{ mm}}$$

$$Y = \frac{1}{m_2} \times \sum (m_n \times Y_n)$$

$$= \frac{1}{6.525} (0.88 \times 0 + 4.35 \times 0 + 0.795 \times 111 + 0.5 \times 210) = \mathbf{29.6 \text{ mm}}$$

$$Z = \frac{1}{m_2} \times \sum (m_n \times Z_n)$$

$$= \frac{1}{6.525} (0.88 \times 5 + 4.35 \times 42.5 + 0.795 \times 42.5 + 0.5 \times 42.5) = \mathbf{37.4 \text{ mm}}$$

4. Calculation of Load Factor for Static Load

m_2 : Mass

$m_2 \text{ max}$ (from (1) of graph MY1C/ m_2) = 30 (kg).....

Load factor $\alpha_1 = m_2/m_2 \text{ max} = 6.525/30 = \mathbf{0.22}$

M_1 : Moment

$M_1 \text{ max}$ (from (2) of graph MY1C/ M_1) = 60 (N·m).....

$M_1 = m_2 \times g \times X = 6.525 \times 9.8 \times 138.5 \times 10^{-3} = 8.86 \text{ (N·m)}$

Load factor $\alpha_2 = M_1/M_1 \text{ max} = 8.86/60 = \mathbf{0.15}$

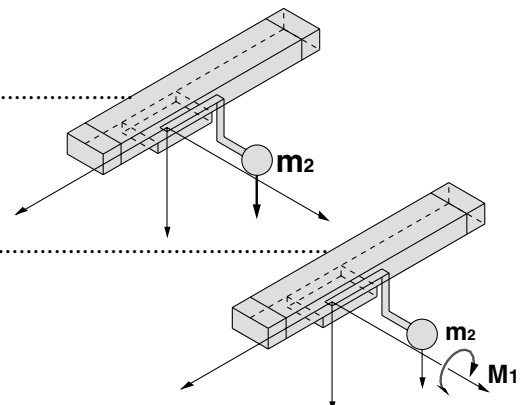

M₂: Moment

M₂ max (from (3) of graph MY1C/M₂) = 23.0 (N·m).....

M₂ = **m₂** × **g** × **Y** = 6.525 × 9.8 × 29.6 × 10⁻³ = 1.89 (N·m)

Load factor **α₃** = **M₂**/M₂ max = 1.89/23.0 = **0.08**

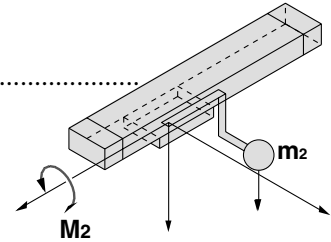

5. Calculation of Load Factor for Dynamic Moment

Equivalent load F_E at impact

F_E = 1.4v_a × δ × m × g = 1.4 × 300 × $\frac{1}{100}$ × 6.525 × 9.8 = 268.6 (N)

M_{1E}: Moment

M_{1E} max (from (4) of graph MY1C/M₁ where 1.4v_a = 420 mm/s) = 42.9 (N·m).....

M_{1E} = $\frac{1}{3}$ × F_E × Z = $\frac{1}{3}$ × 268.6 × 37.4 × 10⁻³ = 3.35 (N·m)

Load factor **α₄** = **M_{1E}**/M_{1E} max = 3.35/42.9 = **0.08**

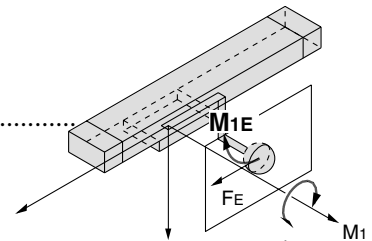

M_{3E}: Moment

M_{3E} max (from (5) of graph MY1C/M₃ where 1.4v_a = 420 mm/s) = 14.3 (N·m).....

M_{3E} = $\frac{1}{3}$ × F_E × Y = $\frac{1}{3}$ × 268.6 × 29.6 × 10⁻³ = 2.65 (N·m)

Load factor **α₅** = **M_{3E}**/M_{3E} max = 2.65/14.3 = **0.19**

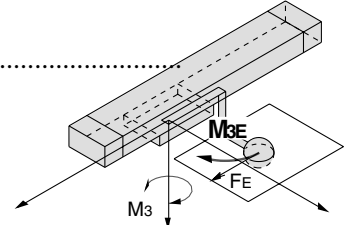

6. Sum and Examination of Guide Load Factors

$\Sigma\alpha = \alpha_1 + \alpha_2 + \alpha_3 + \alpha_4 + \alpha_5 = 0.72 \leq 1$

The above calculation is within the allowable value, and therefore the selected model can be used.

Select a shock absorber separately.

In an actual calculation, when the total sum of guide load factors $\Sigma\alpha$ in the formula above is more than 1, consider either decreasing the speed, increasing the bore size, or changing the product series. This calculation can be easily made using the "SMC Pneumatics CAD System".

Load Mass

MY1C/m₂

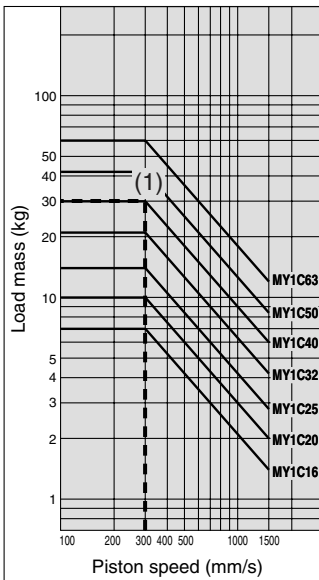

Allowable Moment

MY1C/M₁

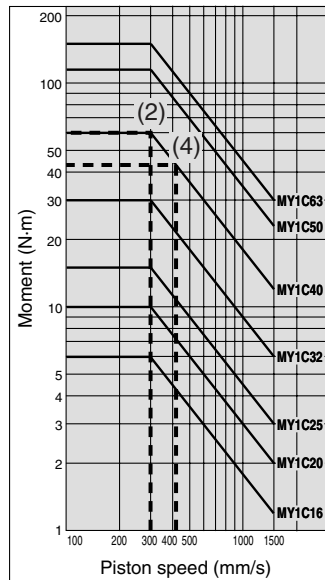

MY1C/M₂

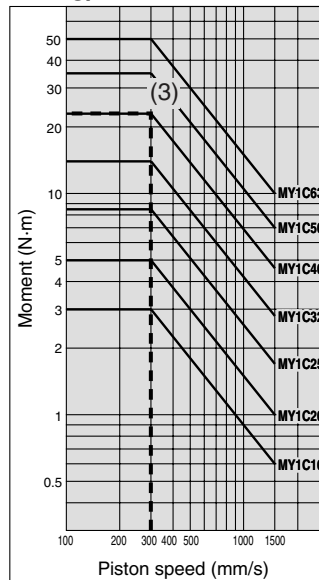

MY1C/M₃

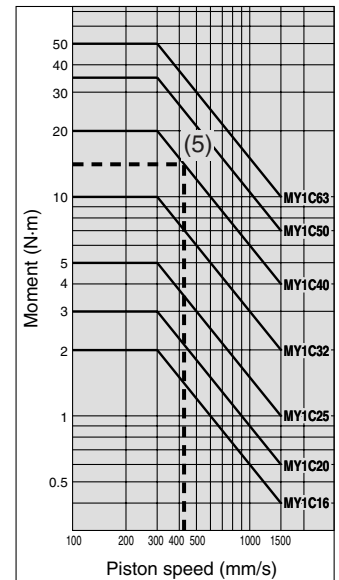

MY1B

MY1M

MY1C

MY1H

MY1HT

MY1□W

MY2C

MY2H□

MY3A

MY3B

MY3M

D-□

-X□

Individual

-X□

Technical

data

Mechanically Jointed Rodless Cylinder Cam Follower Guide Type

Series MY1C

ø16, ø20, ø25, ø32, ø40, ø50, ø63

How to Order

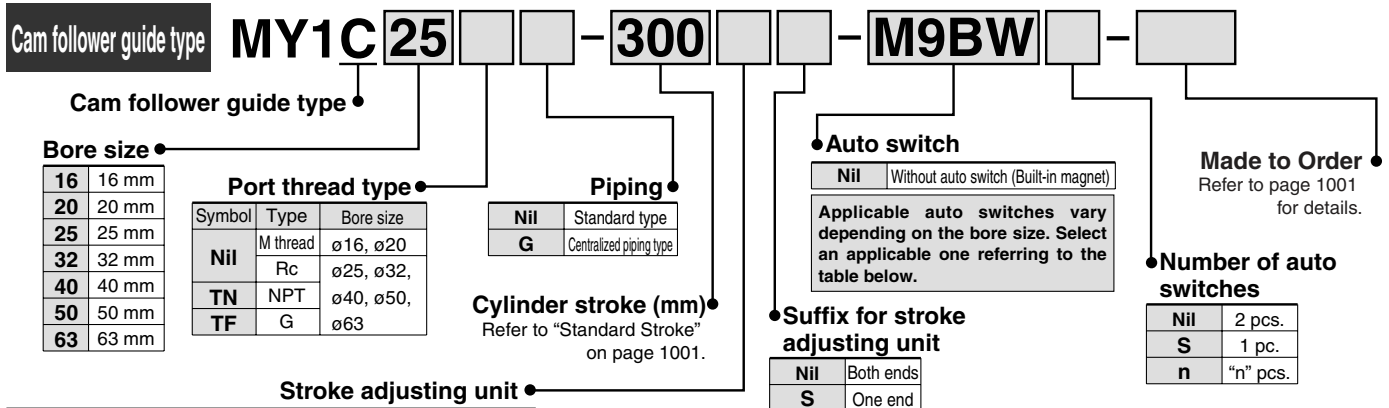

Shock Absorbers for L and H Units

Unit no.	Bore size (mm)	16	20	25	32	40	50	63
L unit		RB0806		RB1007		RB1412		RB2015
H unit		—	RB1007	RB1412		RB2015		RB2725

Note) MY1C16 is not available with H unit.

Applicable Auto Switch

Refer to pages 1263 to 1371 for further information on auto switches.

Type	Special function	Electrical entry	Indicator light	Wiring (Output)	Load voltage			Auto switch model				Lead wire length (m)				Pre-wired connector	Applicable load	
					DC	AC	Perpendicular		In-line		0.5 (Nil)	1 (M)	3 (L)	5 (Z)				
							ø16, ø20	ø25 to ø63	ø16, ø20	ø25 to ø63								
Solid state switch	—	Grommet	Yes	3-wire (NPN)	24V	5V, 12V	—	M9NV**	M9N**	●	●	●	○	○	IC circuit	Relay, PLC		
								[Y69A]	[Y59A]	○	○	○	○					
								M9PV**	M9P**	●	●	○	○					
	[Y7PV]			[Y7P]	○	○	○	○										
	2-wire			5V, 12V	—	M9BV**	M9B**	●	●	○	○	—						
	[Y69B]					[Y59B]	○	○										
M9NWV**	M9NW**	●	●			○	○											
[Y7NWV]	[Y7NW]	○	○	IC circuit														
3-wire (NPN)	24V	5V, 12V	—		M9PWV**	M9PW**	●	●	○	○								
[Y7PWV]					[Y7PW]	○	○											
3-wire (PNP)				M9BWV**	M9BW**	●	●	○	○									
[Y7BWV]	[Y7BW]	○	○	—														
2-wire	24V	12V	100V		100V or less	A96V	—	A96	Z76	●	—	●	—	IC circuit				
3-wire (NPN equivalent)						A93V	—	A93	—	●	—	●	—		—			
				—		—	—	Z73	●	—	●	—						
Reed switch	—	Grommet	Yes	2-wire	24V	12V	100V	100V or less	A90V	—	A90	Z80	●	—	●	—	IC circuit	
									—	—	—	—	●	—	●	—		

* Lead wire length symbols: 0.5 m Nil (Example) M9NW
 1 m M (Example) M9NWM
 3 m L (Example) M9NWL
 5 m Z (Example) M9NWZ

* Solid state auto switches marked with "○" are produced upon receipt of order.
 ** D-M9□□□ type cannot be mounted on ø40.
 Select auto switches in brackets.

* There are other applicable auto switches than listed above. For details, refer to page 1053.
 * For details about auto switches with pre-wired connector, refer to pages 1328 and 1329.
 * Auto switches are shipped together (not assembled).

Mechanically Jointed Rodless Cylinder Cam Follower Guide Type *Series MY1C*



JIS Symbol

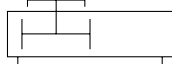

Specifications

Bore size (mm)	16	20	25	32	40	50	63
Fluid	Air						
Action	Double acting						
Operating pressure range	0.1 to 0.8 MPa						
Proof pressure	1.2 MPa						
Ambient and fluid temperature	5 to 60°C						
Cushion	Air cushion						
Lubrication	Non-lube						
Stroke length tolerance	1000 or less $\begin{smallmatrix} +1.8 \\ 0 \\ -2.8 \end{smallmatrix}$		2700 or less $\begin{smallmatrix} +1.8 \\ 0 \\ -2.8 \end{smallmatrix}$, 2701 to 5000 $\begin{smallmatrix} +2.8 \\ 0 \end{smallmatrix}$				
Piping port size	Front/Side port	M5 x 0.8		Rc 1/8		Rc 1/4	Rc 3/8
	Bottom port	ø4		ø5	ø6	ø8	ø10

Stroke Adjusting Unit Specifications

Bore size (mm)	16			20			25			32			40			50			63														
Unit symbol	A	L	H	A	L	H	A	L	H	A	L	H	A	L	H	A	L	H															
Configuration Shock absorber model	With adjusting bolt RB 0806 + with adjusting bolt			With adjusting bolt RB 0806 + with adjusting bolt			With adjusting bolt RB 1007 + with adjusting bolt			With adjusting bolt RB 1007 + with adjusting bolt			With adjusting bolt RB 1412 + with adjusting bolt			With adjusting bolt RB 2015 + with adjusting bolt			With adjusting bolt RB 1412 + with adjusting bolt			With adjusting bolt RB 2015 + with adjusting bolt			With adjusting bolt RB 2725 + with adjusting bolt			With adjusting bolt RB 2015 + with adjusting bolt			With adjusting bolt RB 2725 + with adjusting bolt		
Fine stroke adjustment range (mm)	0 to -5.6			0 to -6			0 to -11.5			0 to -12			0 to -16			0 to -20			0 to -25														
Stroke adjustment range	When exceeding the stroke fine adjustment range: Utilize a made-to-order specifications "-X416" and "-X417".																																

* Stroke adjustment range is applicable for one side when mounted on a cylinder.

Shock Absorber Specifications

Model	RB 0806	RB 1007	RB 1412	RB 2015	RB 2725	
Max. energy absorption (J)	2.9	5.9	19.6	58.8	147	
Stroke absorption (mm)	6	7	12	15	25	
Max. collision speed (mm/s)	1500					
Max. operating frequency (cycle/min)	80	70	45	25	10	
Spring force (N)	Extended	1.96	4.22	6.86	8.34	8.83
	Retracted	4.22	6.86	15.98	20.50	20.01
Operating temperature range (°C)	5 to 60					

The shock absorber service life is different from that of the MY1C cylinder depending on operating conditions. Refer to the RB Series Specific Product Precautions for the replacement period.



Made to Order Specifications
(For details, refer to pages 1395 to 1565.)

Symbol	Specifications
-XB11	Long stroke
-XC56	With knock pin hole
-XC67	NBR rubber lining in dust seal band
-X168	Helical insert thread specifications
-X416	Holder mounting bracket I
-X417	Holder mounting bracket II

Standard Stroke

Bore size (mm)	Standard stroke (mm) *	Maximum manufacturable stroke (mm)
16	100, 200, 300, 400, 500, 600, 700	3000
20, 25, 32, 40, 50, 63	800, 900, 1000, 1200, 1400, 1600, 1800, 2000	5000

* Strokes are manufacturable in 1 mm increments, up to the maximum stroke. However, when exceeding a 2000 mm stroke, specify "-XB11" at the end of the model number.

Piston Speed

Bore size (mm)	16 to 63	
Without stroke adjusting unit	100 to 1000 mm/s	
Stroke adjusting unit	A unit	100 to 1000 mm/s ⁽¹⁾
	L unit and H unit	100 to 1500 mm/s ⁽²⁾

Note 1) Be aware that when the stroke adjusting range is increased by manipulating the adjusting bolt, the air cushion capacity decreases. Also, when exceeding the air cushion stroke ranges on page 1004, **the piston speed should be 100 to 200 mm per second.**

Note 2) The piston speed is 100 to 1000 mm/s for centralized piping.

Note 3) Use at a speed within the absorption capacity range. Refer to page 1004.

MY1B

MY1M

MY1C

MY1H

MY1HT

MY1□W

MY2C

MY2H□

MY3A

MY3B

MY3M

D-□

-X□

Individual
-X□

Technical
data

Series MY1C

Theoretical Output

Bore size (mm)	Piston area (mm ²)	Operating pressure (MPa)						
		0.2	0.3	0.4	0.5	0.6	0.7	0.8
16	200	40	60	80	100	120	140	160
20	314	62	94	125	157	188	219	251
25	490	98	147	196	245	294	343	392
32	804	161	241	322	402	483	563	643
40	1256	251	377	502	628	754	879	1005
50	1962	392	588	784	981	1177	1373	1569
63	3115	623	934	1246	1557	1869	2180	2492

(N)
Note) Theoretical output (N) = Pressure (MPa) x Piston area (mm²)

Mass

Bore size (mm)	Basic mass	Additional mass per each 50mm of stroke	Side support mass (per set)	Stroke adjusting unit mass (per unit)		
			Type A and B	A unit mass	L unit mass	H unit mass
16	0.67	0.12	0.01	0.03	0.04	—
20	1.06	0.15	0.02	0.04	0.05	0.08
25	1.58	0.24	0.02	0.07	0.11	0.18
32	3.14	0.37	0.04	0.14	0.23	0.39
40	5.60	0.52	0.08	0.25	0.34	0.48
50	10.14	0.76	0.08	0.36	0.51	0.81
63	16.67	1.10	0.17	0.68	0.83	1.08

Calculation: (Example) MY1C25-300A

- Basic mass 1.58 kg
- Additional mass 0.24/50 st 1.58 + 0.24 x 300 ÷ 50 + 0.07 x 2 ≒ 3.16 kg
- Mass of A unit 0.07 kg
- Cylinder stroke.....300 st

Option

Stroke Adjusting Unit Part No.

Bore size (mm)		16	20	25	32	40	50	63
A unit	Left	MYM-A16A1	MYM-A20A1	MYM-A25A1	MYM-A32A1	MYM-A40A1	MYM-A50A1	MYM-A63A1
	Right	MYM-A16A2	MYM-A20A2	MYM-A25A2	MYM-A32A2	MYM-A40A2	MYM-A50A2	MYM-A63A2
L unit	Left	MYM-A16L1	MYM-A20L1	MYM-A25L1	MYM-A32L1	MYM-A40L1	MYM-A50L1	MYM-A63L1
	Right	MYM-A16L2	MYM-A20L2	MYM-A25L2	MYM-A32L2	MYM-A40L2	MYM-A50L2	MYM-A63L2
H unit	Left	—	MYM-A20H1	MYM-A25H1	MYM-A32H1	MYM-A40H1	MYM-A50H1	MYM-A63H1
	Right	—	MYM-A20H2	MYM-A25H2	MYM-A32H2	MYM-A40H2	MYM-A50H2	MYM-A63H2

Stroke adjusting unit form and mounting direction

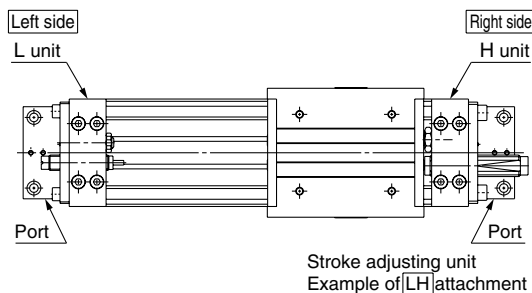

Side Support Part No.

Bore size (mm)		16	20	25	32	40	50	63
Side support A	Type	MY-S16A	MY-S20A	MY-S25A	MY-S32A	MY-S40A	MY-S50A	MY-S63A
Side support B	Type	MY-S16B	MY-S20B	MY-S25B	MY-S32B	MY-S40B	MY-S50B	MY-S63B

For details about dimensions, etc., refer to page 1013.
A set of side supports consists of a left support and a right support.

Series MY1C

Cushion Capacity

Cushion Selection

<Air cushion>

Air cushions are a standard feature on mechanically jointed rodless cylinders. The air cushion mechanism is incorporated to prevent excessive impact of the piston at the stroke end during high speed operation. The purpose of air cushion, thus, is not to decelerate the piston near the stroke end. The ranges of load and speed that air cushions can absorb are within the air cushion limit lines shown in the graphs.

<Stroke adjusting unit with shock absorber>
Use this unit when operating with a load or speed exceeding the air cushion limit line, or when cushioning is necessary because the cylinder stroke is outside of the effective air cushion stroke range due to stroke adjustment.

L unit

Use this unit when the cylinder stroke is outside of the effective air cushion range even if the load and speed are within the air cushion limit line, or when the cylinder is operated in a load and speed range above the air cushion limit line or below the L unit limit line.

H unit

Use this unit when the cylinder is operated in a load and speed range above the L unit limit line and below the H unit limit line.

⚠ Caution

1. Refer to the figure below when using the adjusting bolt to perform stroke adjustment.

When the effective stroke of the shock absorber decreases as a result of stroke adjustment, the absorption capacity decreases dramatically. Secure the adjusting bolt at the position where it protrudes approximately 0.5 mm from the shock absorber.

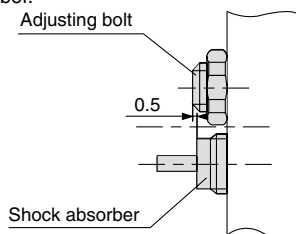

2. Do not use a shock absorber together with air cushion.

Air Cushion Stroke

(mm)

Bore size (mm)	Cushion stroke
16	12
20	15
25	15
32	19
40	24
50	30
63	37

Absorption Capacity of Air Cushion and Stroke Adjusting Units

MY1C16 Horizontal collision: P = 0.5 MPa

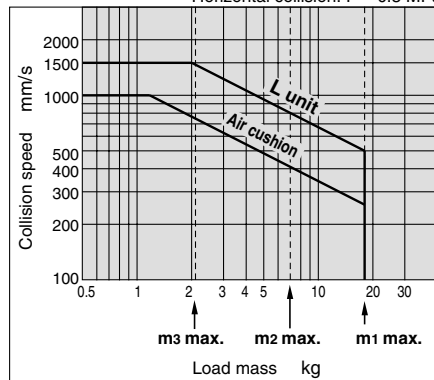

MY1C32 Horizontal collision: P = 0.5 MPa

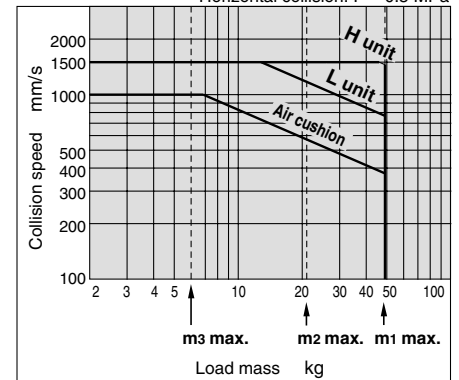

MY1C20 Horizontal collision: P = 0.5 MPa

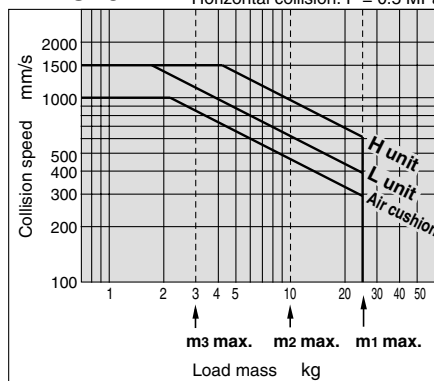

MY1C40 Horizontal collision: P = 0.5 MPa

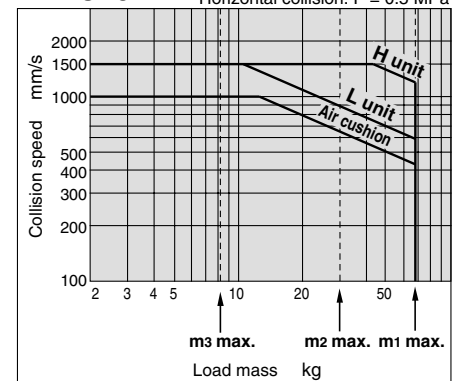

MY1C25 Horizontal collision: P = 0.5 MPa

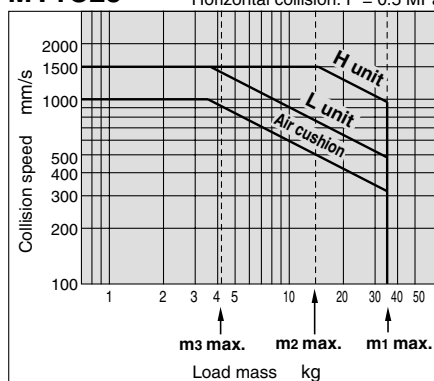

MY1C50 Horizontal collision: P = 0.5 MPa

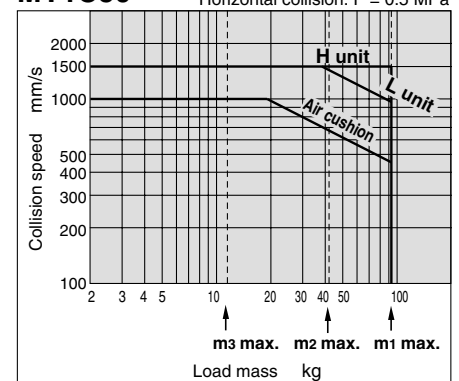

MY1C63 Horizontal collision: P = 0.5 MPa

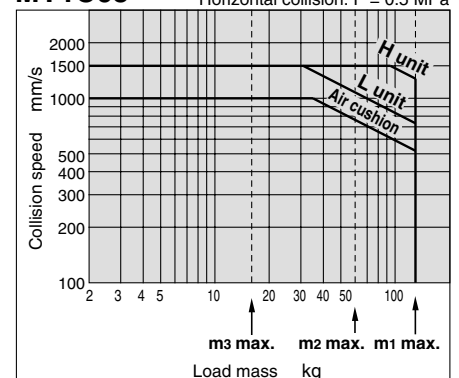

Tightening Torque for Stroke Adjusting Unit Holding Bolts (N·m)

Bore size (mm)	Unit	Tightening torque
16	A	0.7
	L	
20	A	1.8
	L	
	H	
25	A	3.5
	L	5.8
	H	13.8
32	A	5.8
	L	13.8
	H	13.8
40	A	13.8
	L	13.8
	H	13.8
50	A	13.8
	L	13.8
	H	13.8
63	A	27.5
	L	27.5
	H	27.5

Tightening Torque for Stroke Adjusting Unit Lock Plate Holding Bolts (N·m)

Bore size (mm)	Unit	Tightening torque
25	L	1.2
	H	3.3
32	L	3.3
	H	10
40	L	3.3
	H	10

Calculation of Absorbed Energy for Stroke Adjusting Unit with Shock Absorber (N·m)

Type of impact	Horizontal collision	Vertical (Downward)	Vertical (Upward)
Kinetic energy E_1	$\frac{1}{2} m \cdot v^2$		
Thrust energy E_2	$F \cdot s$	$F \cdot s + m \cdot g \cdot s$	$F \cdot s - m \cdot g \cdot s$
Absorbed energy E	$E_1 + E_2$		

Symbol

v : Speed of impact object (m/s)

F : Cylinder thrust (N)

s : Shock absorber stroke (m)

m : Mass of impact object (kg)

g : Gravitational acceleration (9.8 m/s²)

Note) The speed of the impact object is measured at the time of impact with the shock absorber.

⚠ Precautions

Be sure to read before handling. Refer to front matters 54 and 55 for Safety Instructions and pages 3 to 11 for Actuator and Auto Switch Precautions.

⚠ Caution

Use caution not to get your hands caught in the unit.

- When using a product with stroke adjusting unit, the space between the slide table (slider) and the stroke adjusting unit becomes narrow at the stroke end, causing a danger of hands getting caught. Install a protective cover to prevent direct contact with the human body.

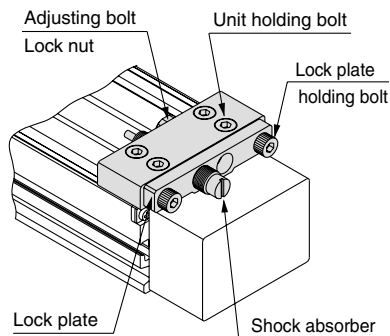

<Fastening of unit>

The unit can be secured by evenly tightening the four unit holding bolts.

⚠ Caution

Do not operate with the stroke adjusting unit fixed in an intermediate position.

When the stroke adjusting unit is fixed in an intermediate position, slippage can occur depending on the amount of energy released at the time of an impact. In such cases, the use of the adjusting bolt mounting brackets, available per made-to-order specifications -X416 and -X417, is recommended.

For other lengths, please consult with SMC (Refer to "Tightening Torque for Stroke Adjusting Unit Holding Bolts".)

<Stroke adjustment with adjusting bolt>

Loosen the adjusting bolt lock nut, and adjust the stroke from the lock plate side using a hexagon wrench. Retighten the lock nut.

<Stroke adjustment with shock absorber>

Loosen the two lock plate holding bolts, turn the shock absorber and adjust the stroke. Then, uniformly tighten the lock plate holding bolts to secure the shock absorber.

Take care not to over-tighten the holding bolts. (Except $\varnothing 16$, $\varnothing 20$, $\varnothing 50$, $\varnothing 63$)

(Refer to "Tightening Torque for Stroke Adjusting Unit Lock Plate Holding Bolts".)

Note) Although the lock plate may slightly bend due to tightening of the lock plate holding bolt, this does not affect the shock absorber and locking function.

MY1B

MY1M

MY1C

MY1H

MY1HT

MY1□W

MY2C

MY2H□

MY3A

MY3B

MY3M

D-□

-X□

Individual

-X□

Technical

data

Series MY1C

Construction: $\varnothing 16$ to $\varnothing 63$

MY1C16 to 63

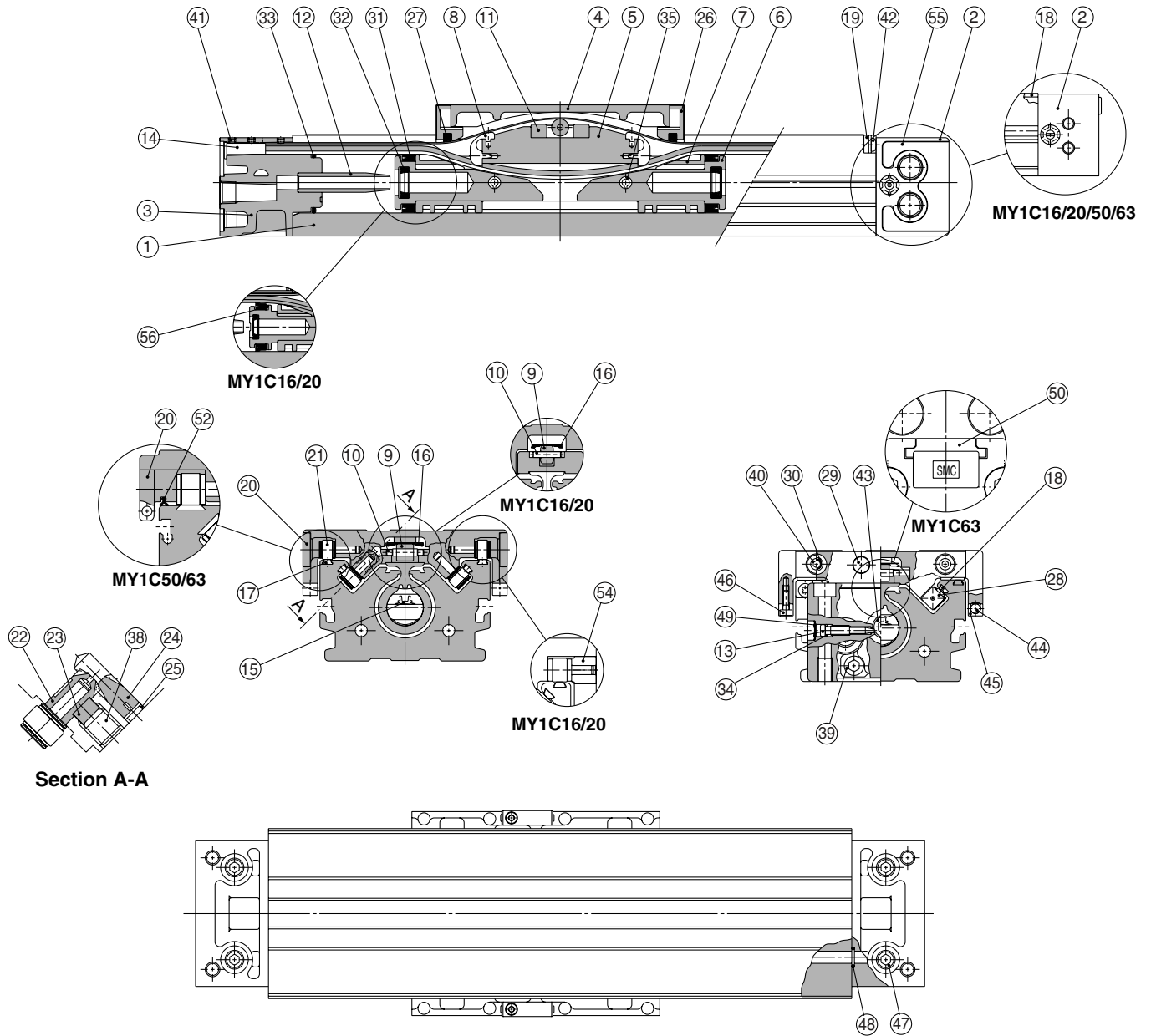

MY1C16 to 63

Component Parts

No.	Description	Material	Note
1	Cylinder tube	Aluminum alloy	Hard anodized
2	Head cover WR	Aluminum alloy	Painted
3	Head cover WL	Aluminum alloy	Painted
4	Slide table	Aluminum alloy	Electroless nickel plated
5	Piston yoke	Aluminum alloy	Chromated
6	Piston	Aluminum alloy	Chromated
7	Wear ring	Special resin	
8	Belt separator	Special resin	
9	Guide roller	Special resin	
10	Guide roller shaft	Stainless steel	
11	Coupler	Sintered iron material	
12	Cushion ring	Brass	
13	Cushion needle	Rolled steel	Nickel plated
14	Belt clamp	Special resin	
17	Rail	Hard steel wire	
18	End spacer	Special resin	
19	End clamp	Stainless steel	Rubber lining (ø25 to ø40)
20	Cam follower cap	Special resin	(ø25 to ø40)
21	Cam follower	—	
22	Eccentric gear	Stainless steel	
23	Gear bracket	Stainless steel	
24	Adjustment gear	Stainless steel	
25	Retaining ring	Stainless steel	

No.	Description	Material	Note
26	End Cover	Special resin	
28	Backup plate	Special resin	
29	Stopper	Carbon steel	Nickel plated
30	Spacer	Stainless steel	
35	Spring pin	Carbon tool steel	Black zinc chromated
38	Hexagon socket head set screw	Chromium molybdenum steel	Black zinc chromated
39	Hexagon socket head cap screw	Chromium molybdenum steel	Nickel plated
40	Hexagon socket button head screw	Chromium molybdenum steel	Nickel plated
41	Hexagon socket head set screw	Chromium molybdenum steel	Black zinc chromated/Nickel plated
42	Round head Phillips screw	Chromium molybdenum steel	Nickel plated
43	Hexagon socket head taper plug	Carbon steel	Nickel plated
44	Magnet	—	
45	Magnet holder	Special resin	
46	Hexagon socket head cap screw	Chromium molybdenum steel	Nickel plated
47	Hexagon socket head taper plug	Carbon steel	Nickel plated
49	Type CR retaining ring	Spring steel	
50	Head plate	Aluminum alloy	Hard anodized (ø63)
52	Side scraper	Special resin	(ø50 to ø63)
54	Bushing	Aluminum alloy	(ø16 to ø20)
55	Port cover	Special resin	(ø25 to ø40)
56	Lube retainer	Special resin	(ø16 to ø20)

MY1B

MY1M

MY1C

MY1H

MY1HT

MY1□W

MY2C

MY2H□

MY3A

MY3B

MY3M

Replacement Part: Seal Kit

No.	Description	Qty.	MY1C16	MY1C20	MY1C25	MY1C32	MY1C40	MY1C50	MY1C63
15	Seal belt	1	MY16-16A-[Stroke]	MY20-16A-[Stroke]	MY25-16A-[Stroke]	MY32-16A-[Stroke]	MY40-16A-[Stroke]	MY50-16A-[Stroke]	MY63-16A-[Stroke]
16	Dust seal band	1	MY16-16B-[Stroke]	MY20-16B-[Stroke]	MY25-16B-[Stroke]	MY32-16B-[Stroke]	MY40-16B-[Stroke]	MY50-16B-[Stroke]	MY63-16B-[Stroke]
34	O-ring	2	ø4 x ø1.8 x ø1.1	ø5.1 x ø3 x ø1.05	ø5.1 x ø3 x ø1.05	ø7.15 x ø3.75 x ø1.7	ø8.3 x ø4.5 x ø1.9	C4	C4
52	Side scraper	2	—	—	—	—	—	MYM50-15CK0502B	MYM63-15CK0503B
27	Scraper	2							
31	Piston seal	2							
32	Cushion seal	2	MY1M16-PS	MY1M20-PS	MY1M25-PS	MY1M32-PS	MY1M40-PS	MY1M50-PS	MY1M63-PS
33	Tube gasket	2							
48	O-ring	4							

* Seal kit includes 27, 31, 32, 33 and 48. Order the seal kit based on each bore size.

* Seal kit includes a grease pack (10 g).

When 15 and 16 are shipped independently, a grease pack is included. (10 g per 1000 strokes)

Order with the following part number when only the grease pack is needed.

Grease pack part number: GR-S-010 (10 g), GR-S-020 (20 g)

Note) Two kinds of dust seal bands are available. Verify the type to use, since the part number varies depending on the treatment of the hexagon socket head set screw 41.

A: Black zinc chromated → MY□□-16B-stroke, B: Nickel plated → MY□□-16BW-stroke

D-□

-X□

Individual
-X□

Technical
data

Series MY1C

Standard Type/Centralized Piping Type $\phi 16, \phi 20$

Refer to page 1056 regarding centralized piping port variations.

MY1C16□/20□ — Stroke

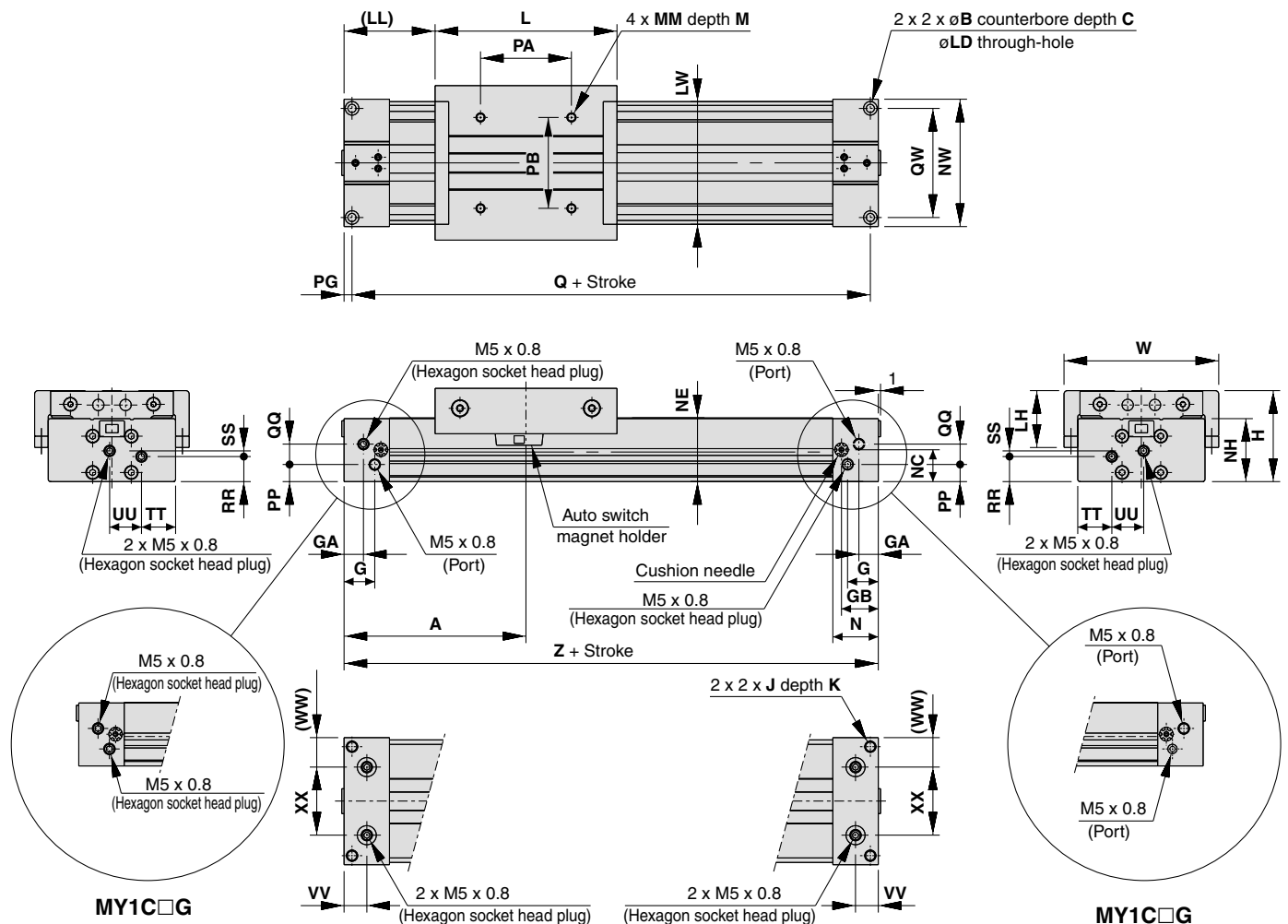

Model	A	B	C	G	GA	GB	H	J	K	L	LD	LH	LL	LW	M	MM	N	NC
MY1C16□	80	6	3.5	13.5	8.5	16.2	40	M5 x 0.8	10	80	3.6	22.5	40	54	6	M4 x 0.7	20	14
MY1C20□	100	7.5	4.5	12.5	12.5	20	46	M6 x 1	12	100	4.8	23	50	58	7.5	M5 x 0.8	25	17

Model	NE	NH	NW	PA	PB	PG	PP	Q	QQ	QW	RR	SS	TT	UU	VV	W	WW	XX	Z
MY1C16□	28	27.7	56	40	40	3.5	7.5	153	9	48	11	2.5	15	14	10	68	13	30	160
MY1C20□	34	33.7	60	50	40	4.5	11.5	191	10	45	14.5	5	18	12	12.5	72	14	32	200

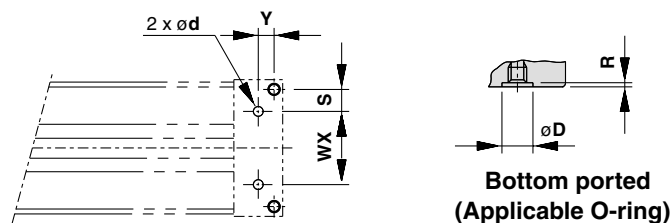

Hole Sizes for Centralized Piping on the Bottom

Model	WX	Y	S	d	D	R	Applicable O-ring
MY1C16□	30	6.5	9	4	8.4	1.1	C6
MY1C20□	32	8	6.5	4	8.4	1.1	

(Machine the mounting side to the dimensions below.)

Mechanically Jointed Rodless Cylinder Cam Follower Guide Type **Series MY1C**

Standard Type/Centralized Piping Type $\phi 25, \phi 32, \phi 40$ Refer to page 1056 regarding centralized piping port variations.

MY1C25□/32□/40□ — Stroke

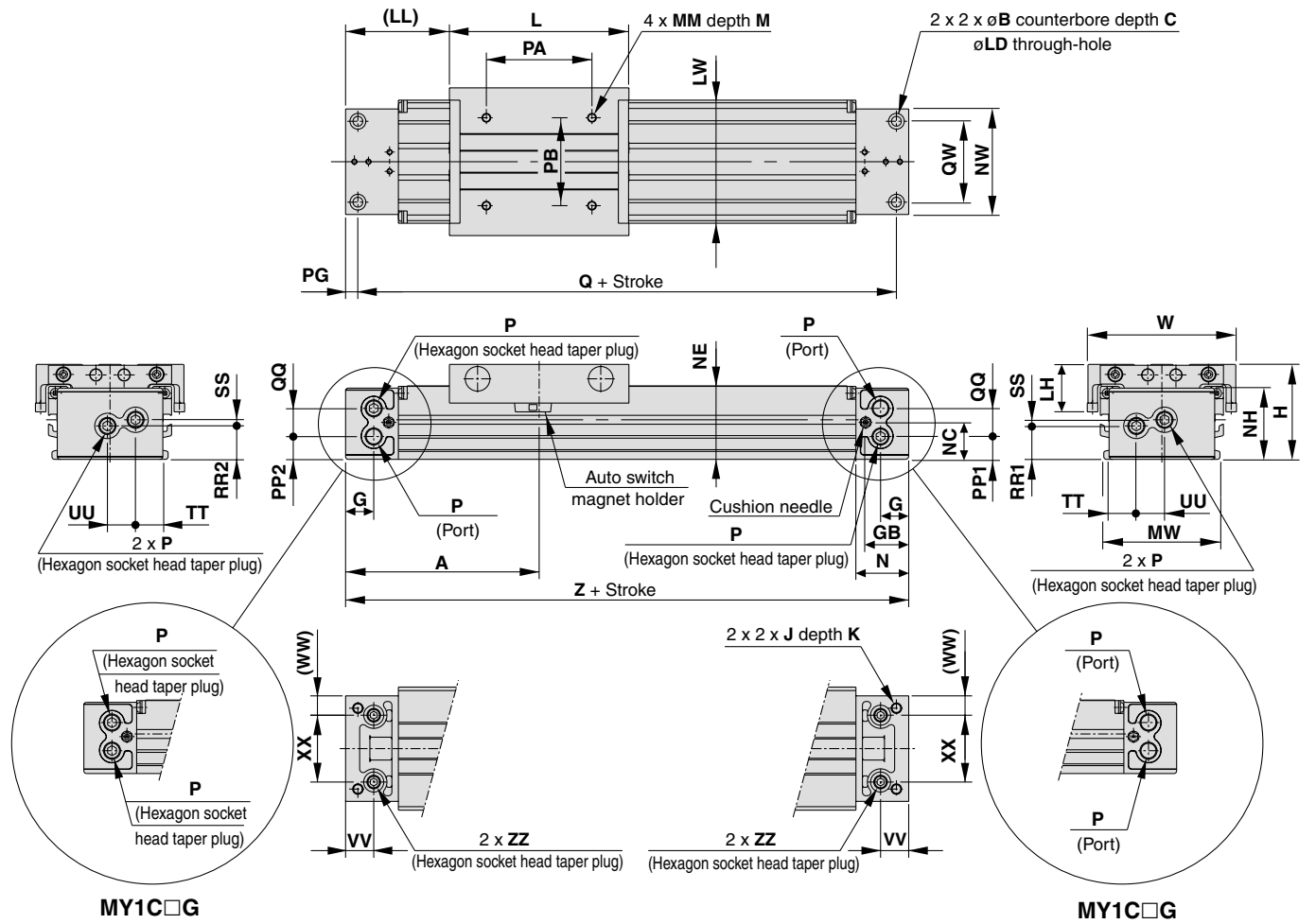

- MY1B
- MY1M
- MY1C**
- MY1H
- MY1HT
- MY1□W
- MY2C
- MY2H□
- MY3A
- MY3B
- MY3M

Model	A	B	C	G	GB	H	J	K	L	LD	LH	LL	LW	M	MM	MW	N	NC	NE	NH	NW	P	PA
MY1C25□	110	9	5.5	17	24.5	54	M6 x 1	9.5	102	5.6	27	59	70	10	M5 x 0.8	66	30	21	41.8	40.5	60	Rc 1/8	60
MY1C32□	140	11	6.5	19	30	68	M8 x 1.25	16	132	6.8	35	74	88	13	M6 x 1	80	37	26	52.3	50	74	Rc 1/8	80
MY1C40□	170	14	8.5	23	36.5	84	M10 x 1.5	15	162	8.6	38	89	104	13	M6 x 1	96	45	32	65.3	63.5	94	Rc 1/4	100

"P" indicates cylinder supply ports.

Model	PB	PG	PP1	PP2	Q	QQ	QW	RR1	RR2	SS	TT	UU	VV	W	WW	XX	Z	ZZ
MY1C25□	50	7	12.7	12.7	206	15.5	46	18.9	17.9	4.1	15.5	16	16	84	11	38	220	Rc 1/16
MY1C32□	60	8	15.5	18.5	264	16	60	22	24	4	21	16	19	102	13	48	280	Rc 1/16
MY1C40□	80	9	17.5	20	322	26	72	25.5	29	9	26	21	23	118	20	54	340	Rc 1/8

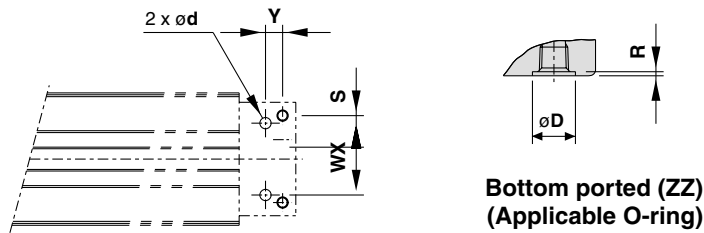

Hole Size for Centralized Piping on the Bottom

Model	WX	Y	S	d	D	R	Applicable O-ring
MY1C25□	38	9	4	6	11.4	1.1	C9
MY1C32□	48	11	6	6	11.4	1.1	
MY1C40□	54	14	9	8	13.4	1.1	C11.2

(Machine the mounting side to the dimensions below.)

- D-□
- X□
- Individual
- X□
- Technical data

Series MY1C

Standard Type/Centralized Piping Type $\phi 50, \phi 63$

Refer to page 1056 regarding centralized piping port variations.

MY1C50□/63□ — Stroke

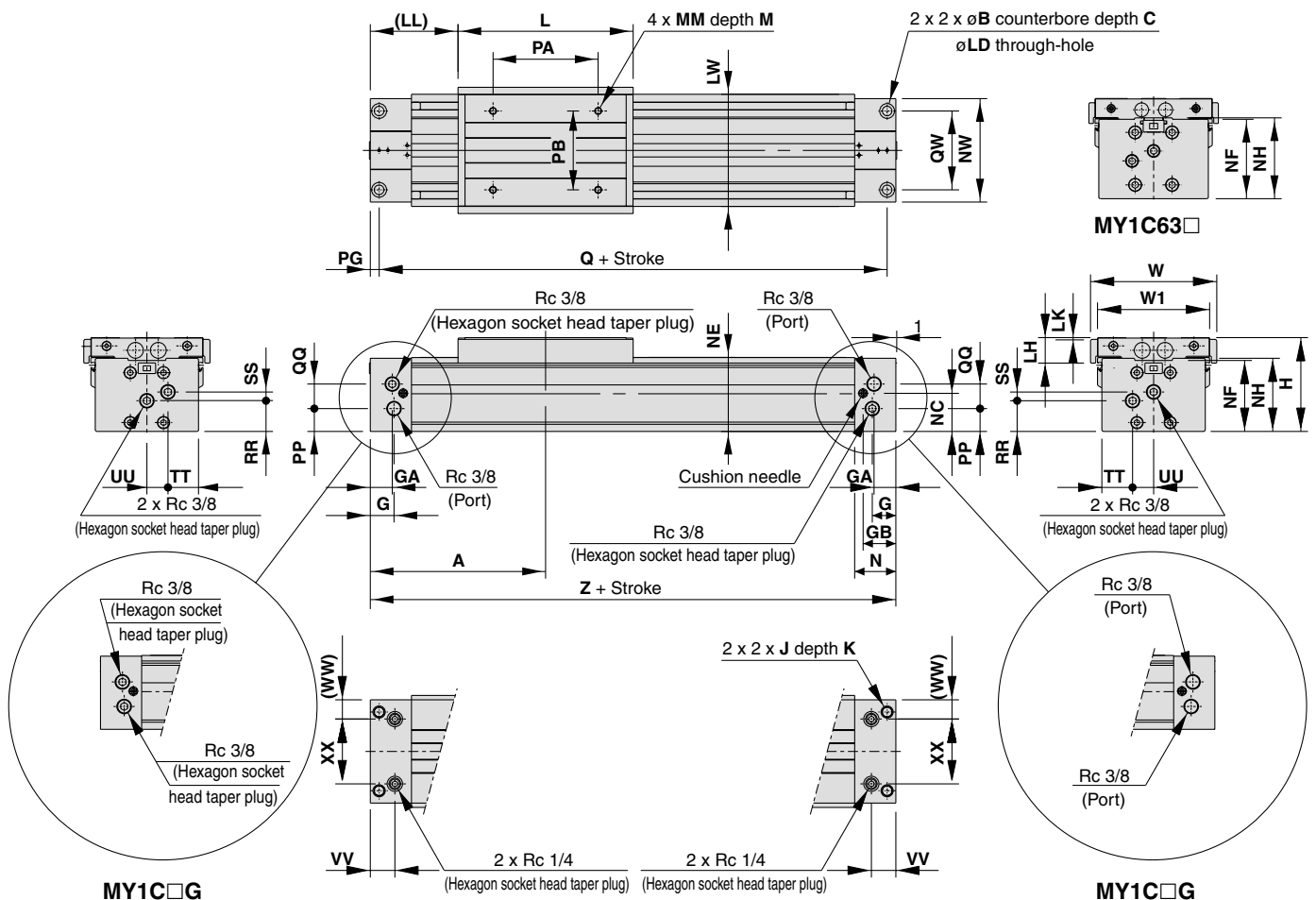

(mm)

Model	A	B	C	G	GA	GB	H	J	K	L	LD	LH	LK	LL	LW	M	MM	N	NC	NE
MY1C50□	200	17	10.5	27	25	37.5	107	M14 x 2	28	200	11	29	2	100	128	15	M8 x 1.25	47	43.5	84.5
MY1C63□	230	19	12.5	29.5	27.5	39.5	130	M16 x 2	32	230	13.5	32.5	5.5	115	152	16	M10 x 1.5	50	60	104

(mm)

Model	NF	NH	NW	PA	PB	PG	PP	Q	QQ	QW	RR	SS	TT	UU	VV	W	W1	WW	XX	Z
MY1C50□	81	83.5	118	120	90	10	26	380	28	90	35	10	35	24	28	144	128	22	74	400
MY1C63□	103	105	142	140	110	12	42	436	30	110	49	13	43	28	30	168	152	25	92	460

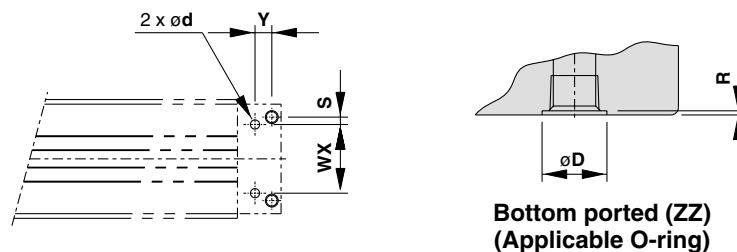

Bottom ported (ZZ)
(Applicable O-ring)

Hole Size for Centralized Piping on the Bottom

Model	WX	Y	S	d	D	R	Applicable O-ring
MY1C50□	74	18	8	10	17.5	1.1	C15
MY1C63□	92	18	9	10	17.5	1.1	

(Machine the mounting side to the dimensions below.)

Stroke Adjusting Unit

With adjusting bolt

MY1C Bore size — Stroke A

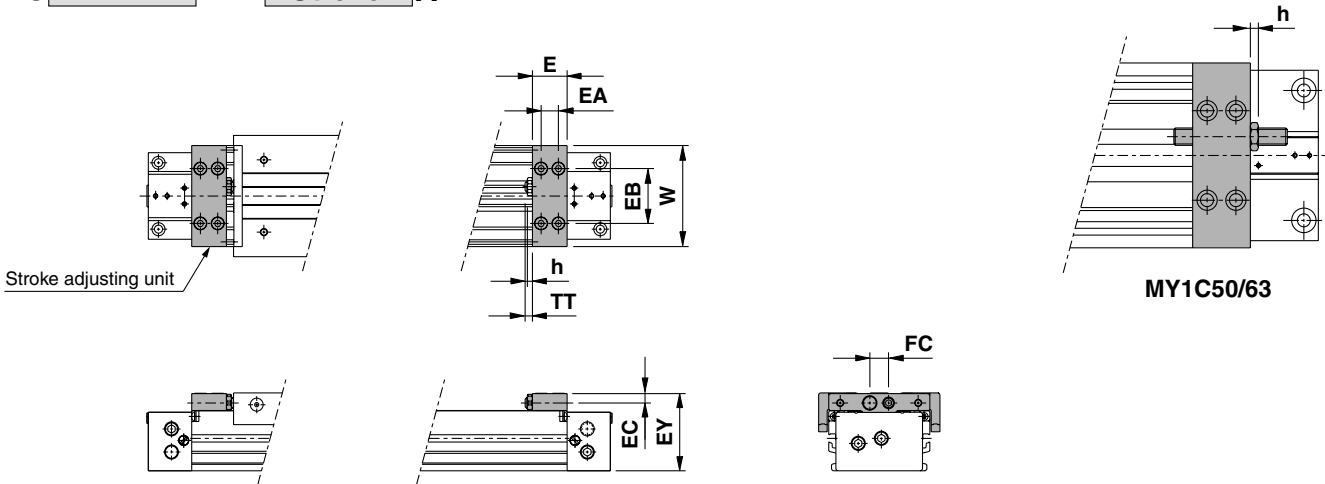

Applicable bore size	E	EA	EB	EC	EY	FC	h	TT	W
MY1C16	14.6	7	30	5.8	39.5	14	3.6	5.4 (Max. 11)	58
MY1C20	20	10	32	5.8	45.5	14	3.6	5 (Max. 11)	58
MY1C25	24	12	38	6.5	53.5	13	3.5	5 (Max. 16.5)	70
MY1C32	29	14	50	8.5	67	17	4.5	8 (Max. 20)	88
MY1C40	35	17	57	10	83	17	4.5	9 (Max. 25)	104
MY1C50	40	20	66	14	106	26	5.5	13 (Max. 33)	128
MY1C63	52	26	77	14	129	31	5.5	13 (Max. 38)	152

- MY1B
- MY1M
- MY1C**
- MY1H
- MY1HT
- MY1□W
- MY2C
- MY2H□
- MY3A
- MY3B
- MY3M

With low load shock absorber + Adjusting bolt

MY1C Bore size — Stroke L

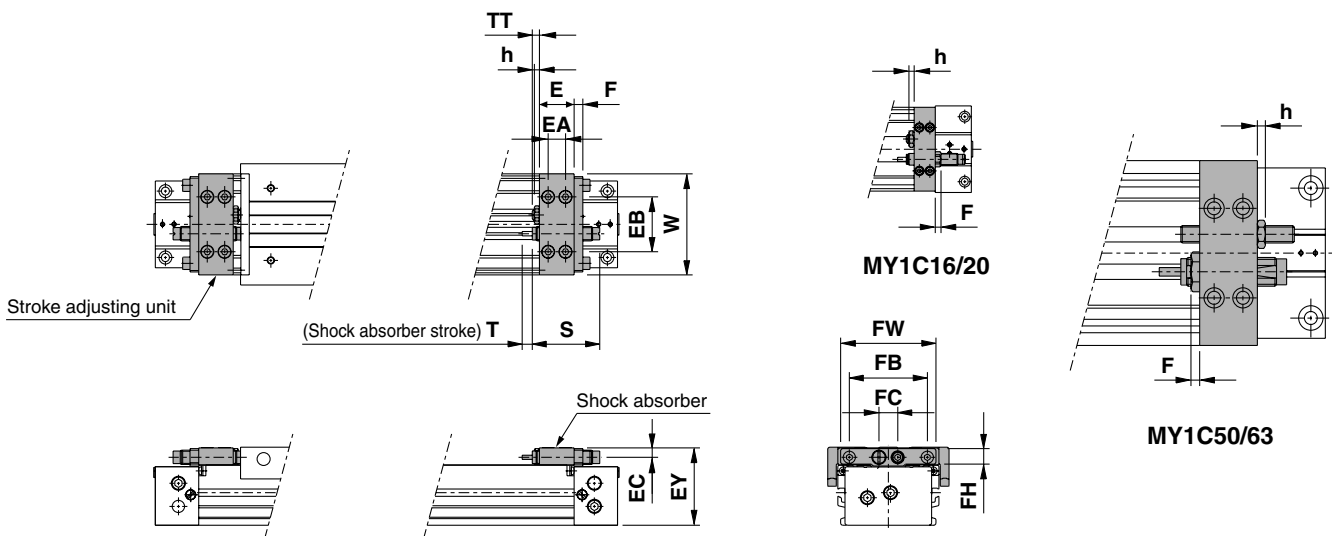

Applicable bore size	E	EA	EB	EC	EY	F	FB	FC	FH	FW	h	S	T	TT	W	Shock absorber model
MY1C16	14.6	7	30	5.8	39.5	4	—	14	—	—	3.6	40.8	6	5.4 (Max. 11)	58	RB0806
MY1C20	20	10	32	5.8	45.5	4	—	14	—	—	3.6	40.8	6	5 (Max. 11)	58	RB0806
MY1C25	24	12	38	6.5	53.5	6	54	13	13	66	3.5	46.7	7	5 (Max. 16.5)	70	RB1007
MY1C32	29	14	50	8.5	67	6	67	17	16	80	4.5	67.3	12	8 (Max. 20)	88	RB1412
MY1C40	35	17	57	10	83	6	78	17	17.5	91	4.5	67.3	12	9 (Max. 25)	104	RB1412
MY1C50	40	20	66	14	106	6	—	26	—	—	5.5	73.2	15	13 (Max. 33)	128	RB2015
MY1C63	52	26	77	14	129	6	—	31	—	—	5.5	73.2	15	13 (Max. 38)	152	RB2015

- D-□
- X□
- Individual
- X□
- Technical data

Series MY1C

Stroke Adjusting Unit

With high load shock absorber + Adjusting bolt

MY1C Bore size □ — Stroke H

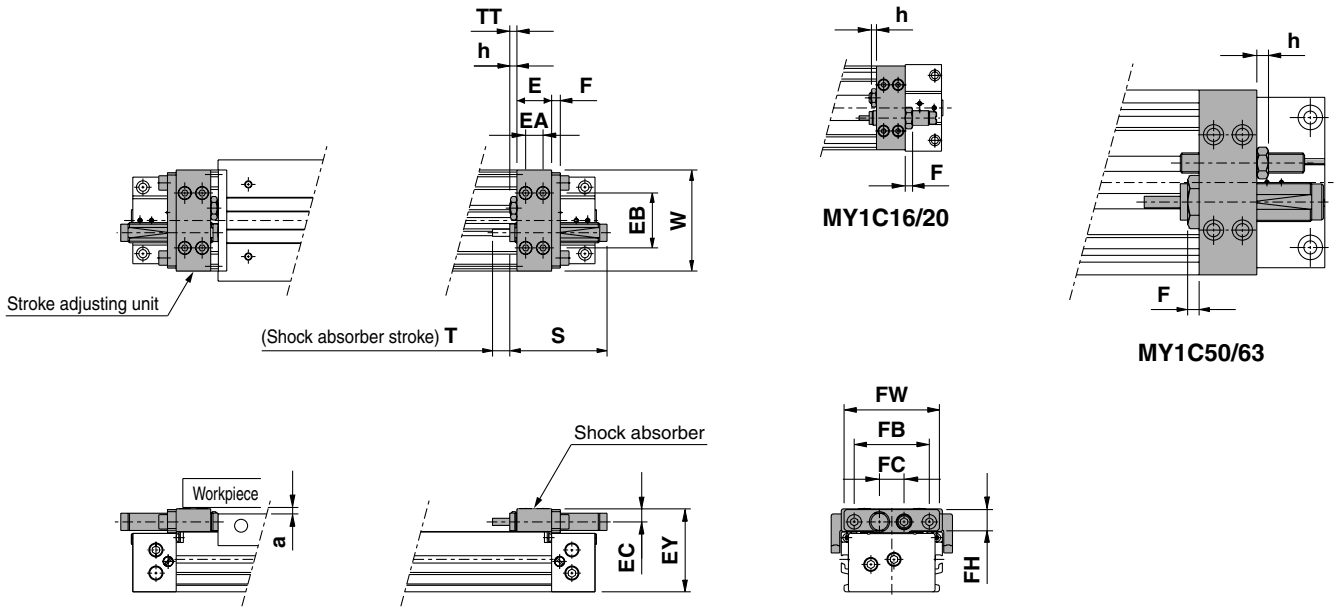

* Since dimension EY of the H type unit is greater than the table top height (dimension H), when mounting a workpiece that exceeds the overall length (dimension L) of the slide table, allow a clearance of dimension "a" or larger on the workpiece side.

Applicable bore size	E	EA	EB	EC	EY	F	FB	FC	FH	FW	h	S	T	TT	W	Shock absorber model	a
MY1C20	20	10	32	7.7	50	5	—	14	—	—	3.5	46.7	7	5 (Max. 11)	58	RB1007	5
MY1C25	24	12	38	9	57.5	6	52	17	16	66	4.5	67.3	12	5 (Max. 16.5)	70	RB1412	4.5
MY1C32	29	14	50	11.5	73	8	67	22	22	82	5.5	73.2	15	8 (Max. 20)	88	RB2015	6
MY1C40	35	17	57	12	87	8	78	22	22	95	5.5	73.2	15	9 (Max. 25)	104	RB2015	4
MY1C50	40	20	66	18.5	115	8	—	30	—	—	11	99	25	13 (Max. 33)	128	RB2725	9
MY1C63	52	26	77	19	138.5	8	—	35	—	—	11	99	25	13 (Max. 38)	152	RB2725	9.5

Side Support

Side support A MY-S□A

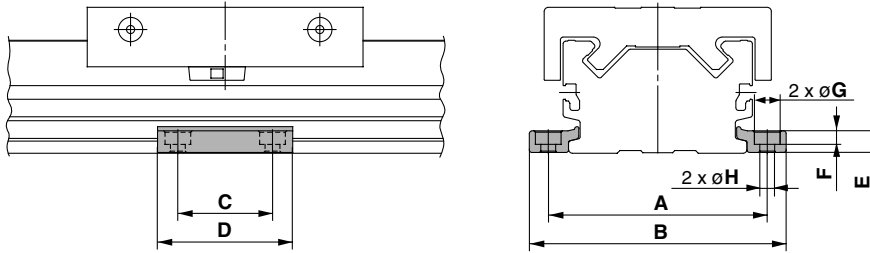

Side support B MY-S□B

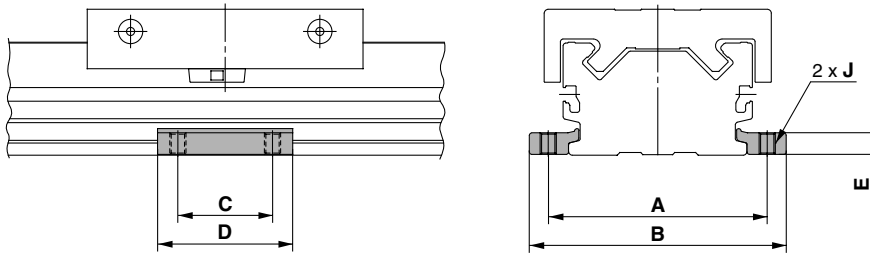

Model	Applicable bore size	A	B	C	D	E	F	G	H	J	(mm)
MY-S16 ^A _B	MY1C16	61	71.6	15	26	4.9	3	6.5	3.4	M4 x 0.7	
MY-S20 ^A _B	MY1C20	67	79.6	25	38	6.4	4	8	4.5	M5 x 0.8	
MY-S25 ^A _B	MY1C25	81	95	35	50	8	5	9.5	5.5	M6 x 1	
MY-S32 ^A _B	MY1C32	100	118	45	64	11.7	6	11	6.6	M8 x 1.25	
MY-S40 ^A _B	MY1C40	120	142	55	80	14.8	8.5	14	9	M10 x 1.5	
	MY1C50	142	164								
MY-S63 ^A _B	MY1C63	172	202	70	100	18.3	10.5	17.5	11.5	M12 x 1.75	

* A set of side supports consists of a left support and a right support.

Guide for Side Support Application

For long stroke operation, the cylinder tube may be deflected depending on its own weight and the load weight. In such a case, use a side support in the middle section. The spacing (ℓ) of the support must be no more than the values shown in the graph on the right.

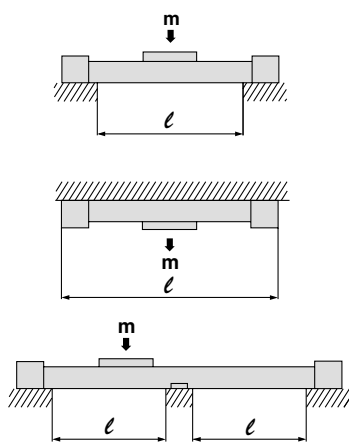

⚠ Caution

1. If the cylinder mounting surfaces are not measured accurately, using a side support may cause poor operation. Therefore, be sure to level the cylinder tube when mounting. Also, for long stroke operation involving vibration and impact, use of a side support is recommended even if the spacing value is within the allowable limits shown in the graph.
2. Support brackets are not for mounting; use them solely for providing support.

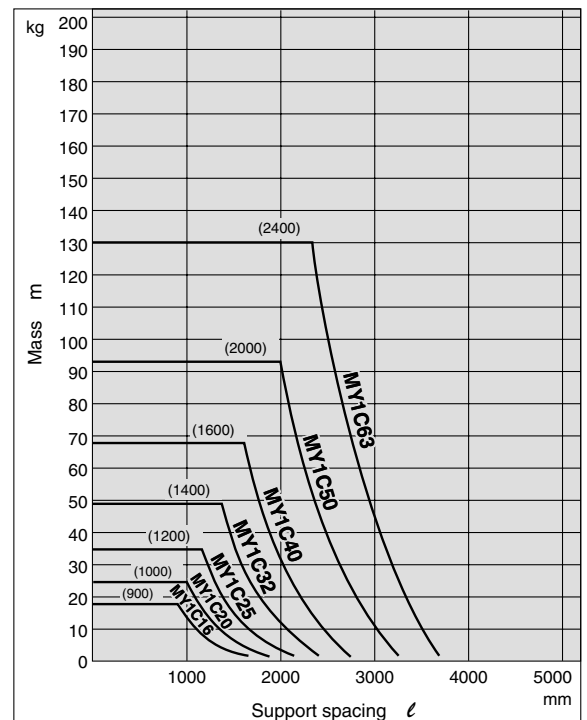

MY1B

MY1M

MY1C

MY1H

MY1HT

MY1□W

MY2C

MY2H□

MY3A

MY3B

MY3M

D-□

-X□

Individual

-X□

Technical

data

Series MY1H

Linear Guide Type

ø10, ø16, ø20, ø25, ø32, ø40

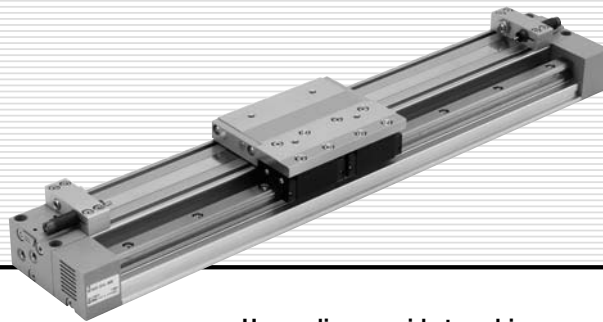

Uses a linear guide to achieve high repeatability

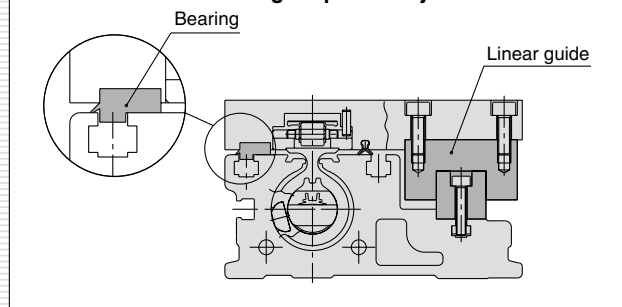

End lock type capable of holding a position at the stroke end (Except bore size ø10)

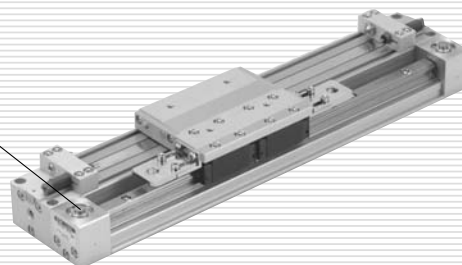

MY1B

MY1M

MY1C

MY1H

MY1HT

MY1□W

MY2C

MY2H□

MY3A
MY3B

MY3M

D-□

-X□

Individual
-X□

Technical
data

Series MY1H Prior to Use

Maximum Allowable Moment/Maximum Load Mass

Model	Bore size (mm)	Maximum allowable moment (N·m)			Maximum load mass (kg)		
		M ₁	M ₂	M ₃	m ₁	m ₂	m ₃
MY1H	10	0.8	1.1	0.8	6.1	6.1	6.1
	16	3.7	4.9	3.7	10.8	10.8	10.8
	20	11	16	11	17.6	17.6	17.6
	25	23	26	23	27.5	27.5	27.5
	32	39	50	39	39.2	39.2	39.2
	40	50	50	39	50	50	50

The above values are the maximum allowable values for moment and load. Refer to each graph regarding the maximum allowable moment and maximum allowable load for a particular piston speed.

Maximum Allowable Moment

Select the moment from within the range of operating limits shown in the graphs. Note that the maximum allowable load value may sometimes be exceeded even within the operating limits shown in the graphs. Therefore, also check the allowable load for the selected conditions.

Load mass (kg)

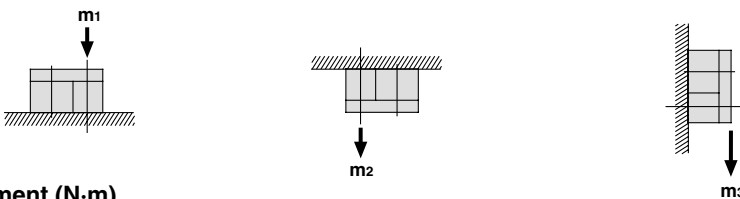

Moment (N·m)

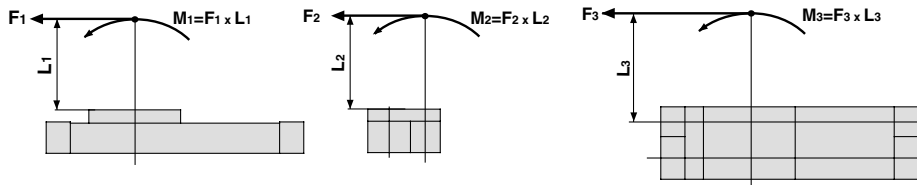

<Calculation of guide load factor>

1. Maximum allowable load (1), static moment (2), and dynamic moment (3) (at the time of impact with stopper) must be examined for the selection calculations.

* To evaluate, use v_a (average speed) for (1) and (2), and v (collision speed $v = 1.4v_a$) for (3). Calculate m_{max} for (1) from the maximum allowable load graph (m_1, m_2, m_3) and M_{max} for (2) and (3) from the maximum allowable moment graph (M_1, M_2, M_3).

$$\text{Sum of guide load factors } \Sigma \alpha = \frac{\text{Load mass [m]}}{\text{Maximum allowable load [m}_{max}]} + \frac{\text{Static moment [M]}^{(1)}}{\text{Allowable static moment [M}_{max}]} + \frac{\text{Dynamic moment [M}_E]^{(2)}}{\text{Allowable dynamic moment [M}_{Emax}}} \leq 1$$

Note 1) Moment caused by the load, etc., with cylinder in resting condition.

Note 2) Moment caused by the impact load equivalent at the stroke end (at the time of impact with stopper).

Note 3) Depending on the shape of the workpiece, multiple moments may occur. When this happens, the sum of the load factors ($\Sigma \alpha$) is the total of all such moments.

2. Reference formula [Dynamic moment at impact]

Use the following formulae to calculate dynamic moment when taking stopper impact into consideration.

- m:** Load mass (kg)
- F:** Load (N)
- F_E:** Load equivalent to impact (at impact with stopper) (N)
- v_a:** Average speed (mm/s)
- M:** Static moment (N·m)
- v:** Collision speed (mm/s)
- L₁:** Distance to the load's center of gravity (m)
- M_E:** Dynamic moment (N·m)
- δ:** Damper coefficient
 - With rubber bumper = 4/100 (MY1B10, MY1H10)
 - With air cushion = 1/100
 - With shock absorber = 1/100
- g:** Gravitational acceleration (9.8 m/s²)

$$v = 1.4v_a \text{ (mm/s)} \quad F_E = 1.4v_a \cdot \delta \cdot m \cdot g$$

$$\therefore M_E = \frac{1}{3} \cdot F_E \cdot L_1 = 4.57v_a \delta m L_1 \text{ (N·m)}$$

Note 4) $1.4v_a \delta$ is a dimensionless coefficient for calculating impact force.

Note 5) Average load coefficient ($= \frac{1}{3}$): This coefficient is for averaging the maximum load moment at the time of stopper impact according to service life calculations.

3. For detailed selection procedures, refer to pages 1018 and 1019.

Maximum Load Mass

Select the load from within the range of limits shown in the graphs. Note that the maximum allowable moment value may sometimes be exceeded even within the operating limits shown in the graphs. Therefore, also check the allowable moment for the selected conditions.

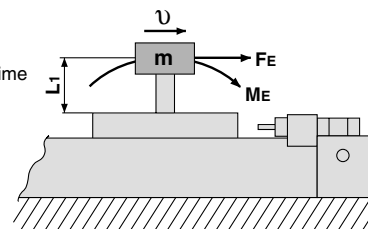

MY1H/M₁

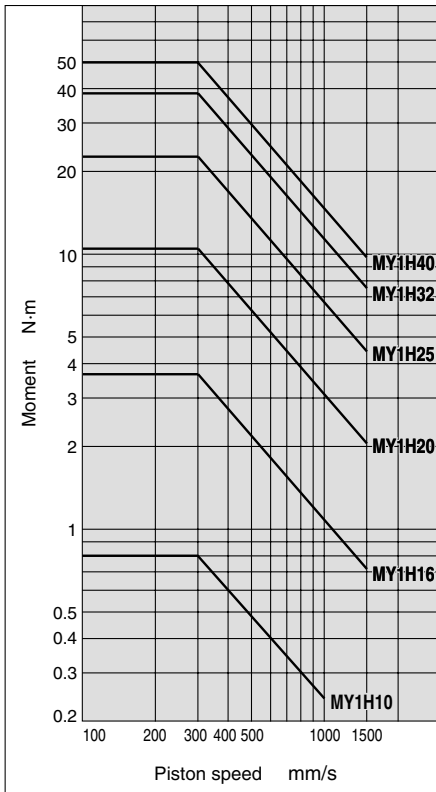

MY1H/M₂

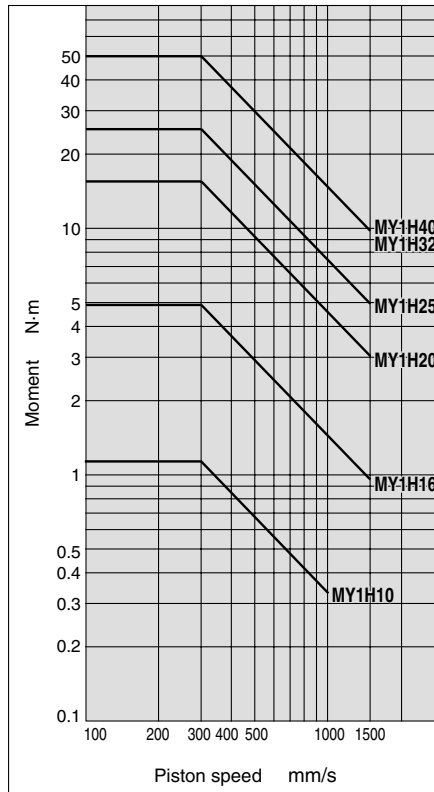

MY1H/M₃

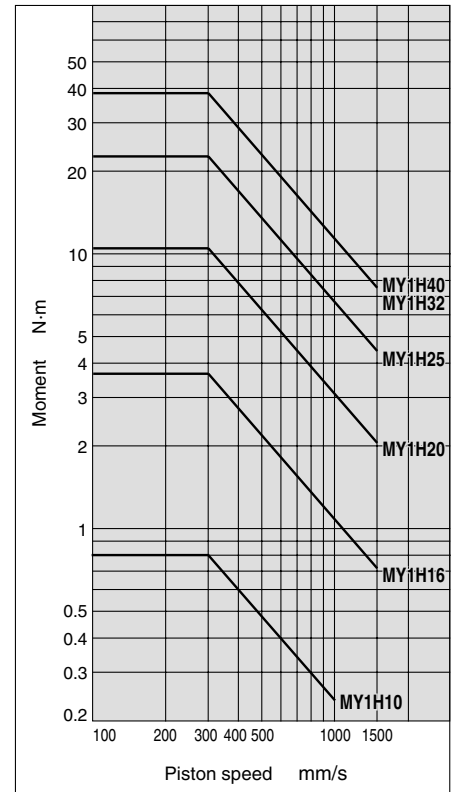

MY1B

MY1M

MY1C

MY1H

MY1HT

MY1□W

MY2C

MY2H□

MY3A

MY3B

MY3M

MY1H/m₁

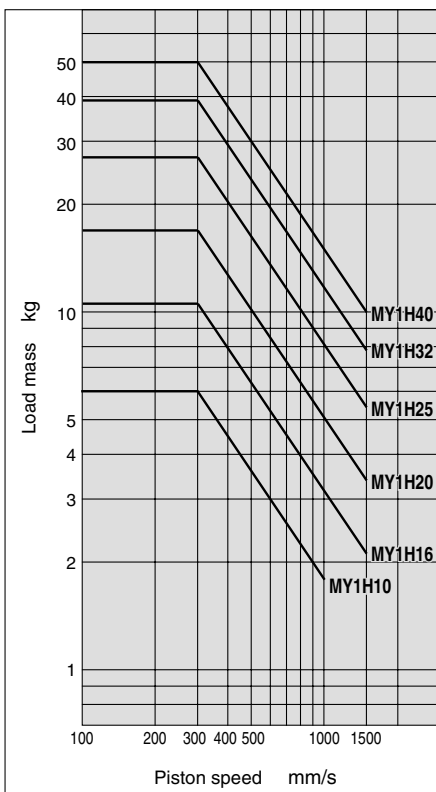

MY1H/m₂

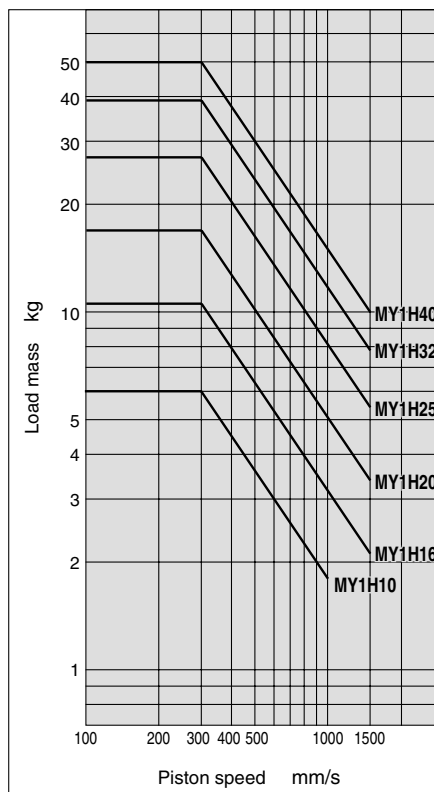

MY1H/m₃

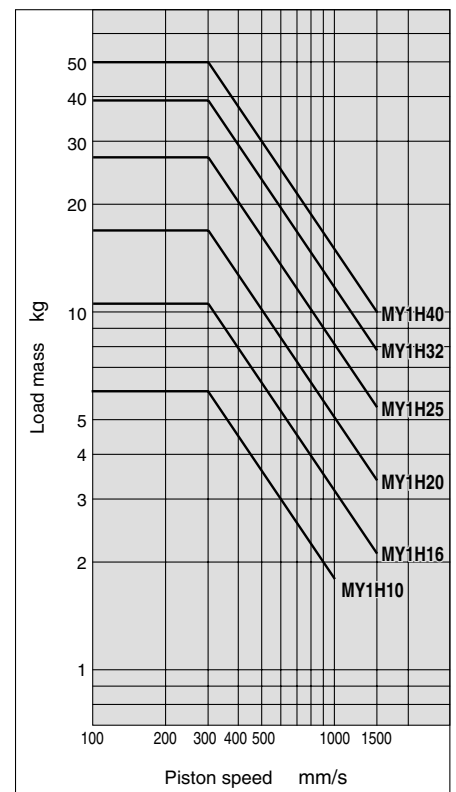

D-□

-X□

Individual

-X□

Technical data

Series MY1H Model Selection

Following are the steps for selecting the most suitable Series MY1H to your application.

Calculation of Guide Load Factor

1. Operating Conditions

Operating cylinder MY1H40-500
 Average operating speed v_a ... 300 mm/s
 Mounting orientation Wall mounting
 Cushion Air cushion ($\delta = 1/100$)

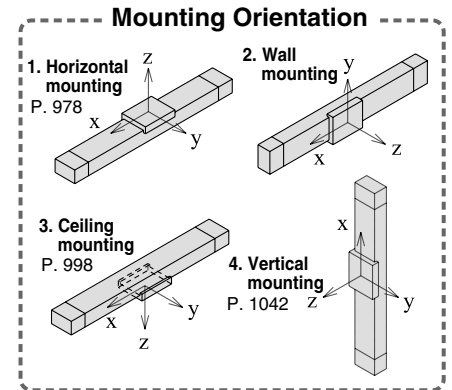
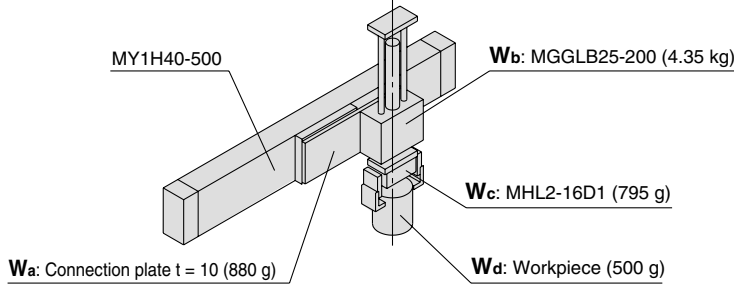

For actual examples of calculation for each orientation, refer to the pages above.

2. Load Blocking

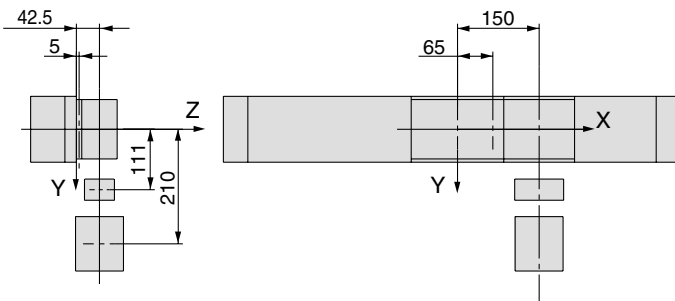

Mass and Center of Gravity for Each Workpiece

Workpiece no. W_n	Mass m_n	Center of gravity		
		X-axis X_n	Y-axis Y_n	Z-axis Z_n
W_a	0.88 kg	65 mm	0 mm	5 mm
W_b	4.35 kg	150 mm	0 mm	42.5 mm
W_c	0.795 kg	150 mm	111 mm	42.5 mm
W_d	0.5 kg	150 mm	210 mm	42.5 mm

$n=a, b, c, d$

3. Composite Center of Gravity Calculation

$$m_3 = \sum m_n$$

$$= 0.88 + 4.35 + 0.795 + 0.5 = 6.525 \text{ kg}$$

$$X = \frac{1}{m_3} \times \sum (m_n \times x_n)$$

$$= \frac{1}{6.525} (0.88 \times 65 + 4.35 \times 150 + 0.795 \times 150 + 0.5 \times 150) = 138.5 \text{ mm}$$

$$Y = \frac{1}{m_3} \times \sum (m_n \times y_n)$$

$$= \frac{1}{6.525} (0.88 \times 0 + 4.35 \times 0 + 0.795 \times 111 + 0.5 \times 210) = 29.6 \text{ mm}$$

$$Z = \frac{1}{m_3} \times \sum (m_n \times z_n)$$

$$= \frac{1}{6.525} (0.88 \times 5 + 4.35 \times 42.5 + 0.795 \times 42.5 + 0.5 \times 42.5) = 37.4 \text{ mm}$$

4. Calculation of Load Factor for Static Load

m_3 : Mass

$m_3 \text{ max}$ (from (1) of graph MY1H/ m_3) = 50 (kg).....

$$\text{Load factor } \alpha_1 = m_3 / m_3 \text{ max} = 6.525 / 50 = 0.13$$

M_2 : Moment

$M_2 \text{ max}$ (from (2) of graph MY1H/ M_2) = 50 (N·m).....

$$M_2 = m_3 \times g \times Z = 6.525 \times 9.8 \times 37.4 \times 10^{-3} = 2.39 \text{ (N·m)}$$

$$\text{Load factor } \alpha_2 = M_2 / M_2 \text{ max} = 2.39 / 50 = 0.05$$

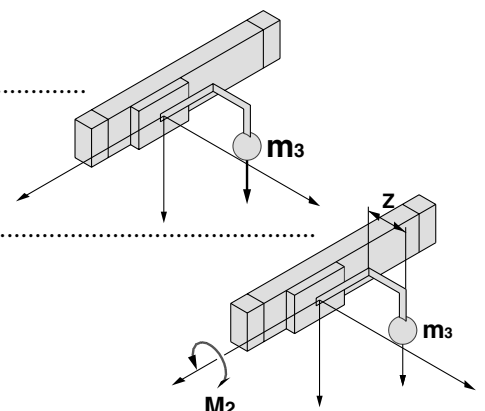

M₃: Moment

M₃ max (from (3) of graph MY1H/M₃) = 38.7 (N·m).....

M₃ = **m₃** × **g** × **X** = 6.525 × 9.8 × 138.5 × 10⁻³ = 8.86 (N·m)

Load factor **α₃** = **M₃**/**M₃ max** = 8.86/38.7 = **0.23**

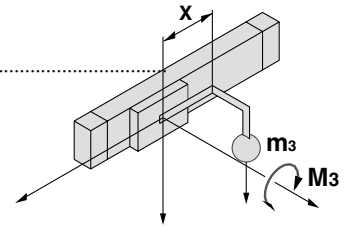

5. Calculation of Load Factor for Dynamic Moment

Equivalent load F_E at impact

$$F_E = 1.4 \nu a \times \delta \times m \times g = 1.4 \times 300 \times \frac{1}{100} \times 6.525 \times 9.8 = 268.6 \text{ (N)}$$

M_{1E}: Moment

M_{1E} max (from (4) of graph MY1H/M₁ where 1.4νa = 420 mm/s) = 35.9 (N·m).....

$$M_{1E} = \frac{1}{3} \times F_E \times Z = \frac{1}{3} \times 268.6 \times 37.4 \times 10^{-3} = 3.35 \text{ (N·m)}$$

Load factor **α₄** = **M_{1E}**/**M_{1E} max** = 3.35/35.9 = **0.09**

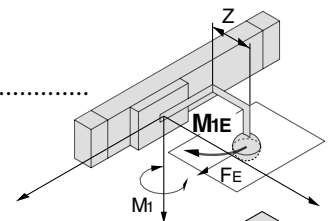

M_{3E}: Moment

M_{3E} max (from (5) of graph MY1H/M₃ where 1.4νa = 420 mm/s) = 27.6 (N·m).....

$$M_{3E} = \frac{1}{3} \times F_E \times Y = \frac{1}{3} \times 268.6 \times 29.6 \times 10^{-3} = 2.65 \text{ (N·m)}$$

Load factor **α₅** = **M_{3E}**/**M_{3E} max** = 2.65/27.6 = **0.10**

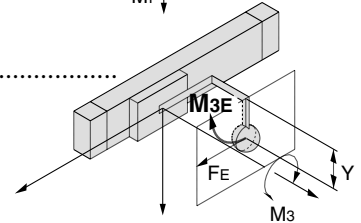

6. Sum and Examination of Guide Load Factors

$$\sum \alpha = \alpha_1 + \alpha_2 + \alpha_3 + \alpha_4 + \alpha_5 = 0.60 \leq 1$$

The above calculation is within the allowable value, and therefore the selected model can be used.

Select a shock absorber separately.

In an actual calculation, when the total sum of guide load factors $\sum \alpha$ in the formula above is more than 1, consider either decreasing the speed, increasing the bore size, or changing the product series.

This calculation can be easily made using the “SMC Pneumatics CAD System”.

MY1B

MY1M

MY1C

MY1H

MY1HT

MY1□W

MY2C

MY2H□

MY3A

MY3B

MY3M

Load Mass

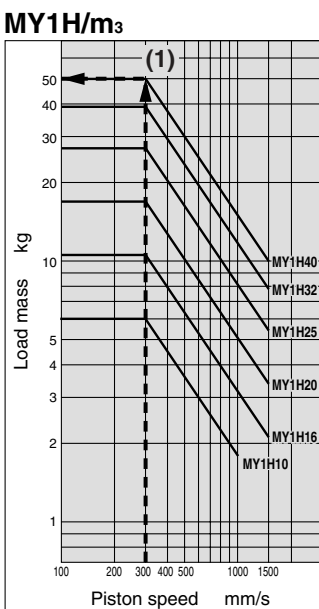

Allowable Moment

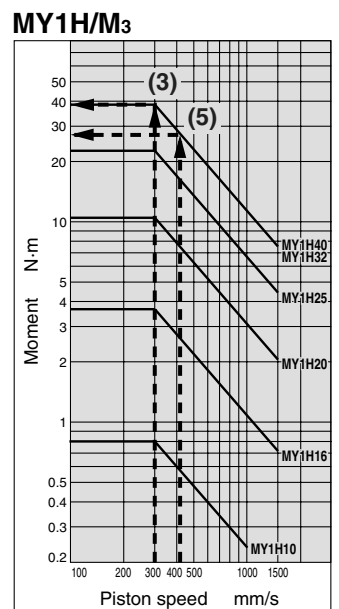
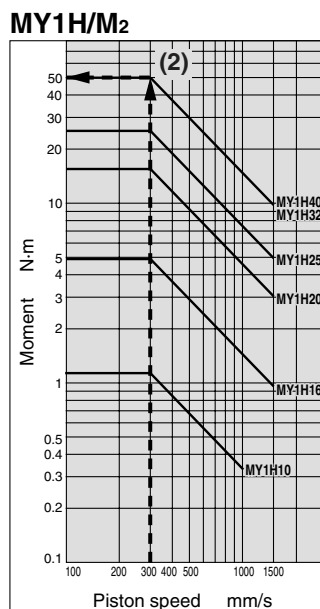
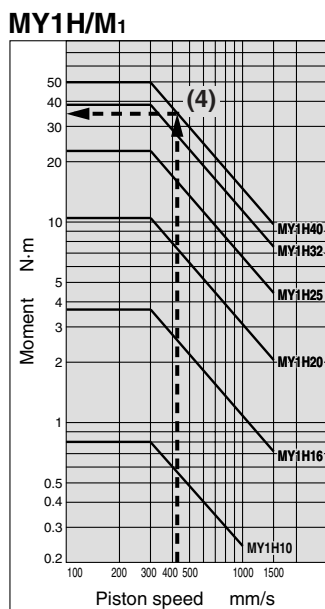

D-□

-X□

Individual
-X□

Technical
data

Mechanically Jointed Rodless Cylinder Linear Guide Type

Series MY1H

ø10, ø16, ø20, ø25, ø32, ø40

How to Order

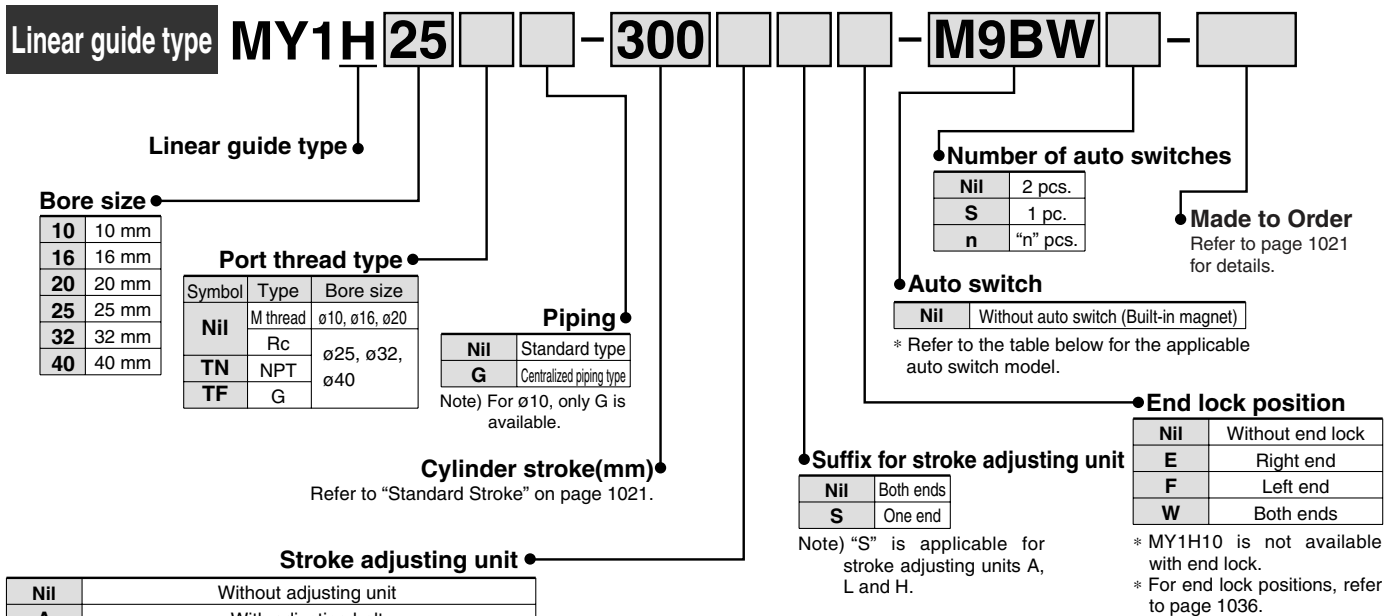

Shock Absorbers for L and H Units

Bore size (mm)	25	16	20	25	32	40
L unit	—	RB0806	RB1007	RB1412	RB2015	—
H unit	RB0805	—	RB1007	RB1412	RB2015	—

Note) MY1H16 is not available with H unit.
MY1H10 is not available with A and L units.

Applicable Auto Switch/Refer to pages 1263 to 1371 for further information on auto switches.

Type	Special function	Electrical entry	Indicator light	Wiring (Output)	Load voltage		Auto switch model		Lead wire length (m)					Pre-wired connector	Applicable load					
					DC	AC	Perpendicular	In-line	0.5 (Nil)	1 (M)	3 (L)	5 (Z)	None (N)							
Solid state switch	Diagnostic indication (2-color indication)	Grommet	Yes	3-wire (NPN)	24V	5V, 12V	—	M9NV	M9N	●	●	●	○	○	○	IC circuit	Relay, PLC			
				3-wire (PNP)				M9PV	M9P	●	●	●	○	○	○					
				2-wire				M9BV	M9B	●	●	●	○	○	○			○	—	
				3-wire (NPN)				M9NWV	M9NW	●	●	●	○	○	○			○	○	—
				3-wire (PNP)				M9PWV	M9PW	●	●	●	○	○	○			○	○	—
				2-wire				M9BWV	M9BW	●	●	●	○	○	○			○	○	—
Reed switch	—	Grommet	Yes	3-wire (NPN equivalent)	24V	12V	100V or less	A96V	A96	●	—	●	—	—	—	IC circuit	—			
				2-wire				A93V	A93	●	—	●	—	—	—	—	—	Relay, PLC		
				2-wire				A90V	A90	●	—	●	—	—	—	—	—	IC circuit		

* Lead wire length symbols: 0.5 m.....Nil(Example) M9NW
1 m.....M (Example) M9NWM
3 m.....L (Example) M9NWL
5 m.....Z (Example) M9NWZ

* Solid state auto switches marked with "○" are produced upon receipt of order.

* There are other applicable auto switches than listed above. For details, refer to page 1053.

* For details about auto switches with pre-wired connector, refer to pages 1328 and 1329.

* Auto switches are shipped together (not assembled).

Mechanically Jointed Rodless Cylinder Linear Guide Type **Series MY1H**

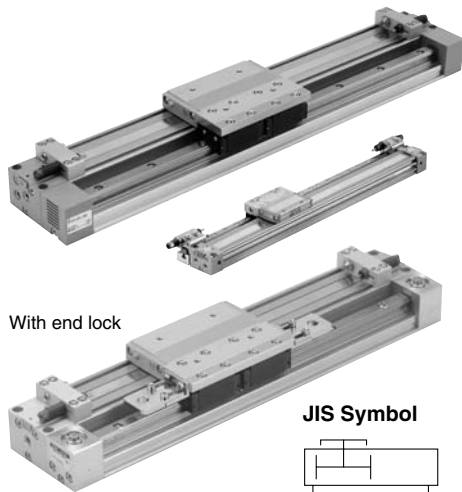

Specifications

Bore size (mm)	10	16	20	25	32	40
Fluid	Air					
Action	Double acting					
Operating pressure range	0.2 to 0.8 MPa (2.0 to 8.2 kgf/cm ²)		0.1 to 0.8 MPa			
Proof pressure	1.2 MPa					
Ambient and fluid temperature	5 to 60°C					
Cushion	Rubber bumper		Air cushion			
Lubrication	Non-lube					
Stroke length tolerance	+1.8 0					
Piping port size	Front/Side port	M5 x 0.8			Rc 1/8	Rc 1/4
	Bottom port	ø4		ø5	ø6	ø8

Stroke Adjusting Unit Specifications

Bore size (mm)	10			16			20			25			32			40		
Unit symbol	H	A	L	A	L	H	A	L	H	A	L	H	A	L	H			
Configuration	RB 0805	With adjusting bolt	RB 0806	With adjusting bolt	RB 0806	With adjusting bolt	With adjusting bolt	RB 1007	With adjusting bolt	RB 1007	With adjusting bolt	RB 1412	With adjusting bolt	RB 1412	With adjusting bolt			
Shock absorber model	with adjusting bolt		with adjusting bolt		with adjusting bolt			with adjusting bolt		with adjusting bolt		with adjusting bolt		with adjusting bolt				
Fine stroke adjustment range (mm)	0 to -10			0 to -5.6			0 to -6			0 to -11.5			0 to -12			0 to -16		
Stroke adjustment range	When exceeding the stroke fine adjustment range: Utilize a made-to-order specifications "-X416" and "-X417".																	

* Stroke adjustment range is applicable for one side when mounted on a cylinder.

Shock Absorber Specifications

Model	RB 0805	RB 0806	RB 1007	RB 1412	RB 2015
Max. energy absorption (J)	1.0	2.9	5.9	19.6	58.8
Stroke absorption (mm)	5	6	7	12	15
Max. collision speed (mm/s)	1000	1500	1500	1500	1500
Max. operating frequency (cycle/min)	80	80	70	45	25
Spring force (N)	Extended	1.96	1.96	4.22	6.86
	Retracted	3.83	4.22	6.86	15.98
Operating temperature range (°C)	5 to 60				

* The shock absorber service life is different from that of the MY1H cylinder depending on operating conditions. Refer to the RB Series Specific Product Precautions for the replacement period.

Standard Stroke

Bore size (mm)	Standard stroke * (mm)	Maximum manufacturable stroke (mm)
10, 16, 20	50, 100, 150, 200 250, 300, 350, 400	1000
25, 32, 40	450, 500, 550, 600	1500

* Strokes are manufacturable in 1 mm increments, up to the maximum stroke. However, add "-XB10" to the end of the part number for non-standard strokes from 51 to 599. Also when exceeding a 600 mm stroke, specify "-XB11" at the end of the model number. (Except ø10)



Made to Order Specifications (For details, refer to pages 1395 to 1565.)

Symbol	Specifications
-XB10	Intermediate stroke (Using exclusive body)
-XB11	Long stroke
-XC56	With knock pin hole
-XC67	NBR rubber lining in dust seal band
-X168	Helical insert thread specifications
-X416	Holder mounting bracket I
-X417	Holder mounting bracket II

Piston Speed

Bore size (mm)	10	16 to 40
Without stroke adjusting unit	100 to 500 mm/s	100 to 1000 mm/s
Stroke adjusting unit	A unit	100 to 200 mm/s
	L unit and H unit	100 to 1000 mm/s

Note 1) Be aware that when the stroke adjusting range is increased by manipulating the adjusting bolt, the air cushion capacity decreases. Also, when exceeding the air cushion stroke ranges on page 1023, **the piston speed should be 100 to 200 mm per second.**

Note 2) The piston speed is 100 to 1000 mm/s for centralized piping.

Note 3) Use at a speed within the absorption capacity range. Refer to page 1023.

Lock Specifications

Bore size (mm)	16	20	25	32	40
Lock position	One end (Selectable), Both ends				
Holding force (Max.) (N)	110	170	270	450	700
Fine stroke adjusting range (mm)	0 to -5.6	0 to -6	0 to -11.5	0 to -12	0 to -16
Backlash	1 mm or less				
Manual release	Possible (Non-lock type)				

MY1B

MY1M

MY1C

MY1H

MY1HT

MY1□W

MY2C

MY2H□

MY3A

MY3B

MY3M

D-□

-X□

Individual

-X□

Technical data

Series MY1H

Theoretical Output

Bore size (mm)	Piston area (mm ²)	Operating pressure (MPa)						
		0.2	0.3	0.4	0.5	0.6	0.7	0.8
10	78	15	23	31	39	46	54	62
16	200	40	60	80	100	120	140	160
20	314	62	94	125	157	188	219	251
25	490	98	147	196	245	294	343	392
32	804	161	241	322	402	483	563	643
40	1256	251	377	502	628	754	879	1005

(N)
Note) Theoretical output (N) = Pressure (MPa) x Piston area (mm²)

Mass

Bore size (mm)	Basic mass	Additional mass per each 50mm of stroke	Side support mass (per set) Type A and B	Stroke adjusting unit mass (per unit)		
				A unit mass	L unit mass	H unit mass
10	0.26	0.08	0.003	—	—	0.02
16	0.74	0.14	0.01	0.02	0.04	—
20	1.35	0.25	0.02	0.03	0.05	0.07
25	2.31	0.30	0.02	0.04	0.07	0.11
32	4.65	0.46	0.04	0.08	0.14	0.23
40	6.37	0.55	0.08	0.12	0.19	0.28

Calculation: (Example) MY1H25-300A

- Basic mass 2.31 kg
 - Additional mass 0.30/50 st
 - Mass of A unit 0.06 kg
 - Cylinder stroke.....300 st
- $$2.31 + 0.30 \times 300 \div 50 + 0.04 \times 2 \cong 4.19 \text{ kg}$$

Option

Stroke Adjusting Unit Part No.

Unit no.		Bore (mm)	10	16	20	25	32	40
A unit	Left	—	—	MYH-A16A1	MYH-A20A1	MYH-A25A1	MYH-A32A1	MYH-A40A1
	Right	—	—	MYH-A16A2	MYH-A20A2	MYH-A25A2	MYH-A32A2	MYH-A40A2
L unit	Left	—	—	MYH-A16L1	MYH-A20L1	MYH-A25L1	MYH-A32L1	MYH-A40L1
	Right	—	—	MYH-A16L2	MYH-A20L2	MYH-A25L2	MYH-A32L2	MYH-A40L2
H unit	Left	MYH-A10H1	—	—	MYH-A20H1	MYH-A25H1	MYH-A32H1	MYH-A40H1
	Right	MYH-A10H2	—	—	MYH-A20H2	MYH-A25H2	MYH-A32H2	MYH-A40H2

Stroke adjusting unit form and mounting direction

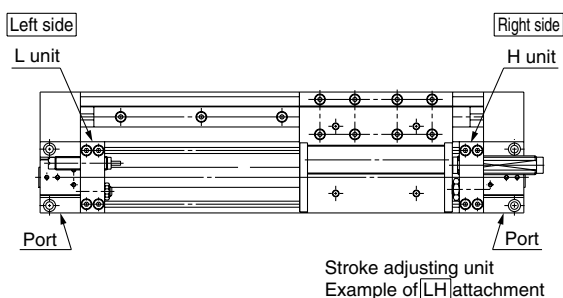

Side Support Part No.

Type	Bore (mm)	10	16	20	25	32	40
Side support A	—	MY-S10A	MY-S16A	MY-S20A	MY-S25A	MY-S32A	MY-S40A
Side support B	—	MY-S10B	MY-S16B	MY-S20B	MY-S25B	MY-S32B	MY-S40B

For details about dimensions, etc., refer to page 1037.

A set of side supports consists of a left support and a right support.

Cushion Capacity

Cushion Selection

<Rubber bumper>

Rubber bumpers are a standard feature on MY1H10.

Since the stroke absorption of rubber bumpers is short, when adjusting the stroke with an A unit, install an external shock absorber.

The load and speed range which can be absorbed by a rubber bumper is inside the rubber bumper limit line of the graph.

<Air cushion>

Air cushions are a standard feature on mechanically jointed rodless cylinders.

The air cushion mechanism is incorporated to prevent excessive impact of the piston at the stroke end during high speed operation. The purpose of air cushion, thus, is not to decelerate the piston near the stroke end.

The ranges of load and speed that air cushions can absorb are within the air cushion limit lines shown in the graphs.

<Stroke adjusting unit with shock absorber>

Use this unit when operating with a load or speed exceeding the air cushion limit line, or when cushioning is required outside of the effective air cushion stroke range due to stroke adjustment.

L unit

Use this unit when the cylinder stroke is outside of the effective air cushion range even if the load and speed are within the air cushion limit line, or when the cylinder is operated in a load and speed range above the air cushion limit line or below the L unit limit line.

H unit

Use this unit when the cylinder is operated in a load and speed range above the L unit limit line and below the H unit limit line.

⚠ Caution

1. Refer to the figure below when using the adjusting bolt to perform stroke adjustment.

When the effective stroke of the shock absorber decreases as a result of stroke adjustment, the absorption capacity decreases dramatically. Secure the adjusting bolt at the position where it protrudes approximately 0.5 mm from the shock absorber.

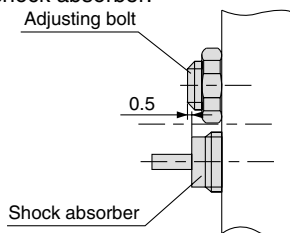

2. Do not use a shock absorber together with air cushion.

Air Cushion Stroke (mm)

Bore size (mm)	Cushion stroke
16	12
20	15
25	15
32	19
40	24

Absorption Capacity of Rubber Bumper, Air cushion and Stroke Adjusting Units

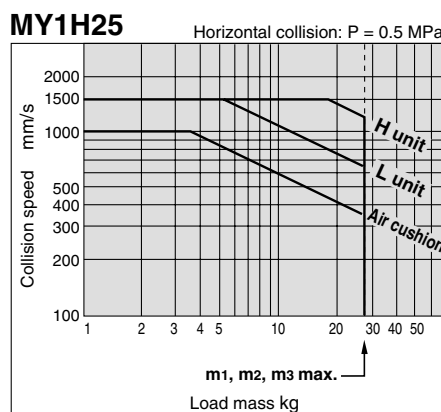
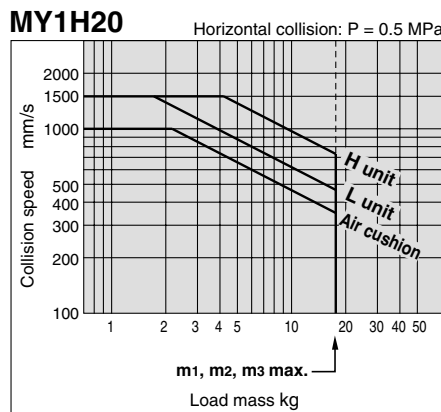
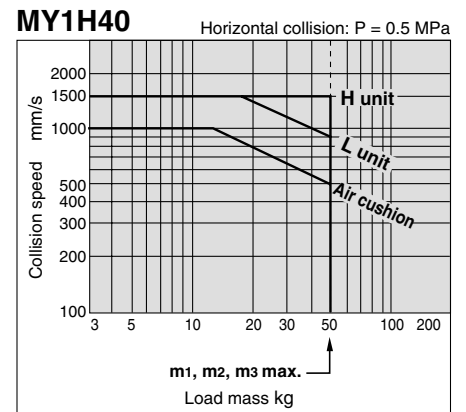
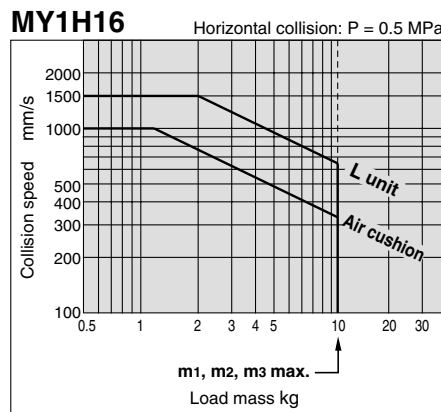
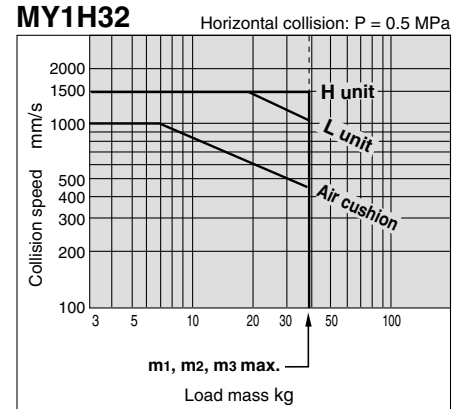
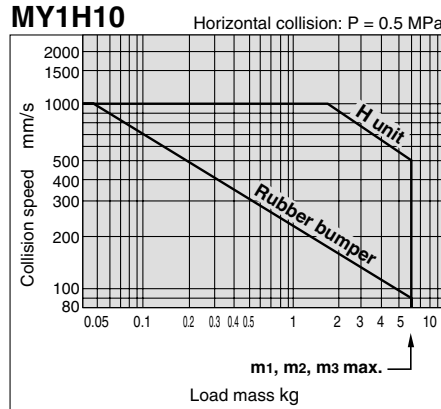

MY1B

MY1M

MY1C

MY1H

MY1HT

MY1□W

MY2C

MY2H□

MY3A

MY3B

MY3M

D-□

-X□

Individual

-X□

Technical data

Series MY1H

Cushion Capacity

Tightening Torque for Stroke Adjusting Unit Holding Bolts (N·m)

Bore size (mm)	Tightening torque
10	Refer to the adjusting procedures on page 1025.
16	0.7
20	1.8
25	1.8
32	3.5
40	5.8

Calculation of Absorbed Energy for Stroke Adjusting Unit with Shock Absorber (N·m)

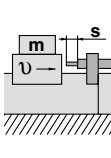
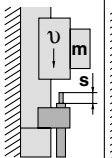
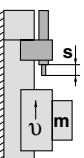
Type of impact	Horizontal collision	Vertical (Downward)	Vertical (Upward)
			
Kinetic energy E_1	$\frac{1}{2} m \cdot v^2$		
Thrust energy E_2	$F \cdot s$	$F \cdot s + m \cdot g \cdot s$	$F \cdot s - m \cdot g \cdot s$
Absorbed energy E	$E_1 + E_2$		

Symbol

v : Speed of impact object (m/s)

F : Cylinder thrust (N)

s : Shock absorber stroke (m)

m : Mass of impact object (kg)

g : Gravitational acceleration (9.8 m/s²)

Note) The speed of the impact object is measured at the time of impact with the shock absorber.

Rubber Bumper (ø10 only) Positive Stroke from One End Due to Pressure

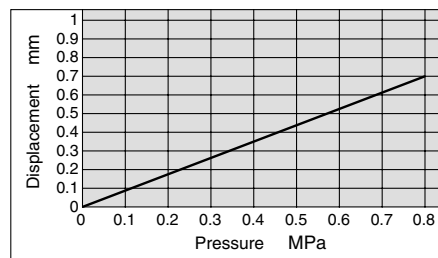



Series MY1H Specific Product Precautions 1

Be sure to read before handling.

Refer to front matters 54 and 55 for Safety Instructions and pages 3 to 11 for Actuator and Auto Switch Precautions.

⚠ Caution

Use caution not to get your hands caught in the unit.

- When using a product with stroke adjusting unit, the space between the slide table (slider) and the stroke adjusting unit becomes narrow at the stroke end, causing a danger of hands getting caught. Install a protective cover to prevent direct contact with the human body.

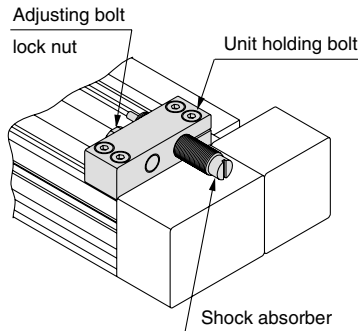

<Fastening of unit>

The unit can be secured by evenly tightening the four unit holding bolts.

⚠ Caution

Do not operate with the stroke adjusting unit fixed in an intermediate position.

When the stroke adjusting unit is fixed in an intermediate position, slippage can occur depending on the amount of energy released at the time of an impact. In such cases, the use of the adjusting bolt mounting brackets, available per made-to-order specifications -X416 and -X417, is recommended. (Except $\phi 10$) For other lengths, please consult with SMC (Refer to "Tightening Torque for Stroke Adjusting Unit Holding Bolts".)

<Stroke adjustment with adjusting bolt>

Loosen the adjusting bolt lock nut, and adjust the stroke from the head cover side using a hexagon wrench. Re-tighten the lock nut.

<Stroke adjustment with shock absorber>

Loosen the two unit holding bolts on the shock absorber side, turn the shock absorber and adjust the stroke. Then, uniformly tighten the unit holding bolts to secure the shock absorber.

Take care not to over-tighten the holding bolts. (Except $\phi 10$, $\phi 16$, $\phi 20$) (Refer to "Tightening Torque for Stroke Adjusting Unit Holding Bolts".)

⚠ Caution

To adjust the stroke adjusting unit of the MY1H10, follow the step shown below.

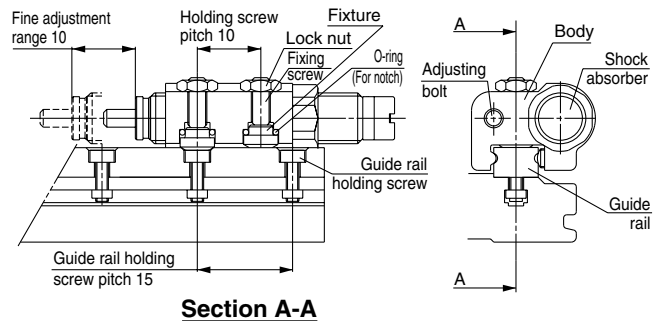

Adjusting Procedure

- Loosen the two lock nuts, and then loosen the holding screws by turning them approximately two turns.
- Move the body to the notch just before the desired stroke. (The notches are found in alternating increments of 5 mm and 10 mm.)
- Tighten the holding screw to 0.3 N·m. Make sure that the tightening does not cause excessive torque. The fixture fits into the fastening hole in the guide rail to prevent slippage, which enables fastening with low torque.
- Tighten the lock nut to 0.6 N·m.
- Make fine adjustments with the adjusting bolt and shock absorber.

MY1B

MY1M

MY1C

MY1H

MY1HT

MY1□W

MY2C

MY2H□

MY3A

MY3B

MY3M

D-□

-X□

Individual

-X□

Technical data



Series MY1H

Specific Product Precautions 2

Be sure to read before handling.

Refer to front matters 54 and 55 for Safety Instructions and pages 3 to 11 for Actuator and Auto Switch Precautions.

With End Locks

Recommended Pneumatic Circuit

Caution

This is necessary for the correct locking and unlocking actions.

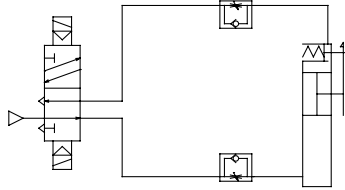

Operating Precautions

Caution

1. Do not use 3 position solenoid valves.

Avoid use in combination with 3 position solenoid valves (especially closed center metal seal types). If pressure is trapped in the port on the lock mechanism side, the cylinder cannot be locked.

Furthermore, even after being locked, the lock may be released after some time due to air leaking from the solenoid valve and entering the cylinder.

2. Back pressure is required when releasing the lock.

Before starting operation, be sure to control the system so that air is supplied to the side without the lock mechanism (in case of locks on both ends, the side where the slide table is not locked) as shown in the figure above. There is a possibility that the lock may not be released. (Refer to the section on releasing the lock.)

3. Release the lock when mounting or adjusting the cylinder.

If mounting or other work is performed when the cylinder is locked, the lock unit may be damaged.

4. Operate at 50% or less of the theoretical output.

If the load exceeds 50% of the theoretical output, this may cause problems such as failure of the lock to release, or damage to the lock unit.

5. Do not operate multiple cylinders in synchronization.

Avoid applications in which two or more end lock cylinders are synchronized to move one workpiece, as one of the cylinder locks may not be able to release when required.

6. Use a speed controller with meter-out control.

Lock cannot be released occasionally by meter-in control.

7. Be sure to operate completely to the cylinder stroke end on the side with the lock.

If the cylinder piston does not reach the end of the stroke, locking and unlocking may not be possible. (Refer to the section on adjusting the end lock mechanism.)

Operating Pressure

Caution

1. Supply air pressure of 0.15 MPa or higher to the port on the side that has the lock mechanism, as it is necessary for disengaging the lock.

Exhaust Speed

Caution

1. Locking will occur automatically if the pressure applied to the port on the lock mechanism side falls to 0.05 MPa or less. In the cases where the piping on the lock mechanism side is long and thin, or the speed controller is separated at some distance from the cylinder port, the exhaust speed will be reduced. Take note that some time may be required for the lock to engage. In addition, clogging of a silencer mounted on the solenoid valve exhaust port can produce the same effect.

Relation to Cushion

Caution

1. When the air cushion on the lock mechanism side is in a fully closed or nearly closed state, there is a possibility that the slide table will not reach the stroke end, in which case locking will not occur.

Adjusting the End Lock Mechanism

Caution

1. The end lock mechanism is adjusted at the time of shipping. Therefore, adjustment for operation at the stroke end is unnecessary.

2. Adjust the end lock mechanism after the stroke adjusting unit has been adjusted. The adjusting bolt and shock absorber of the stroke adjusting unit must be adjusted and secured first. Locking and unlocking may not occur otherwise.

3. Perform fine adjustment of the end lock mechanism as follows. Loosen the lock finger holding bolts, and then adjust by aligning the center of the lock piston with the center of the lock finger hole. Secure the lock finger.

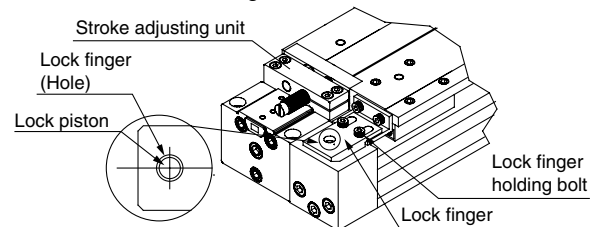

Releasing the Lock

Warning

1. Before releasing the lock, be sure to supply air to the side without the lock mechanism, so that there is no load applied to the lock mechanism when it is released. (Refer to the recommended pneumatic circuits.) If the lock is released when the port on the side without the lock is in an exhaust state, and with a load applied to the lock unit, the lock unit may be subjected to an excessive force and be damaged.

Furthermore, sudden movement of the slide table is very dangerous.

Manual Release

Caution

1. When manually releasing the end lock, be sure to release the pressure.

If it is unlocked while the air pressure still remains, it will lead to damage a workpiece, etc. due to unexpected lurching.

2. Perform manual release of the end lock mechanism as follows. Push the lock piston down with a screwdriver, etc., and move the slide table.

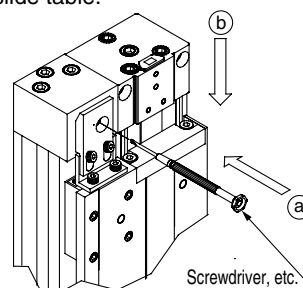

Other handling precautions regarding mounting, piping, and environment are the same as the standard series.

Construction: $\phi 10$

Centralized piping type

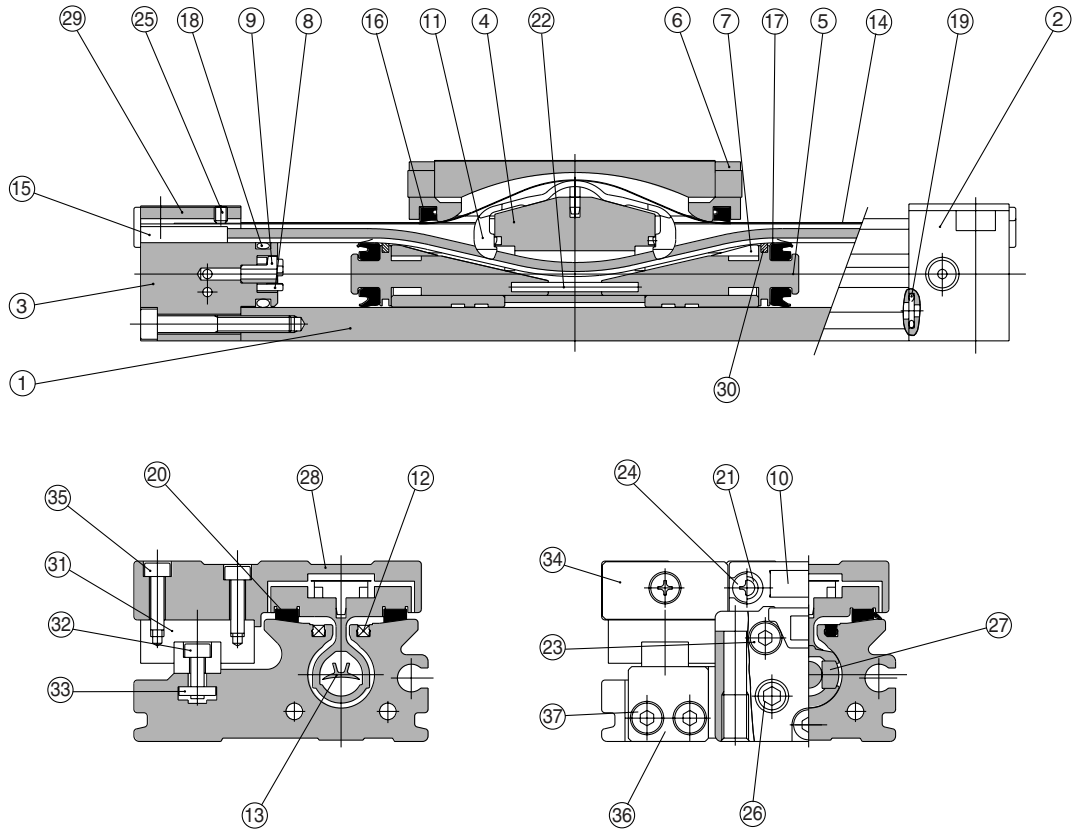

- MY1B
- MY1M
- MY1C
- MY1H**
- MY1HT
- MY1□W
- MY2C
- MY2H□
- MY3A
- MY3B
- MY3M

Component Parts

No.	Description	Material	Note
1	Cylinder tube	Aluminum alloy	Hard anodized
2	Head cover WR	Aluminum alloy	Painted
3	Head cover WL	Aluminum alloy	Painted
4	Piston yoke	Aluminum alloy	Hard anodized
5	Piston	Aluminum alloy	Chromated
6	End cover	Special resin	
7	Wear ring	Special resin	
8	Bumper	Polyurethane rubber	
9	Holder	Stainless steel	
10	Stopper	Carbon steel	Nickel plated
11	Belt separator	Special resin	
12	Seal magnet	Rubber magnet	
15	Belt clamp	Special resin	
20	Bearing	Special resin	
21	Spacer	Chromium molybdenum steel	Nickel plated

No.	Description	Material	Note
22	Spring pin	Stainless steel	
23	Hexagon socket head cap screw	Chromium molybdenum steel	Nickel plated
24	Round head Phillips screw	Carbon steel	Nickel plated
25	Hexagon socket head set screw	Carbon steel	Black zinc chromated
26	Hexagon socket head plug	Carbon steel	Nickel plated
27	Magnet	—	
28	Slide table	Aluminum alloy	Hard anodized
29	Head plate	Stainless steel	
30	Felt	Felt	
31	Linear guide	—	
32	Hexagon socket head cap screw	Chromium molybdenum steel	Nickel plated
33	Square nut	Carbon steel	Nickel plated
34	Stopper plate	Carbon steel	Nickel plated
35	Hexagon socket head cap screw	Chromium molybdenum steel	Nickel plated
36	Guide stopper	Carbon steel	Nickel plated
37	Hexagon socket head cap screw	Chromium molybdenum steel	Nickel plated

Replacement Part: Seal Kit

No.	Description	Qty.	MY1H10
13	Seal belt	1	MY10-16A-Stroke
14	Dust seal band	1	MY10-16B-Stroke
16	Scraper	2	MY1B10-PS
17	Piston seal	2	
18	Tube gasket	2	
19	O-ring	4	

* Seal kit includes 16, 17, 18 and 19.
 Seal kit includes a grease pack (10 g).
 When 13 and 14 are shipped independently, a grease pack is included.
 Order with the following part number when only the grease pack is needed.
Grease pack part number: GR-S-010 (10 g), GR-S-020 (20 g)

- D-□
- X□
- Individual -X□
- Technical data

Series MY1H

Construction: $\varnothing 16$ to $\varnothing 40$

MY1H16 to 40

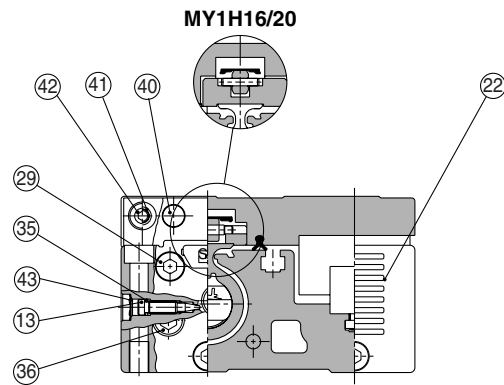
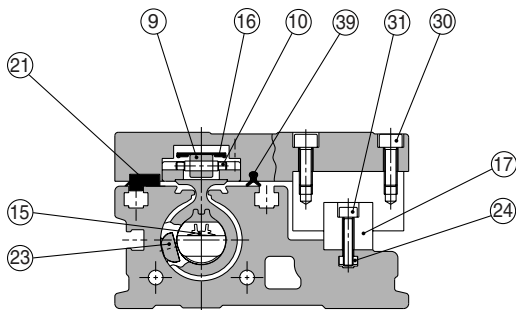
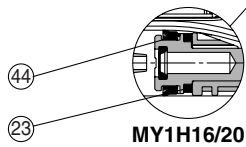
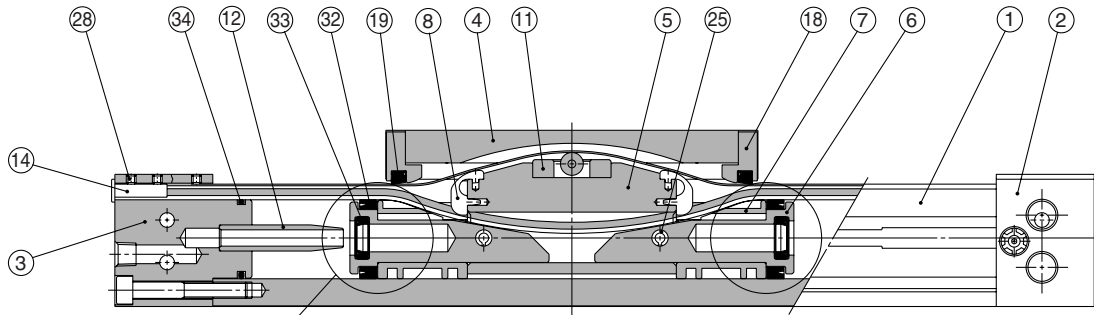

MY1H16 to 40

Component Parts

No.	Description	Material	Note
1	Cylinder tube	Aluminum alloy	Hard anodized
2	Head cover WR	Aluminum alloy	Painted
3	Head cover WL	Aluminum alloy	Painted
4	Slide table	Aluminum alloy	Hard anodized
5	Piston yoke	Aluminum alloy	Chromated
6	Piston	Aluminum alloy	Chromated
7	Wear ring	Special resin	
8	Belt separator	Special resin	
9	Guide roller	Special resin	
10	Guide roller shaft	Stainless steel	
11	Coupler	Sintered iron material	
12	Cushion ring	Brass	
13	Cushion needle	Rolled steel	Nickel plated
14	Belt clamp	Special resin	
17	Guide	—	
18	End cover	Special resin	
21	Bearing	Special resin	
22	Guide cover	Special resin	

No.	Description	Material	Note
23	Magnet	—	
24	Square nut	Carbon steel	Nickel plated
25	Spring pin	Carbon tool steel	Black zinc chromated
28	Hexagon socket head set screw	Chromium molybdenum steel	Black zinc chromated/Nickel plated
29	Hexagon socket head cap screw	Chromium molybdenum steel	Nickel plated
30	Hexagon socket head cap screw	Chromium molybdenum steel	Nickel plated
31	Hexagon socket head cap screw	Chromium molybdenum steel	Nickel plated
36	Hexagon socket head taper plug	Carbon steel	Nickel plated
38	Hexagon socket head taper plug	Carbon steel	Nickel plated
40	Stopper	Carbon steel	Nickel plated
41	Spacer	Stainless steel	
42	Hexagon socket button head screw	Chromium molybdenum steel	Nickel plated
43	Type CR retaining ring	Spring steel	
44	Lube retainer	Special resin	(ø16, ø20)

Replacement Part: Seal Kit

No.	Description	Qty.	MY1H16	MY1H20	MY1H25	MY1H32	MY1H40
15	Seal belt	1	MY16-16A- Stroke	MY20-16A- Stroke	MY25-16A- Stroke	MY32-16A- Stroke	MY40-16A- Stroke
16	Dust seal band	1	MY16-16B- Stroke	MY20-16B- Stroke	MY25-16B- Stroke	MY32-16B- Stroke	MY40-16B- Stroke
35	O-ring	2	ø4 x ø1.8 x ø1.1	ø4 x ø1.8 x ø1.1	ø5.1 x ø3 x ø1.05	ø7.15 x ø3.75 x ø1.7	ø7.15 x ø3.75 x ø1.7
39	Side scraper	1	MYH16-15BK2900B	MYH20-15BK2901B	MYH25-15BK2902B	MYH32-15BK2903B	MYH40-15BK2904B
19	Scraper	2					
32	Piston seal	2					
33	Cushion seal	2	MY1H16-PS	MY1H20-PS	MY1H25-PS	MY1H32-PS	MY1H40-PS
34	Tube gasket	2					
37	O-ring	4					

* Seal kit includes 19, 32, 33, 34 and 37. Order the seal kit based on each bore size.

* Seal kit includes a grease pack (10 g).

When 15 and 16 are shipped independently, a grease pack (20 g) is included.

Order with the following part number when only the grease pack is needed.

Grease pack part number: GR-S-010 (10 g), GR-S-020 (20 g)

Note) Two kinds of dust seal bands are available. Verify the type to use, since the part number varies depending on the treatment of the hexagon socket head set screw 28.

A: Black zinc chromated → MY□□-16B-stroke, B: Nickel plated → MY□□-16BW-stroke

MY1B

MY1M

MY1C

MY1H

MY1HT

MY1□W

MY2C

MY2H□

MY3A

MY3B

MY3M

D-□

-X□

Individual

-X□

Technical data

Series MY1H

Construction: $\varnothing 16$ to $\varnothing 40$

With End Lock

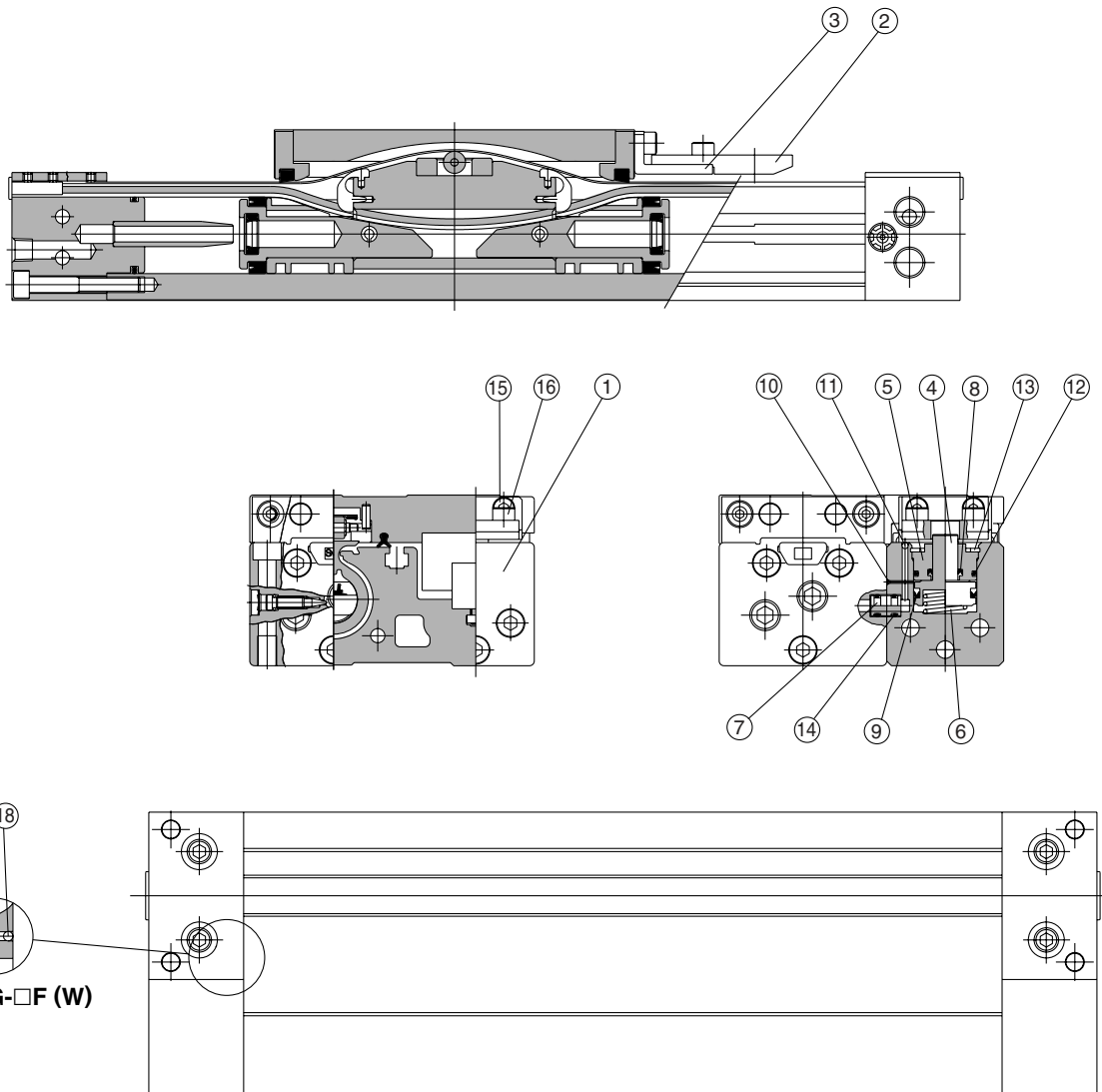

Component Parts

No.	Description	Material	Note
1	Locking body	Aluminum alloy	Painted
2	Lock finger	Carbon steel	After quenching, nickel plated
3	Lock finger bracket	Rolled steel	Nickel plated
4	Lock piston	Carbon tool steel	After quenching, electroless nickel plated
5	Rod cover	Aluminum alloy	Hard anodized
6	Return spring	Spring steel	Zinc chromated
7	Bypass pipe	Aluminum alloy	Chromated
10	Steel ball	High carbon chrome bearing steel	
11	Steel ball	High carbon chrome bearing steel	
13	Round type R retaining ring	Carbon tool steel	Nickel plated
14	O-ring	NBR	
15	Hexagon socket head cap screw	Chromium molybdenum steel	Nickel plated
16	Hexagon socket head cap screw	Chromium molybdenum steel	Nickel plated
17	Steel ball	High carbon chrome bearing steel	
18	Steel ball	High carbon chrome bearing steel	

Replacement Part: Seal Kit

No.	Description	Material	Qty.	MY1H16	MY1H20	MY1H25	MY1H32	MY1H40
8	Rod seal	NBR	1	DYR-4K	DYR-4K	DYR-8K	DYR-8K	DYR-8K
9	Piston seal	NBR	1	DYP-12	DYP-12	DYP-20	DYP-20	DYP-20
12	O-ring	NBR	1	C9	C9	C18	C18	C18

** Since the seal kit does not include a grease pack, order it separately.

Grease pack part no.: GR-S-010 (10 g)

Centralized Piping Type $\phi 10$

Refer to page 1056 regarding centralized piping port variations.

MY1H10G — Stroke

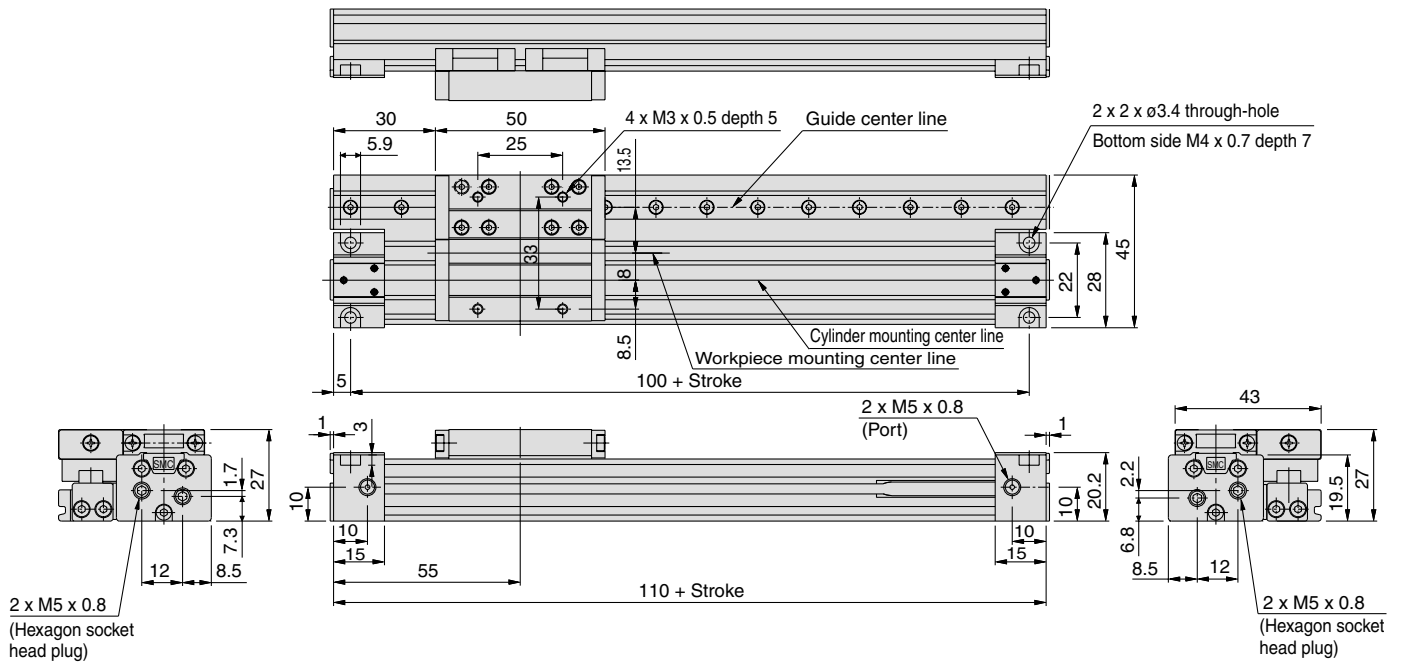

- MY1B
- MY1M
- MY1C
- MY1H**
- MY1HT
- MY1□W
- MY2C
- MY2H□
- MY3A
- MY3B
- MY3M

With shock absorber + Adjusting bolt

MY1H10G — Stroke H

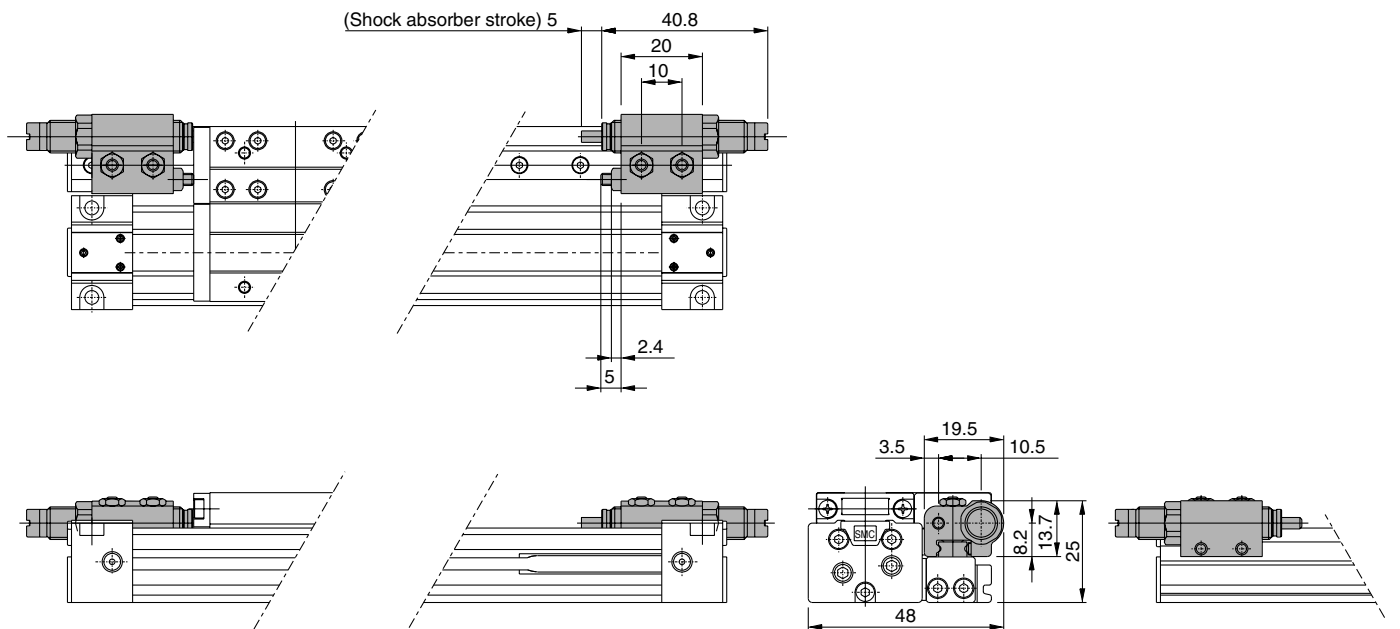

- D-□
- X□
- Individual -X□
- Technical data

Series MY1H

Standard Type/Centralized Piping Type $\phi 16, \phi 20$

Refer to page 1056 regarding centralized piping port variations.

MY1H16□/20□ - Stroke

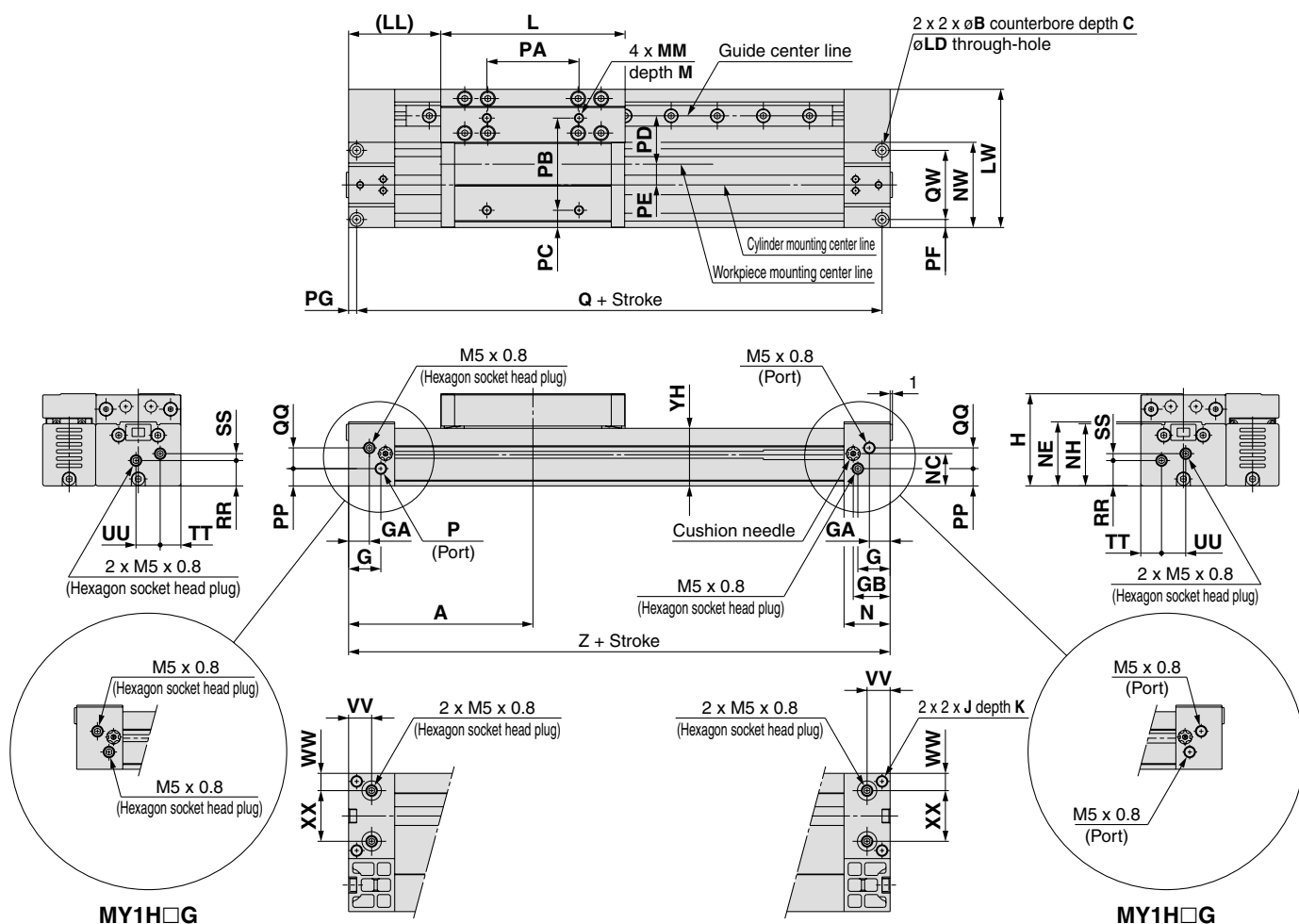

(mm)

Model	A	B	C	G	GA	GB	H	J	K	L	LD	LL	LW	M	MM	N	NC	NE	NH	NW
MY1H16□	80	6	3.5	14	9	16	40	M5 x 0.8	10	80	3.5	40	60	7	M4 x 0.7	20	14	27.8	27	37
MY1H20□	100	7.5	4.5	12.5	12.5	17.5	46	M6 x 1	12	100	4.5	50	78	8	M5 x 0.8	25	17.5	34	33.5	45

(mm)

Model	PA	PB	PC	PD	PE	PF	PG	PP	Q	QQ	QW	RR	SS	TT	UU	VV	WW	XX	YH	Z
MY1H16□	40	40	7.5	21	9	3.5	3.5	7.5	153	9	30	11	3	9	10.5	10	7.5	22	25	160
MY1H20□	50	40	14.5	27	12	4.5	4.5	11.5	191	11	36	14.5	5	10.5	12	12.5	10.5	24	31.5	200

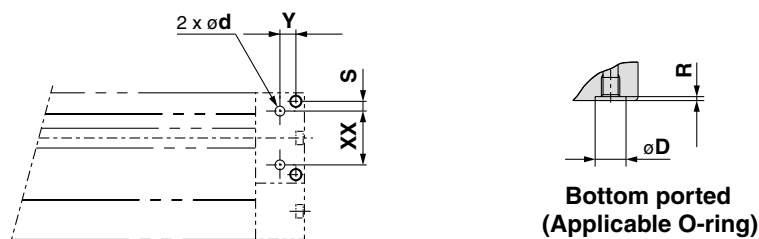

Hole Size for Centralized Piping on the Bottom

Model	WX	Y	S	d	D	R	Applicable O-ring
MY1H16□	22	6.5	4	4	8.4	1.1	C6
MY1H20□	24	8	6	4	8.4	1.1	

(Machine the mounting side to the dimensions below.)

Mechanically Jointed Rodless Cylinder Linear Guide Type **Series MY1H**

Standard Type/Centralized Piping Type $\phi 25, \phi 32, \phi 40$ Refer to page 1056 regarding centralized piping port variations.

MY1H25□/32□/40□ – Stroke

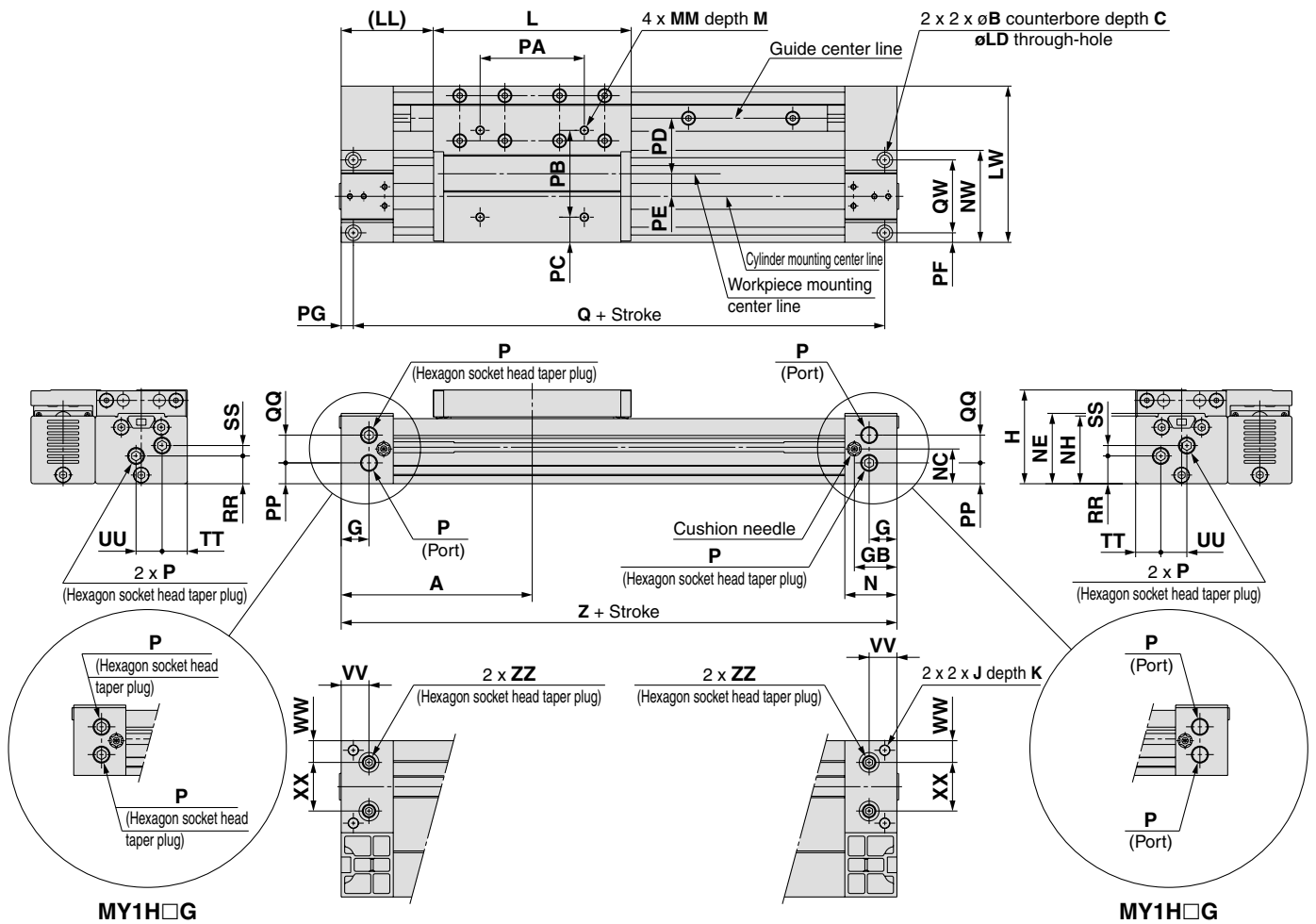

Model	A	B	C	G	GB	H	J	K	L	LD	LL	LW	M	MM	N	NC	NE	NH	NW	P
MY1H25□	110	9	5.5	16	24.5	54	M6 x 1	9.5	114	5.4	53	90	9	M5 x 0.8	30	20	40.5	39	53	Rc 1/8
MY1H32□	140	11	6.6	19	30	68	M8 x 1.25	16	140	6.8	70	110	13	M6 x 1	37	25	50	49	64	Rc 1/8
MY1H40□	170	14	8.5	23	36.5	84	M10 x 1.5	15	170	8.6	85	121	13	M6 x 1	45	30.5	63	61.5	75	Rc 1/4

"P" indicates cylinder supply ports.

Model	PA	PB	PC	PD	PE	PF	PG	PP	Q	QQ	QW	RR	SS	TT	UU	VV	WW	XX	YH	Z	ZZ
MY1H25□	60	50	14.5	32	13	5.5	7	12	206	16	42	16	6	14.5	15	16	12.5	28	37.5	220	Rc 1/16
MY1H32□	80	60	15	42	13	6.5	8	17	264	16	51	23	4	16	16	19	16	32	47	280	Rc 1/16
MY1H40□	100	80	20.5	37.5	23	8	9	18.5	322	24	59	27	10.5	20	22	23	19.5	36	59.5	340	Rc 1/8

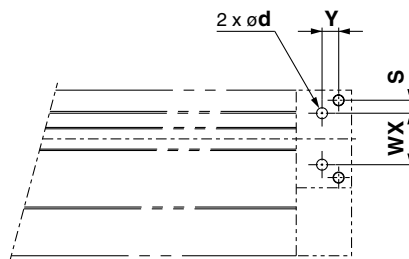

**Bottom ported (ZZ)
(Applicable O-ring)**

Hole Size for Centralized Piping on the Bottom

Model	WX	Y	S	d	D	R	Applicable O-ring
MY1H25□	28	9	7	6	11.4	1.1	C9
MY1H32□	32	11	9.5	6	11.4	1.1	
MY1H40□	36	14	11.5	8	13.4	1.1	

(Machine the mounting side to the dimensions below.)

- MY1B
- MY1M
- MY1C
- MY1H
- MY1HT
- MY1□W
- MY2C
- MY2H□
- MY3A
- MY3B
- MY3M

- D-□
- X□
- Individual -X□
- Technical data

Series MY1H

Stroke Adjusting Unit

With adjusting bolt

MY1H Bore size – Stroke A

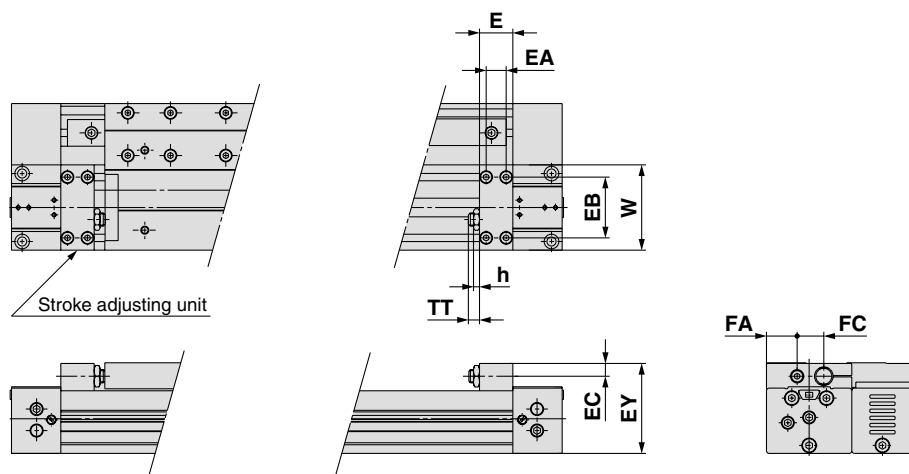

Applicable bore size	E	EA	EB	EC	EY	FA	FC	h	TT	W
MY1H16	14.6	7	28	5.8	39.5	11.5	13	3.6	5.4 (Max. 11)	37
MY1H20	19	10	33	5.8	45.5	15	14	3.6	6 (Max. 12)	45
MY1H25	18	9	40	7.5	53.5	16	21	3.5	5 (Max. 16.5)	53
MY1H32	25	14	45.6	9.5	67.5	23	20	4.5	8 (Max. 20)	64
MY1H40	31	19	55	11	82	24.5	26	4.5	9 (Max. 25)	75

With low load shock absorber + Adjusting bolt

MY1H Bore size – Stroke L

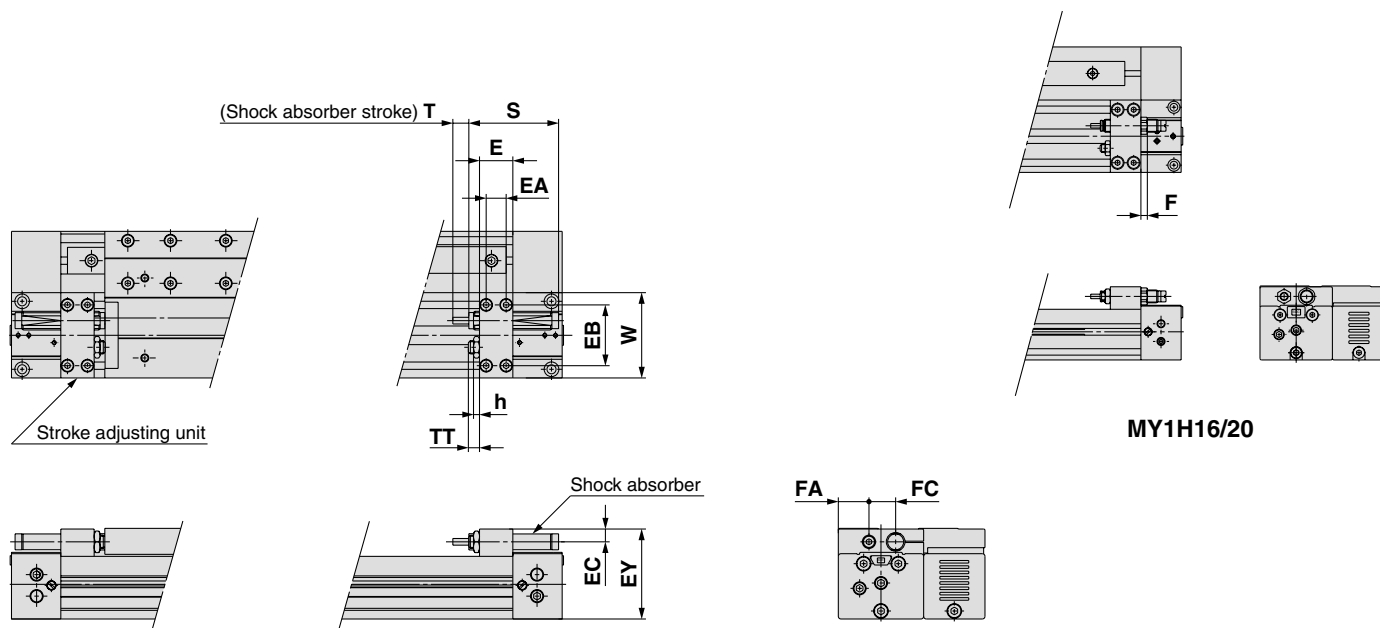

MY1H16/20

(mm)

Applicable bore size	E	EA	EB	EC	EY	F	FA	FC	h	S	T	TT	W	Shock absorber model
MY1H16	14.6	7	28	5.8	39.5	4	11.5	13	3.6	40.8	6	5.4 (Max. 11)	37	RB0806
MY1H20	19	10	33	5.8	45.5	4	15	14	3.6	40.8	6	6 (Max. 12)	45	RB0806
MY1H25	18	9	40	7.5	53.5	—	16	21	3.5	46.7	7	5 (Max. 16.5)	53	RB1007
MY1H32	25	14	45.6	9.5	67.5	—	23	20	4.5	67.3	12	8 (Max. 20)	64	RB1412
MY1H40	31	19	55	11	82	—	24.5	26	4.5	67.3	12	9 (Max. 25)	75	RB1412

Stroke Adjusting Unit

With high load shock absorber + Adjusting bolt

MY1H Bore size – Stroke H

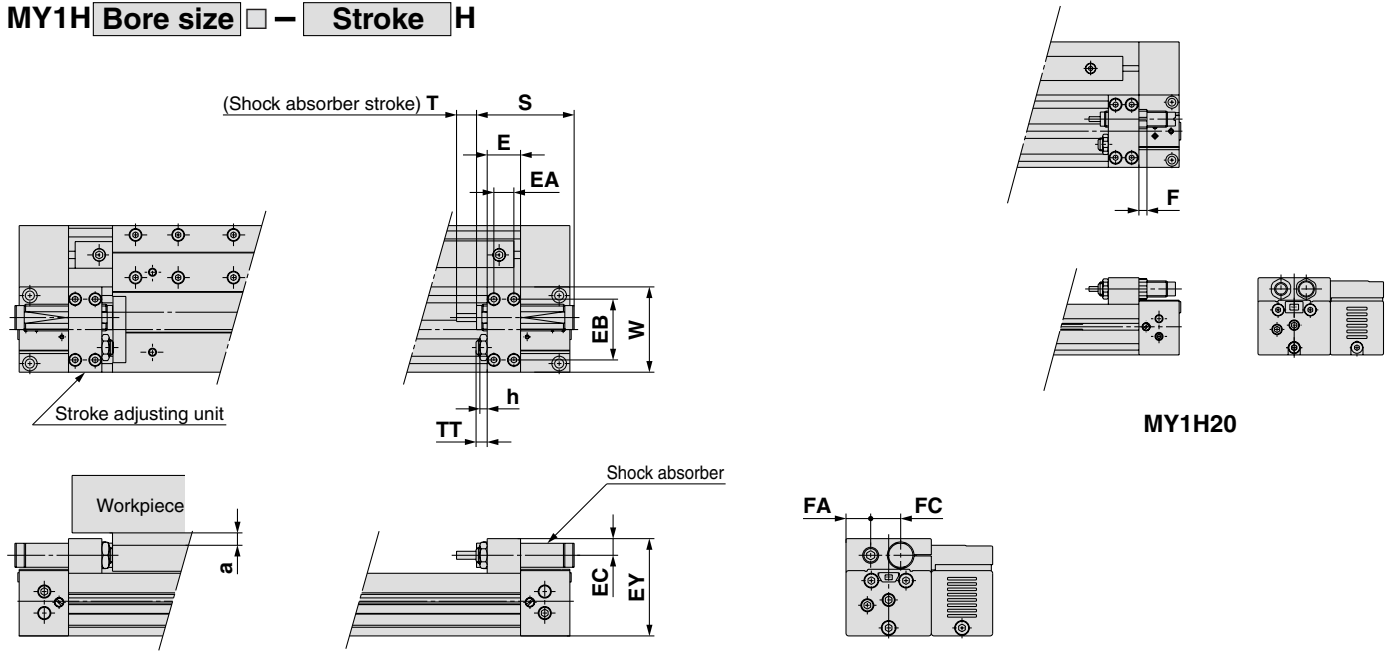

* Since dimension EY of the H type unit is greater than the table top height (dimension H), when mounting a workpiece that exceeds the overall length (dimension L) of the slide table, allow a clearance of dimension "a" or larger on the workpiece side.

Applicable bore size	E	EA	EB	EC	EY	F	FA	FC	h	S	T	TT	W	Shock absorber model	a
MY1H20	19	10	33	7.7	49.5	5	14.3	15.7	3.5	46.7	7	6 (Max. 12)	45	RB1007	4
MY1H25	18	9	40	9	57	—	18	17.5	4.5	67.3	12	5 (Max. 16.5)	53	RB1412	3.5
MY1H32	25	14	45.6	12.4	73	—	18.5	22.5	5.5	73.2	15	8 (Max. 20)	64	RB2015	5.5
MY1H40	31	19	55	12.4	86	—	26.5	22	5.5	73.2	15	9 (Max. 25)	75	RB2015	2.5

- MY1B
- MY1M
- MY1C
- MY1H**
- MY1HT
- MY1□W
- MY2C
- MY2H□
- MY3A
- MY3B
- MY3M

- D-□
- X□
- Individual
- X□
- Technical data

Series MY1H

With End Lock $\phi 16$ to $\phi 40$

(Dimensions for types other than end lock are identical to the standard type dimensions. For details about dimensions, etc., refer to pages 1032 to 1033.)

MY1H□—□E (Right end)

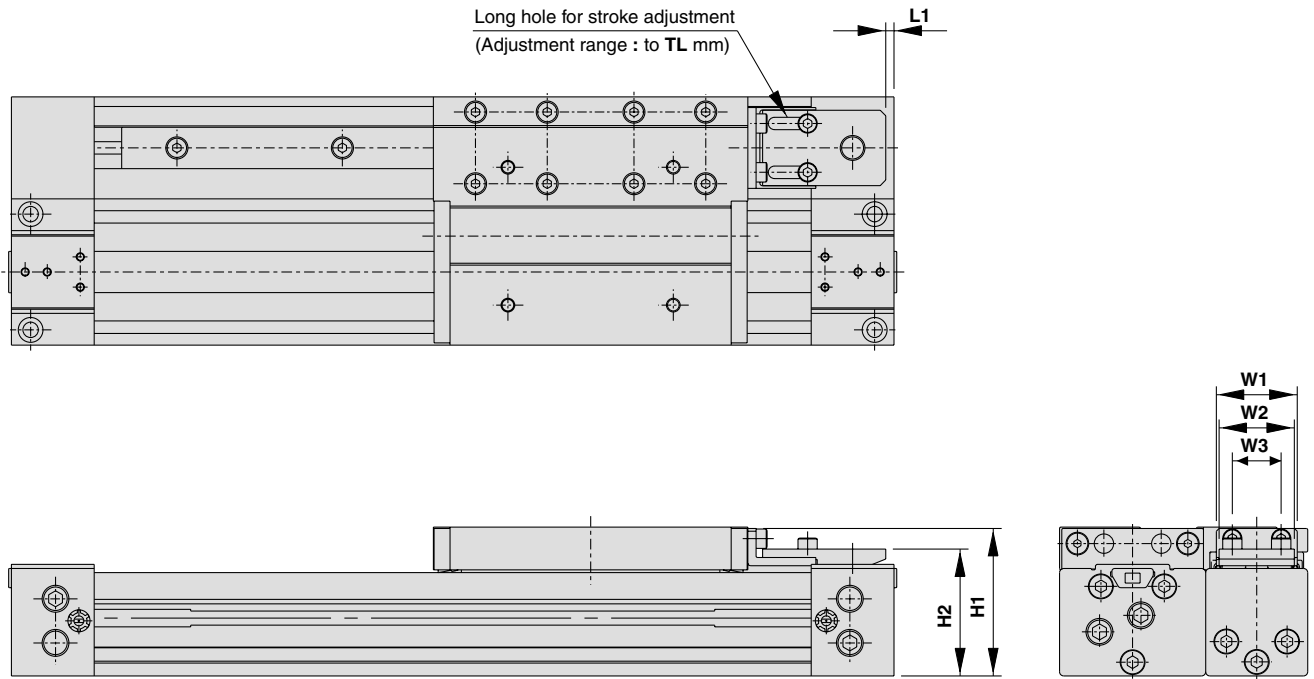

MY1H□—□F (Left end)

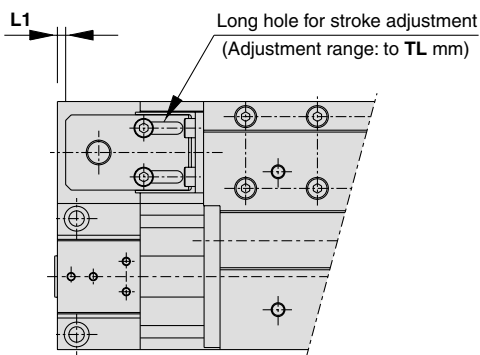

MY1H□—□W (Both ends)

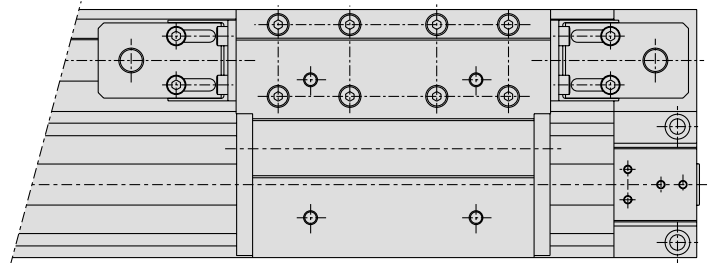

(mm)

Model	H1	H2	L1	TL	W1	W2	W3
MY1H16□	39.2	33	0.5	5.6	18	16	10.4
MY1H20□	45.7	39.5	3	6	18	16	10.4
MY1H25□	53.5	46	3	11.5	29.3	27.3	17.7
MY1H32□	67	56	6.5	12	29.3	27.3	17.7
MY1H40□	83	68.5	10.5	16	38	35	24.4

Side Support

Side support A MY-S□A

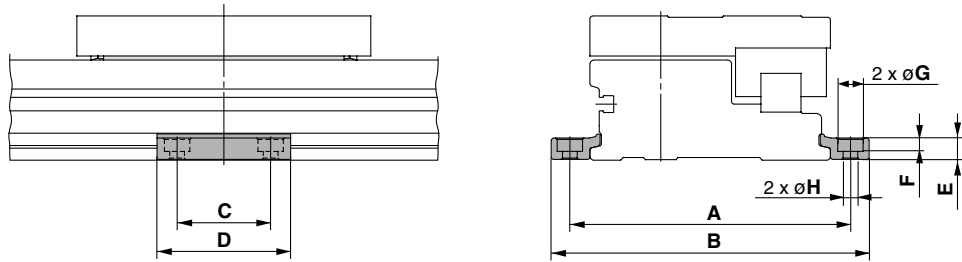

Side support B MY-S□B

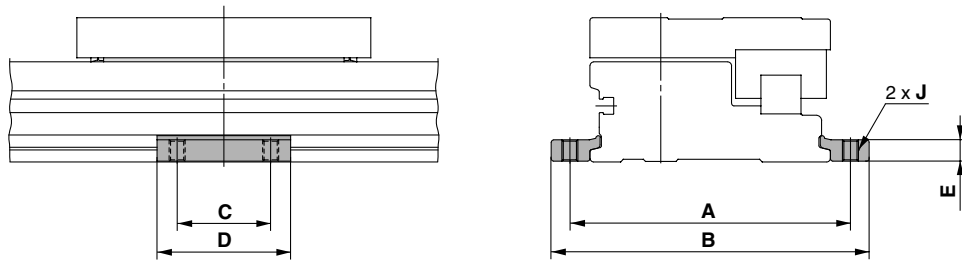

Model	Applicable bore size	A	B	C	D	E	F	G	H	J
MY-S10 ^A _B	MY1H10	53	61.6	12	21	3.6	1.8	6.5	3.4	M4 x 0.7
MY-S16 ^A _B	MY1H16	71	81.6	15	26	4.9	3	6.5	3.4	M4 x 0.7
MY-S20 ^A _B	MY1H20	91	103.6	25	38	6.4	4	8	4.5	M5 x 0.8
MY-S25 ^A _B	MY1H25	105	119	35	50	8	5	9.5	5.5	M6 x 1
MY-S32 ^A _B	MY1H32	130	148	45	64	11.7	6	11	6.6	M8 x 1.25
MY-S40 ^A _B	MY1H40	145	167	55	80	14.8	8.5	14	9	M10 x 1.5

* A set of side supports consists of a left support and a right support.

Guide for Side Support Application

For long stroke operation, the cylinder tube may be deflected depending on its own weight and the load weight. In such a case, use a side support in the middle section. The spacing (ℓ) of the support must be no more than the values shown in the graph on the right.

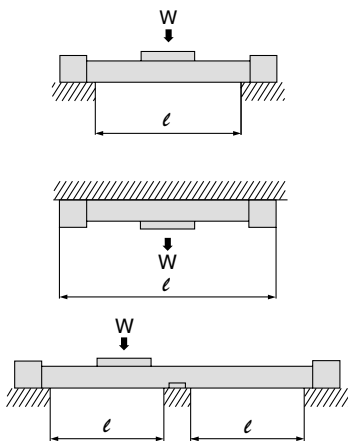

Caution

1. If the cylinder mounting surfaces are not measured accurately, using a side support may cause poor operation. Therefore, be sure to level the cylinder tube when mounting. Also, for long stroke operation involving vibration and impact, use of a side support is recommended even if the spacing value is within the allowable limits shown in the graph.
2. Support brackets are not for mounting; use them solely for providing support.

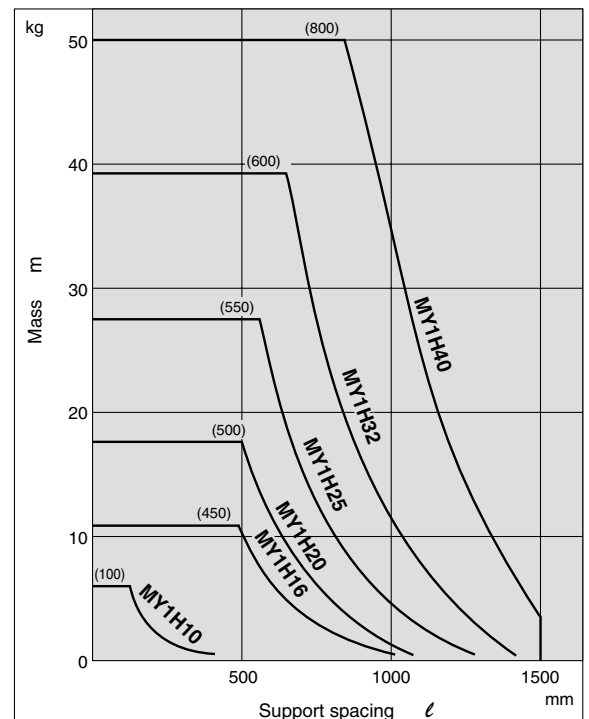

MY1B

MY1M

MY1C

MY1H

MY1HT

MY1□W

MY2C

MY2H□

MY3A

MY3B

MY3M

D-□

-X□

Individual

-X□

Technical

data

Series **MY1HT**

High Rigidity/Linear Guide Type

ø50, ø63

MY1B

MY1M

MY1C

MY1H

MY1HT

MY1□W

MY2C

MY2H□

MY3A
MY3B

MY3M

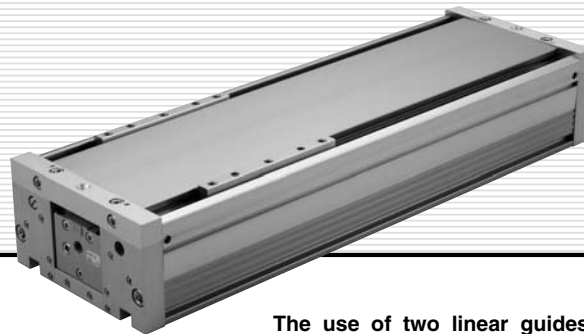

The use of two linear guides allows a maximum load of 320 kg. (ø63)

Rodless cylinder
MY1BH

2 linear guides

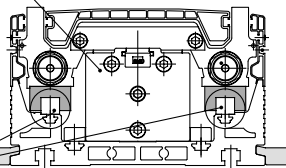

Easy maintenance is stressed by a revolutionary construction which allows cylinder replacement without disturbing the guide units or workpiece.

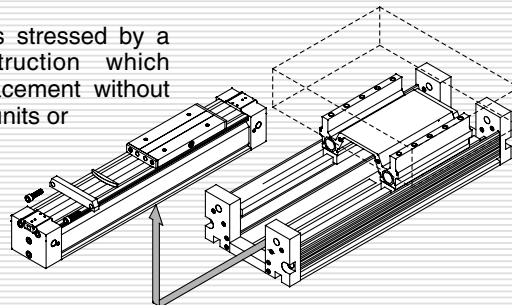

D-□

-X□

Individual
-X□

Technical
data

Series MY1HT Prior to Use

Maximum Allowable Moment/Maximum Load Mass

Model	Bore size (mm)	Maximum allowable moment (N·m)			Maximum load mass (kg)		
		M ₁	M ₂	M ₃	m ₁	m ₂	m ₃
MY1HT	50	140	180	140	200	140	200
	63	240	300	240	320	220	320

The above values are the maximum allowable values for moment and load. Refer to each graph regarding the maximum allowable moment and maximum allowable load for a particular piston speed.

Maximum Allowable Moment

Select the moment from within the range of operating limits shown in the graphs. Note that the maximum allowable load value may sometimes be exceeded even within the operating limits shown in the graphs. Therefore, also check the allowable load for the selected conditions.

Load mass (kg)

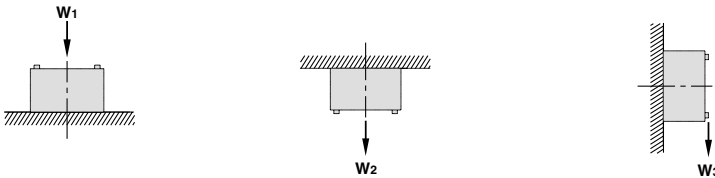

Moment (N·m)

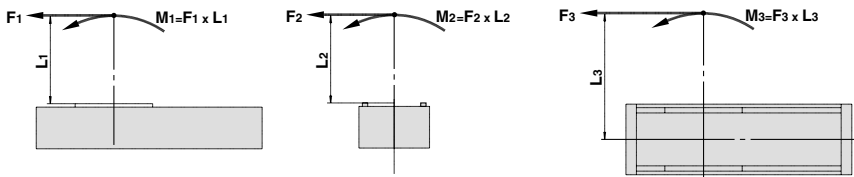

<Calculation of guide load factor>

1. Maximum allowable load (1), static moment (2), and dynamic moment (3) (at the time of impact with stopper) must be examined for the selection calculations.

* To evaluate, use v_a (average speed) for (1) and (2), and v (collision speed $v = 1.4v_a$) for (3). Calculate m_{max} for (1) from the maximum allowable load graph (m_1, m_2, m_3) and M_{max} for (2) and (3) from the maximum allowable moment graph (M_1, M_2, M_3).

$$\text{Sum of guide load factors } \Sigma \alpha = \frac{\text{Load weight [m]}}{\text{Maximum allowable load [m}_{max}]}} + \frac{\text{Static moment [M] }^{(1)}}{\text{Allowable static moment [M}_{max}]}} + \frac{\text{Dynamic moment [M}_E] }^{(2)}}{\text{Allowable dynamic moment [M}_{Emax}]}} \leq 1$$

Note 1) Moment caused by the load, etc., with cylinder in resting condition.

Note 2) Moment caused by the impact load equivalent at the stroke end (at the time of impact with stopper).

Note 3) Depending on the shape of the workpiece, multiple moments may occur. When this happens, the sum of the load factors ($\Sigma \alpha$) is the total of all such moments.

2. Reference formula [Dynamic moment at impact]

Use the following formulae to calculate dynamic moment when taking stopper impact into consideration.

m: Load mass (kg)

F: Load (N)

F_E: Load equivalent to impact (at impact with stopper) (N)

v_a: Average speed (mm/s)

M: Static moment (N·m)

$$v = 1.4v_a \text{ (mm/s)} \quad F_E = 1.4v_a \cdot \delta \cdot m \cdot g \text{ (Note 4)}$$

$$\therefore M_E = \frac{1}{3} \cdot F_E \cdot L_1 = 4.57v_a \delta m L_1 \text{ (Note 5)}$$

v: Collision speed (mm/s)

L₁: Distance to the load's center of gravity (m)

M_E: Dynamic moment (N·m)

δ: Damper coefficient

With rubber bumper = 4/100

(MY1B10, MY1H10)

With air cushion = 1/100

With shock absorber = 1/100

g: Gravitational acceleration (9.8 m/s²)

Note 4) $1.4v_a \delta$ is a dimensionless coefficient for calculating impact force.

Note 5) Average load coefficient ($= \frac{1}{3}$): This coefficient is for averaging the maximum load moment at the time of stopper impact according to service life calculations.

3. For detailed selection procedures, refer to pages 1042 and 1043.

Maximum Load Mass

Select the load from within the range of limits shown in the graphs. Note that the maximum allowable moment value may sometimes be exceeded even within the operating limits shown in the graphs. Therefore, also check the allowable moment for the selected conditions.

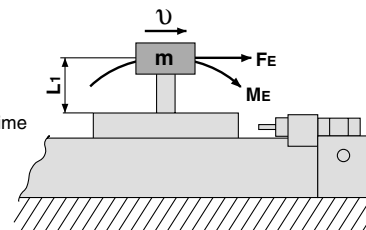

MY1HT/M₁

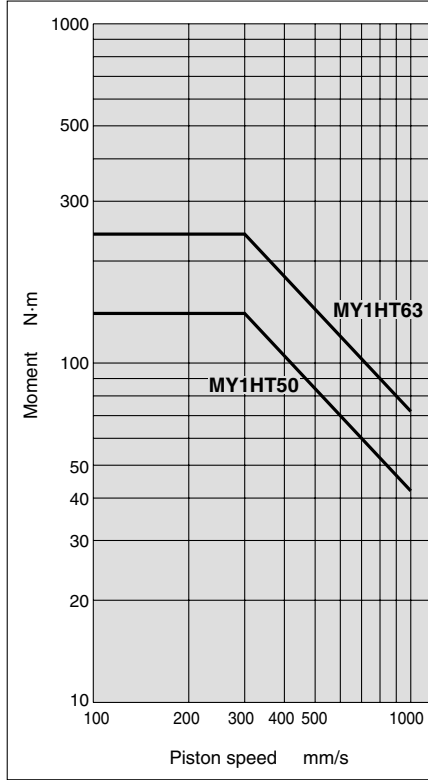

MY1HT/M₂

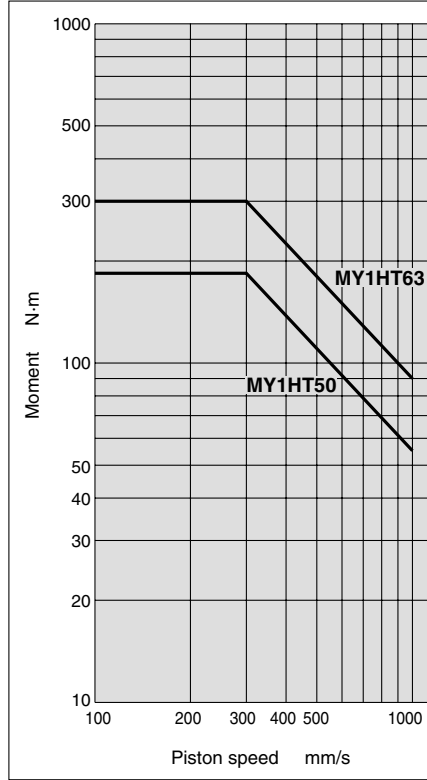

MY1HT/M₃

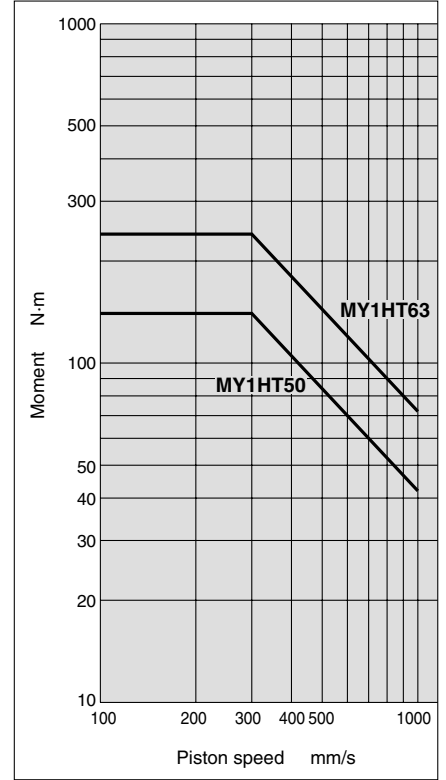

- MY1B
- MY1M
- MY1C
- MY1H
- MY1HT**
- MY1□W
- MY2C
- MY2H□
- MY3A
- MY3B
- MY3M

MY1HT/m₁

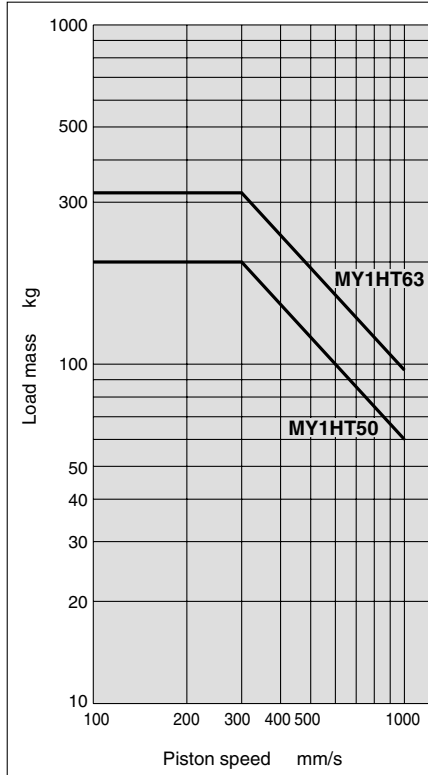

MY1HT/m₂

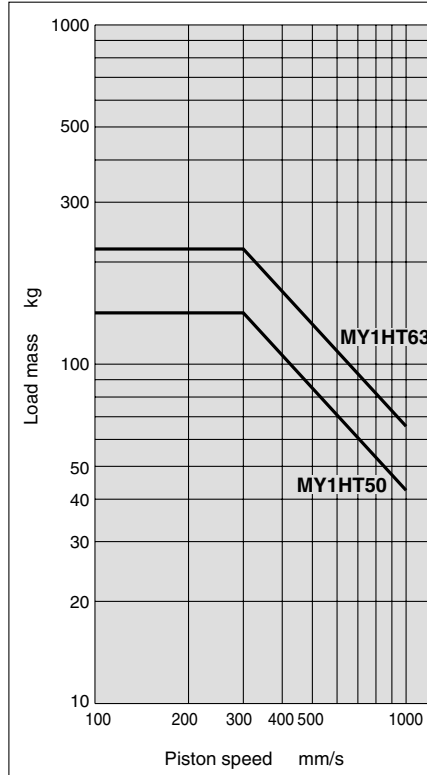

MY1HT/m₃

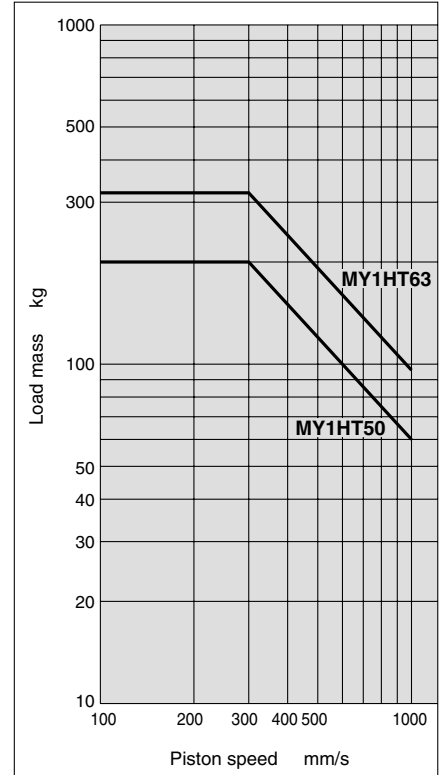

- D-□
- X□
- Individual
- X□
- Technical data

Series MY1HT Model Selection

Following are the steps for selecting the most suitable Series MY1HT to your application.

Calculation of Guide Load Factor

1. Operating Conditions

Cylinder MY1HT50-600
 Average operating speed v_a ... 700 mm/s
 Mounting orientation Vertical mounting
 Cushion Shock absorber
 ($\delta = 1/100$)

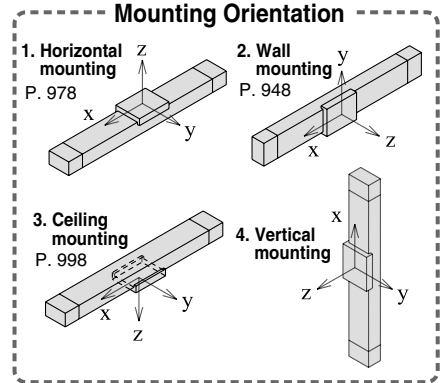
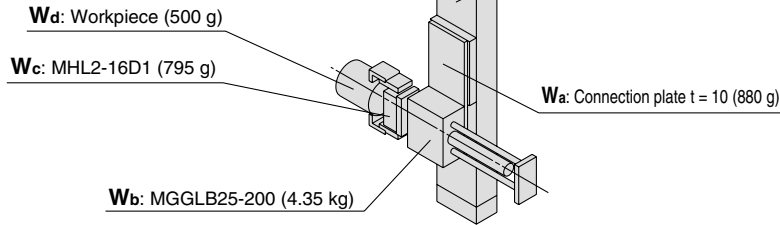

For actual examples of calculation for each orientation, refer to the pages above.

2. Load Blocking

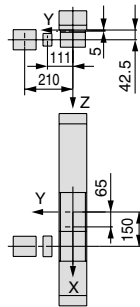

Mass and Center of Gravity for Each Workpiece

Workpiece no. W_n	Mass m_n	Center of gravity		
		X-axis X_n	Y-axis Y_n	Z-axis Z_n
Wa	0.88 kg	65 mm	0 mm	5 mm
Wb	4.35 kg	150 mm	0 mm	42.5 mm
Wc	0.795 kg	150 mm	111 mm	42.5 mm
Wd	0.5 kg	150 mm	210 mm	42.5 mm

n=a, b, c, d

3. Composite Center of Gravity Calculation

$$m_4 = \sum m_n = 0.88 + 4.35 + 0.795 + 0.5 = 6.525 \text{ kg}$$

$$X = \frac{1}{m_4} \times \sum (m_n \times x_n) = \frac{1}{6.525} (0.88 \times 65 + 4.35 \times 150 + 0.795 \times 150 + 0.5 \times 150) = 138.5 \text{ mm}$$

$$Y = \frac{1}{m_4} \times \sum (m_n \times y_n) = \frac{1}{6.525} (0.88 \times 0 + 4.35 \times 0 + 0.795 \times 111 + 0.5 \times 210) = 29.6 \text{ mm}$$

$$Z = \frac{1}{m_4} \times \sum (m_n \times z_n) = \frac{1}{6.525} (0.88 \times 5 + 4.35 \times 42.5 + 0.795 \times 42.5 + 0.5 \times 42.5) = 37.4 \text{ mm}$$

4. Calculation of Load Factor for Static Load

m_4 : Mass

m_4 is the mass which can be transferred by the thrust, and as a rule, is actually about 0.3 to 0.7 of the thrust. (This differs depending on the operating speed.)

M_1 : Moment

$M_1 \text{ max}$ (from (1) of graph MY1HT/ M_1) = 60 (N·m)

$$M_1 = m_4 \times g \times Z = 6.525 \times 9.8 \times 37.4 \times 10^{-3} = 2.39 \text{ (N·m)}$$

$$\text{Load factor } \alpha_1 = M_1 / M_1 \text{ max} = 2.39 / 60 = 0.04$$

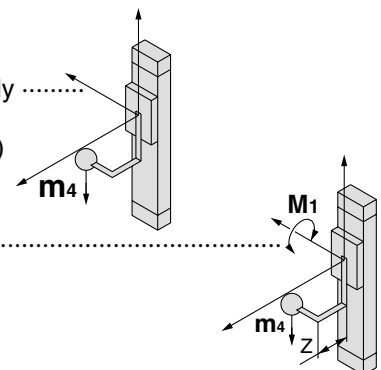

M_3 : Moment

$M_3 \text{ max}$ (from (2) of graph MY1HT/ M_3) = 60 (N·m)

$M_3 = m_4 \times g \times Y = 6.525 \times 9.8 \times 29.6 \times 10^{-3} = 1.89$ (N·m)

Load factor $\alpha_2 = M_3/M_3 \text{ max} = 1.89/60 = 0.03$

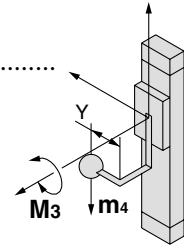

5. Calculation of Load Factor for Dynamic Moment

Equivalent load F_E at impact

$F_E = 1.4Ua \times \delta \times m \times g = 1.4 \times 700 \times \frac{1}{100} \times 6.525 \times 9.8 = 626.7$ (N)

M_{1E} : Moment

$M_{1E} \text{ max}$ (from (3) of graph MY1HT/ M_1 where $1.4Ua = 980$ mm/s) = 42.9 (N·m)

$M_{1E} = \frac{1}{3} \times F_E \times Z = \frac{1}{3} \times 626.7 \times 37.4 \times 10^{-3} = 7.82$ (N·m)

Load factor $\alpha_3 = M_{1E}/M_{1E} \text{ max} = 7.82/42.9 = 0.18$

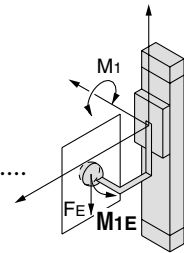

M_{3E} : Moment

$M_{3E} \text{ max}$ (from (4) of graph MY1HT/ M_3 where $1.4Ua = 980$ mm/s) = 42.9 (N·m)

$M_{3E} = \frac{1}{3} \times F_E \times Y = \frac{1}{3} \times 626.7 \times 29.6 \times 10^{-3} = 6.19$ (N·m)

Load factor $\alpha_4 = M_{3E}/M_{3E} \text{ max} = 6.19/42.9 = 0.14$

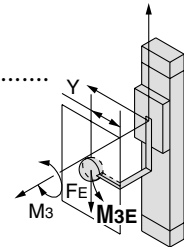

6. Sum and Examination of Guide Load Factors

$\sum \alpha = \alpha_1 + \alpha_2 + \alpha_3 + \alpha_4 = 0.39 \leq 1$

The above calculation is within the allowable value, and therefore the selected model can be used.

Select a shock absorber separately.

In an actual calculation, when the total sum of guide load factors $\sum \alpha$ in the formula above is more than 1, consider either decreasing the speed, increasing the bore size, or changing the product series.

This calculation can be easily made using the "SMC Pneumatics CAD System".

Allowable Moment

MY1HT/ M_1

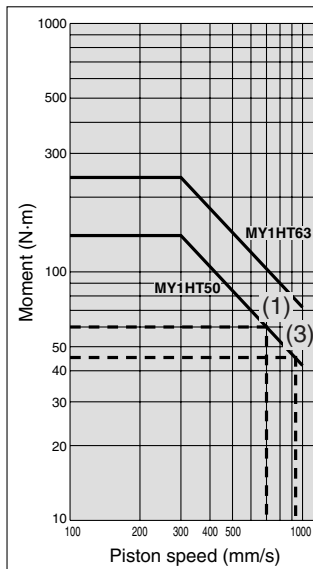

MY1HT/ M_3

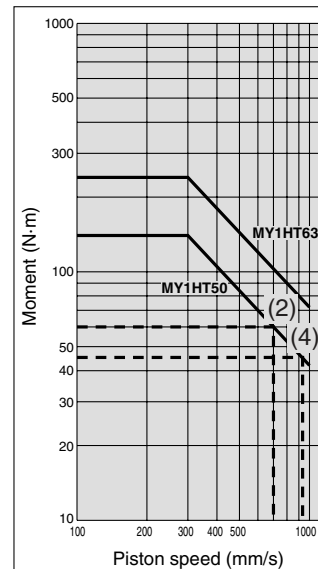

MY1B

MY1M

MY1C

MY1H

MY1HT

MY1W

MY2C

MY2H□

MY3A

MY3B

MY3M

D-□

-X□

Individual

-X□

Technical
data

Mechanically Jointed Rodless Cylinder High Rigidity/Linear Guide Type

Series MY1HT

ø50, ø63

How to Order

High Rigidity/
Linear Guide Type

MY1HT 50 [] [] - 400 L - Y7BW [] - []

High rigidity/Linear guide type
(2 linear guides)

Bore size

50	50 mm
63	63 mm

Port thread type

Symbol	Type	Bore size
Nil	Rc	ø50, ø63
TN	NPT	
TF	G	

Piping

Nil	Standard type
G	Centralized piping type

Made to Order
Refer to page 1045
for details.

Number of
auto switches

Nil	2 pcs.
S	1 pc.
n	"n" pcs.

Auto switch

Nil	Without auto switch (Built-in magnet)
-----	---------------------------------------

* For the applicable auto switch model,
refer to the table below.

Stroke adjusting unit

L	One shock absorber at each stroke end
H	Two shock absorbers at each stroke end
LH	One shock absorber at one end, two shock absorbers at one end

Stroke

Refer to "Standard Stroke"
on page 1045.

Option

Stroke Adjusting Unit Part No.

Bore size (mm)	50	63
Unit type	MYT-A50L	MYT-A63L

Side Support Part No.

Type	Bore size (mm)	
	50	63
Side support A	MY-S63A	
Side support B	MY-S63B	

For details about dimensions, etc., refer to page 1050.
A set of side supports consists of a left support and a right support.

Applicable Auto Switch/Refer to pages 1263 to 1371 for further information on auto switches.

Type	Special function	Electrical entry	Indicator light	Wiring (Output)	Load voltage		Auto switch model		Lead wire length (m)			Pre-wired connector	Applicable load		
					DC	AC	Perpendicular	In-line	0.5 (Nil)	3 (L)	5 (Z)		IC circuit	Relay, PLC	
Solid state switch	Diagnostic indication (2-color indication)	Grommet	Yes	3-wire (NPN)	24V	5V, 12V	—	Y69A	Y59A	●	●	○			○
				3-wire (PNP)				Y7PV	Y7P	●	●	○			
				2-wire	5V, 12V	—	Y69B	Y59B	●	●	○	○			
				3-wire (NPN)			Y7NWV	Y7NW	●	●	○				
				3-wire (PNP)			Y7PWV	Y7PW	●	●	○				
				2-wire			Y7BWV	Y7BW	●	●	○				
Reed switch	—	Grommet	Yes	3-wire (NPN equivalent)	—	5V	—	—	Z76	●	●	—	—	IC circuit	—
				2-wire	24V	12V	100V 100V or less	—	Z73	●	●	●	—	—	Relay, PLC
			No	2-wire	24V	12V	100V 100V or less	—	Z80	●	●	—	—	IC circuit	—

* Lead wire length symbols: 0.5 m.....Nil (Example) Y7BW
3 m.....L (Example) Y7BWL
5 m.....Z (Example) Y7BWZ

* Solid state auto switches marked with "○" are produced upon receipt of order.
* Separate switch spacers (BMP1-032) are required for retrofitting of auto switches.

* There are other applicable auto switches than listed above. For details, refer to page 1053.
* For details about auto switches with pre-wired connector, refer to pages 1328 and 1329.
* Auto switches are shipped together (not assembled).

Mechanically Jointed Rodless Cylinder *Series MY1HT*

High Rigidity/Linear Guide Type

Specifications



JIS Symbol



Bore size (mm)	50	63
Fluid	Air	
Action	Double acting	
Operating pressure range	0.1 to 0.8 MPa	
Proof pressure	1.2 MPa	
Ambient and fluid temperature	5 to 60°C	
Piston speed	100 to 1000 mm/s	
Cushion	Shock absorbers on both ends (Standard)	
Lubrication	Non-lube	
Stroke length tolerance	2700 or less ^{+1.8} ₀ , 2701 to 5000 ^{+2.8} ₀	
Port size	Side port	Rc 3/8

Note) Use at a speed within the absorption capacity range. Refer to page 1046.

Stroke Adjusting Unit Specifications

Applicable bore size (mm)	50		63	
Unit symbol, contents	L	H	L	H
	RB2015 and adjusting bolt: 1 set each	RB2015 and adjusting bolt: 2 sets each	RB2725 and adjusting bolt: 1 set each	RB2725 and adjusting bolt: 2 sets each
Fine stroke adjustment range (mm)	0 to -20		0 to -25	
Stroke adjustment range	For adjustment method, refer to page 1047.			

* Stroke adjustment range is applicable for one side when mounted on a cylinder.

Shock absorber model	RB2015 x 1 pc.	RB2015 x 2 pcs.	RB2725 x 1 pc.	RB2725 x 2 pcs.
Maximum energy absorption (J)	58.8	88.2 ^{Note)}	147	220.5 ^{Note)}
Stroke absorption (mm)	15	15	25	25
Maximum collision speed (mm/s)	1000		1000	
Maximum operating frequency (cycle/min)	25	25	10	10
Spring force (N)	Extended	8.34	16.68	17.66
	Retracted	20.50	41.00	40.02
Operating temperature range (°C)	5 to 60			

Note) Maximum energy absorption for 2 pcs. is calculated by multiplying the value for 1 pc. by 1.5.

* The shock absorber service life is different from that of the MY1HT cylinder depending on operating conditions. Refer to the RB Series Specific Product Precautions for the replacement period.

Theoretical Output

Bore size (mm)	Piston area (mm ²)	Operating pressure (MPa)						
		0.2	0.3	0.4	0.5	0.6	0.7	0.8
50	1962	392	588	784	981	1177	1373	1569
63	3115	623	934	1246	1557	1869	2180	2492

Note) Theoretical output (N) = Pressure (MPa) x Piston area (mm²)

Standard Stroke

Bore size (mm)	Standard stroke (mm) ^{Note)}	Maximum manufacturable stroke (mm)
50-63	200, 400, 600, 800, 1000, 1500, 2000	5000

Note) Cylinders other than the standard stroke type are manufactured upon request for special order.

Mass

Bore size (mm)	Basic mass	Additional mass per each 25 mm of stroke	Side support mass (per set)	Stroke adjusting unit mass		
			Type A and B	L unit mass	LH unit mass	H unit mass
50	30.62	0.87	0.17	0.62	0.93	1.24
63	41.69	1.13	0.17	1.08	1.62	2.16

Calculation: (Example) **MY1HT50-400L**

- Basic mass30.62 kg
- Additional mass0.87/25 st
- L unit mass0.62 kg

- Cylinder stroke..... 400 st
- 30.62 + 0.87 x 400 ÷ 25 + 0.62 x 2 ≒ 45.8



Made to Order Specifications

(For details, refer to pages 1395 to 1498 and 1553.)

Symbol	Specifications
—XC67	NBR rubber lining in dust seal band

MY1B

MY1M

MY1C

MY1H

MY1HT

MY1□W

MY2C

MY2H□

MY3A

MY3B

MY3M

D-□

-X□

Individual -X□

Technical data

Series MY1HT

Cushion Capacity

Cushion Selection

<Stroke adjusting unit with built-in shock absorber>

L unit

Use this unit when the cylinder stroke is outside of the effective air cushion range even if the load and speed are within the air cushion limit line, or when the cylinder is operated in a load and speed range above the air cushion limit line or below the L unit limit line.

H unit

Use this unit when the cylinder is operated in a load and speed range above the L unit limit line and below the H unit limit line.

Stroke Adjusting Unit Absorption Capacity

MY1HT50 Horizontal collision: P = 0.5 MPa

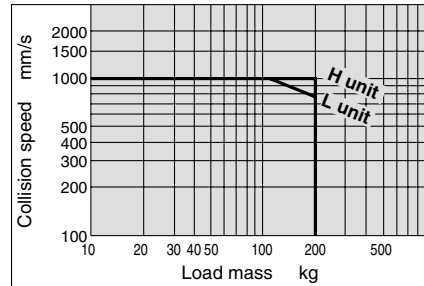

MY1HT63 Horizontal collision: P = 0.5 MPa

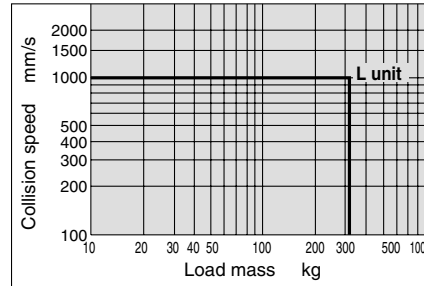

Stopper Bolt Holding Screw Tightening Torque

Stopper Bolt

Tightening Torque for Stroke Adjusting Unit Lock Plate Holding Bolts (N·m)

Bore size (mm)	Tightening torque
50	0.6
63	1.5

Calculation of Absorbed Energy for Stroke Adjusting Unit with Built-in Shock Absorber (N·m)

Type of impact	Horizontal collision	Vertical (Downward)	Vertical (Upward)
Kinetic energy E_1			
Thrust energy E_2	F·s	F·s + m·g·s	F·s - m·g·s
Absorbed energy E	$E_1 + E_2$		

Symbol

v: Speed of impact object (m/s)

F: Cylinder thrust (N)

s: Shock absorber stroke (m)

m: Mass of impact object (kg)

g: Gravitational acceleration (9.8 m/s²)

Note) The speed of the impact object is measured at the time of impact with the shock absorber.

⚠ Precautions

Be sure to read before handling. Refer to front matters 54 and 55 for Safety Instructions and pages 3 to 11 for Actuator and Auto Switch Precautions.

Mounting

⚠ Caution

- Do not put hands or fingers inside when the body is suspended.

Since the body is heavy, use eye bolts when suspending it. (The eye bolts are not included with the body.)

Stroke Adjustment Method

⚠ Caution

- As shown in Figure (1), to adjust the stopper bolt within the adjustment range A, insert a hexagon wrench from the top to loosen the hexagon socket head set screw by approximately one turn, and then adjust the stopper bolt with a flat head screwdriver.
- When the adjustment described in 1 above is insufficient, the shock absorber can be adjusted. Remove the covers as shown in Figure (2) and make further adjustment by loosening the hexagon nut.
- Various dimensions are indicated in Table (1). Never make an adjustment that exceeds the dimensions in the table, as it may cause an accident and/or damage.

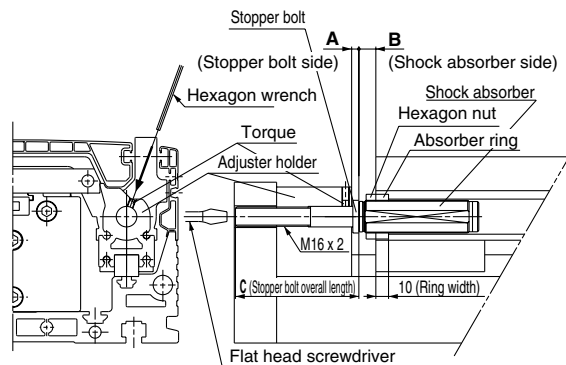

Figure (1) Stroke adjusting section detail

Bore size (mm)	50	63
A to A Max.	6 to 26	6 to 31
B to B Max.	14 to 54	14 to 74
C	87	102
Max. adjustment range	60	85

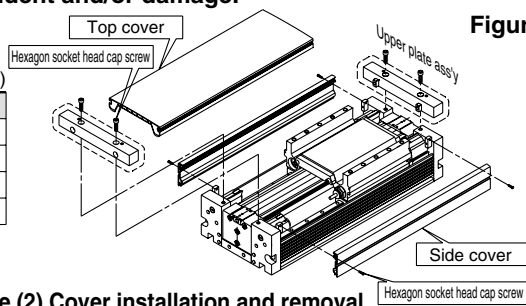

Figure (2) Cover installation and removal

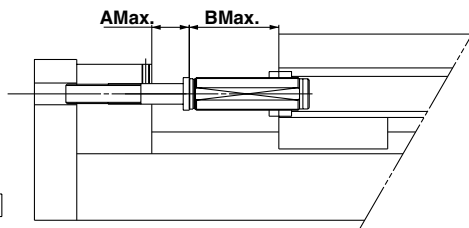

Figure (3) Maximum stroke adjustment detail

Disassembly and Assembly Procedure

⚠ Caution

Disassembly step

- Remove the hexagon socket head cap screws 1, and remove the upper plates.
- Remove the top cover.
- Remove the hexagon socket head cap screws 2, and remove the end covers and couplers.
- Remove the hexagon socket head cap screws 3.
- Remove the hexagon socket head cap screws 4, and remove the end supports.
- Remove the cylinder.

Assembly step

- Insert the MY1BH cylinder.
- Temporarily fasten the end supports with the hexagon socket head cap screws 4.
- With two hexagon socket head cap screws 3 on the L or R side, pull the end support and the cylinder.
- Tighten the hexagon socket head cap screws 3 on the other side to eliminate the looseness in the axial direction. (At this point, a space is created between the end support and the end plate on one side, but this is not a problem.)
- Re-tighten the hexagon socket head cap screws 4.
- Fasten the end cover with the hexagon head cap screws 2, while making sure that the coupler is in the right direction.
- Place the top cover on the body.
- Insert the holding blocks into the top cover and fasten the upper plates with the hexagon socket head cap screws 1.

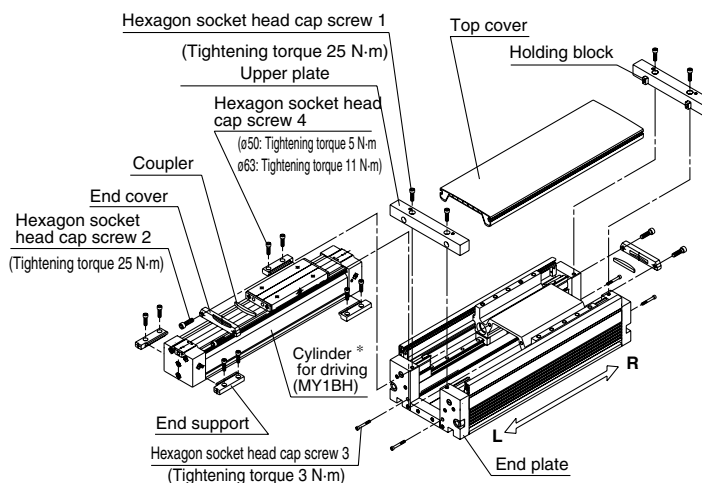

* Cylinder For Driving (Series MY1BH)

Since Series MY1BH is a cylinder for driving for Series MY1HT, its construction is different from Series MY1B. Do not use Series MY1B as a cylinder for driving, since it will lead to damage.

How to Order

High rigidity/Linear guide type **MY1HT** **50** **300** **L** **Z73**

Cylinder for driving **MY1BH** **50** **300**

Bore size •

50	50 mm
63	63 mm

Port thread type •

Symbol	Type	Bore size
Nil	Rc	ø50, ø63
TN	NPT	
TF	G	

Piping •

Nil	Standard type
G	Centralized piping type

- MY1B
- MY1M
- MY1C
- MY1H
- MY1HT
- MY1□W
- MY2C
- MY2H□
- MY3A
- MY3B
- MY3M

- D-□
- X□
- Individual -X□
- Technical data

Series MY1HT

Construction

Standard type

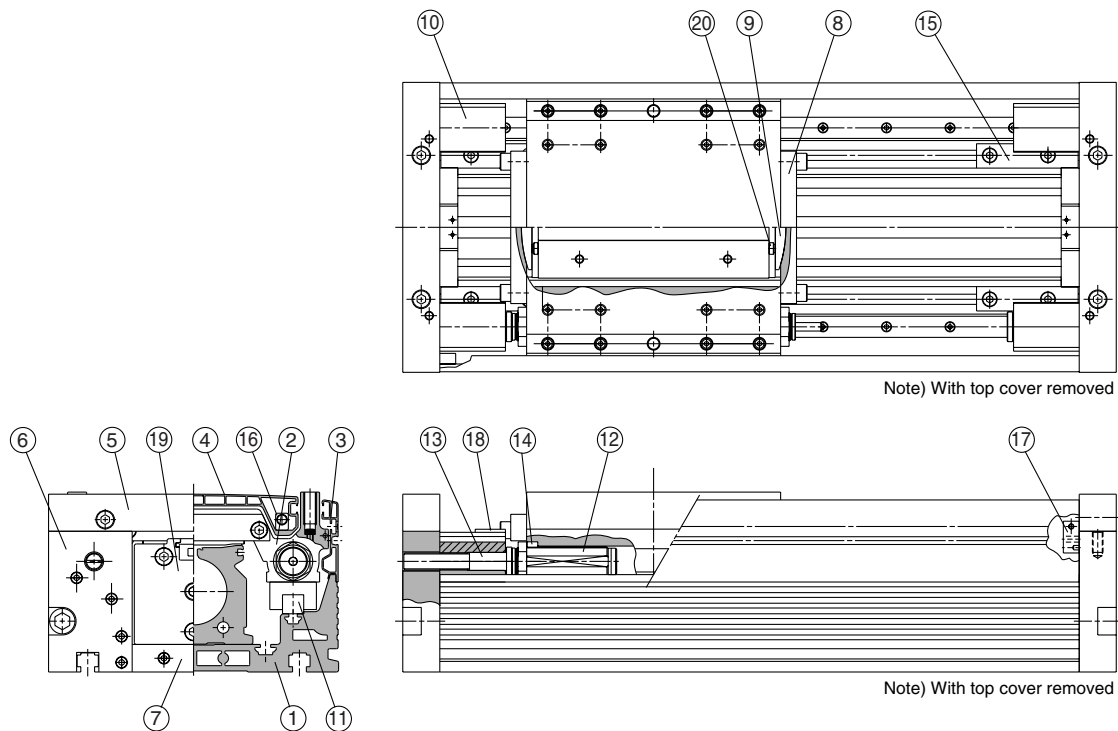

Component Parts

No.	Description	Material	Note
1	Guide frame	Aluminum alloy	Hard anodized
2	Slide table	Aluminum alloy	Hard anodized
3	Side cover	Aluminum alloy	Hard anodized
4	Top cover	Aluminum alloy	Hard anodized
5	Upper plate	Aluminum alloy	Hard anodized
6	End plate	Aluminum alloy	Hard anodized
7	Bottom plate	Aluminum alloy	Hard anodized
8	End cover	Aluminum alloy	Chromated
9	Coupler	Aluminum alloy	Chromated
10	Adjuster holder	Aluminum alloy	Hard anodized
11	Guide	—	
12	Shock absorber	—	
13	Stopper bolt	Carbon steel	Nickel plated
14	Absorber ring	Rolled steel	Nickel plated
15	End support	Aluminum alloy	Hard anodized
16	Top block	Aluminum alloy	Chromated
17	Side block	Aluminum alloy	Chromated
18	Slide plate	Special resin	
19	Rodless cylinder	—	MY1BH
20	Stopper	Carbon steel	Nickel plated

Mechanically Jointed Rodless Cylinder High Rigidity/Linear Guide Type **Series MY1HT**

Standard Type/Centralized Piping Type $\phi 50, \phi 63$

Refer to page 1056 regarding centralized piping port variations.

MY1HT50□/63□ — **Stroke**

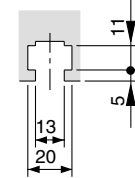
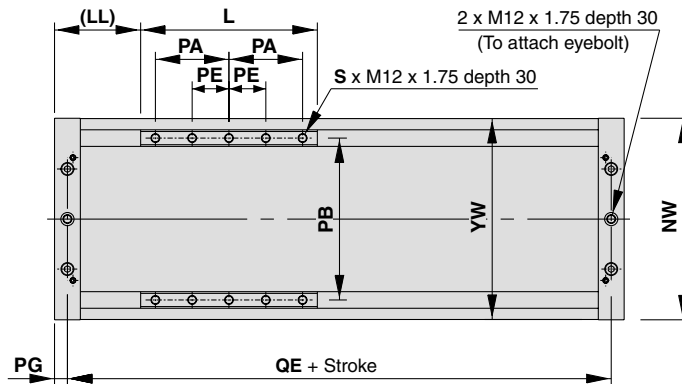

Applicable nut JIS B 1163
Square nut M12

Dimensions of T-slot for mounting

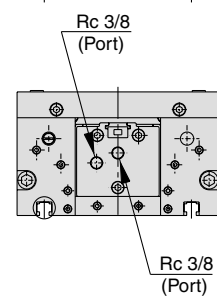
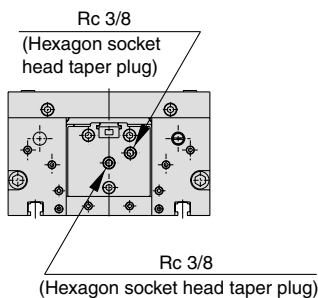
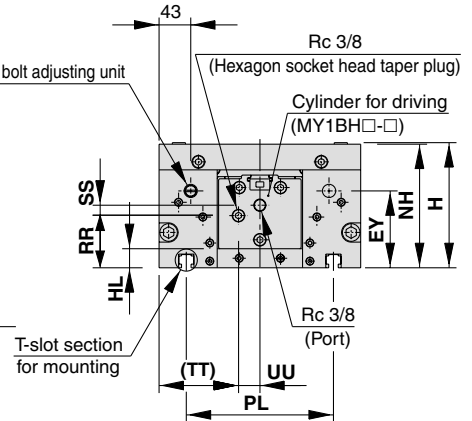
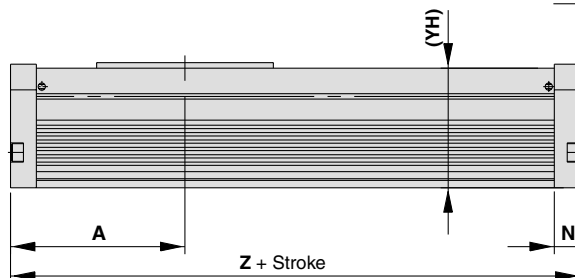
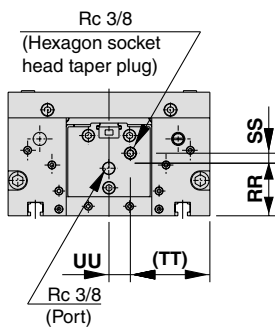

MY1HT□G

MY1HT□G

(mm)

Model	A	EY	H	HL	L	LL	N	NH	NW	PA	PB	PE	PG
MY1HT50□	207	97.5	145	23	210	102	30	143	254	90	200	-	15
MY1HT63□	237	104.5	170	26	240	117	35	168	274	100	220	50	17.5

(mm)

Model	PL	QE	RR	S	SS	TT	UU	YH	YW	Z
MY1HT50□	180	384	57	6	10	103.5	23.5	136.4	253	414
MY1HT63□	200	439	71.5	10	13.5	108	29	162.6	273	474

MY1B

MY1M

MY1C

MY1H

MY1HT

MY1□W

MY2C

MY2H□

MY3A

MY3B

MY3M

D-□

-X□

Individual

-X□

Technical

data

Series MY1HT

Side Support

Side support A MY-S63A

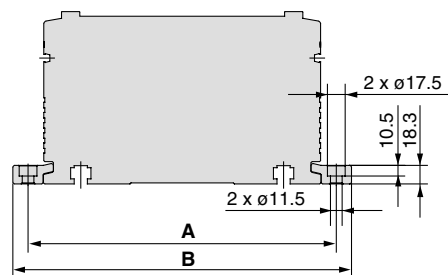
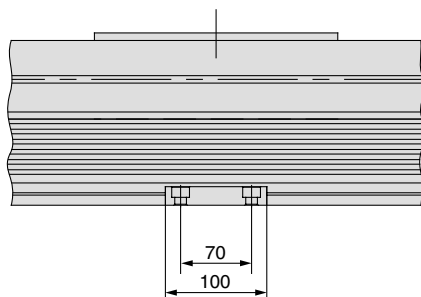

Side support B MY-S63B

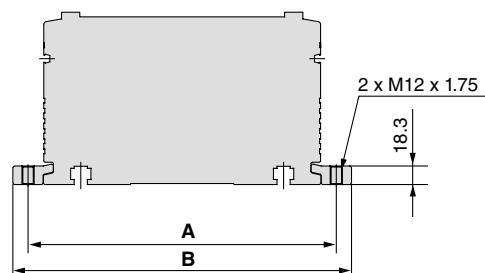
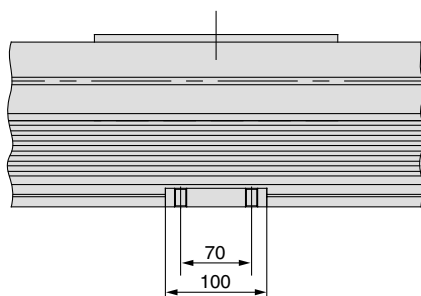

Dimensions (mm)

Model	Applicable bore size	A	B
MY-S63 _A	MY1HT50	284	314
	MY1HT63	304	334

* A set of side supports consists of a left support and a right support.

Guide for Side Support Application

For long stroke operation, the cylinder tube may be deflected depending on its own weight and the load weight. In such a case, use a side support in the middle section. The spacing (ℓ) of the support must be no more than the values shown in the graph on the right.

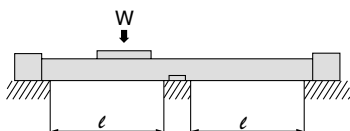
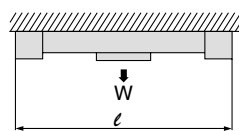
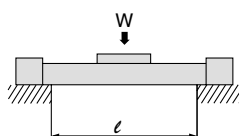

⚠ Caution

1. If the cylinder mounting surfaces are not measured accurately, using a side support may cause poor operation. Therefore, be sure to level the cylinder tube when mounting. Also, for long stroke operation involving vibration and impact, use of a side support is recommended even if the spacing value is within the allowable limits shown in the graph.
2. Support brackets are not for mounting; use them solely for providing support.

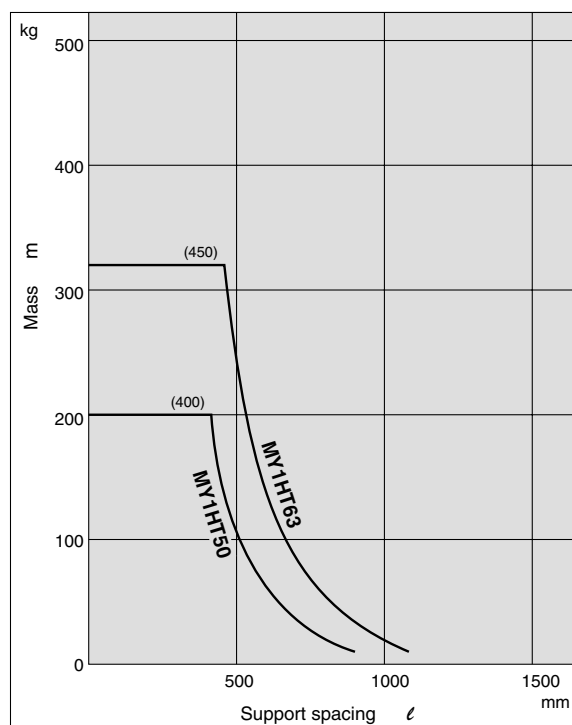

Proper Auto Switch Mounting Position (Detection at stroke end)

MY1B (Basic type)

ø10, ø16, ø20

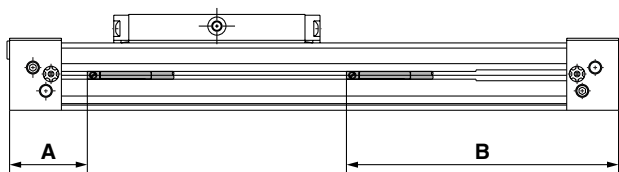

ø25 to ø100

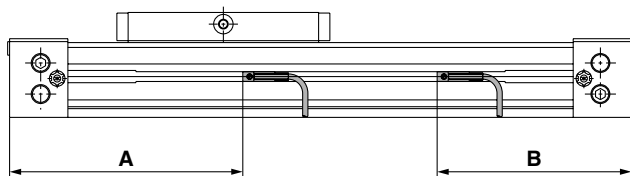

Proper Auto Switch Mounting Position (mm)

Auto switch model	D-M9□ D-M9□V D-M9□W D-M9□WV		D-A9□ D-A9□V		D-Y59□/Y7P D-Y69□/Y7PV D-Y7□W D-Y7□WV D-Z7□/Z80	
	A	B	A	B	A	B
Bore size						
10	24	86	20	90	—	—
16	31.5	128.5	27.5	132.5	—	—
20	39	161	35	165	—	—
25	136.5	83.5	—	—	131.5	88.5
32	185	95	—	—	180	100
40	—	—	—	—	216	124
50	277.5	122.5	—	—	272.5	127.5
63	322.5	137.5	—	—	317.5	142.5
80	489.5	200.5	—	—	484.5	205.5
100	574.5	225.5	—	—	569.5	230.5

Note 1) D-M9□□□type cannot be mounted on ø40.

Note 2) Adjust the auto switch after confirming the operating condition in the actual setting.

MY1M (Slide bearing guide type)

ø16, ø20

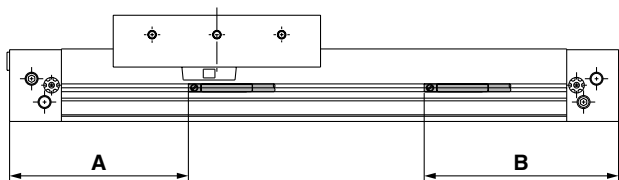

ø25 to ø63

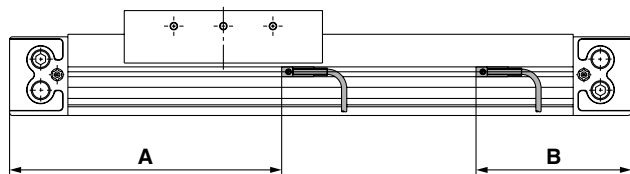

Proper Auto Switch Mounting Position (mm)

Auto switch model	D-M9□ D-M9□V D-M9□W D-M9□WV		D-A9□ D-A9□V		D-Y59□/Y7P D-Y69□/Y7PV D-Y7□W D-Y7□WV D-Z7□/Z80	
	A	B	A	B	A	B
Bore size						
16	74	86	70	90	—	—
20	94	106	90	110	—	—
25	—	—	—	—	139.5	80.5
32	189.5	90.5	—	—	184.5	95.5
40	—	—	—	—	229.5	110.5
50	283.5	116.5	—	—	278.5	121.5
63	328.5	131.5	—	—	323.5	136.5

Note 1) D-M9□□□type cannot be mounted on ø25 and ø40.

Note 2) Adjust the auto switch after confirming the operating condition in the actual setting.

MY1C (Cam follower guide type)

ø16, ø20

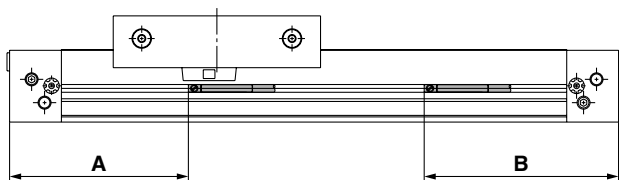

ø25 to ø63

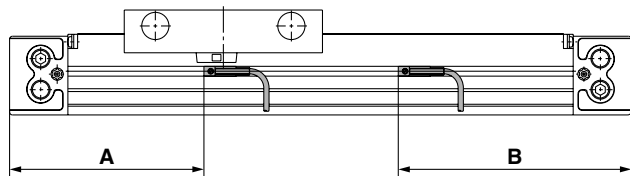

Proper Auto Switch Mounting Position (mm)

Auto switch model	D-M9□ D-M9□V D-M9□W D-M9□WV		D-A9□ D-A9□V		D-Y59□/Y7P D-Y69□/Y7PV D-Y7□W D-Y7□WV D-Z7□/Z80	
	A	B	A	B	A	B
Bore size						
16	74	86	70	90	—	—
20	94	106	90	110	—	—
25	102	118	—	—	97	123
32	132	148	—	—	127	153
40	—	—	—	—	157.5	182.5
50	283.5	116.5	—	—	278.5	121.5
63	328.5	131.5	—	—	323.5	136.5

Note 1) D-M9□□□type cannot be mounted on ø40.

Note 2) Adjust the auto switch after confirming the operating condition in the actual setting.

MY1B

MY1M

MY1C

MY1H

MY1HT

MY1□W

MY2C

MY2H□

MY3A
MY3B

MY3M

D-□

-X□

Individual
-X□

Technical
data

Series MY1

Proper Auto Switch Mounting Position (Detection at stroke end)

MY1H (Linear guide type)

ø10, ø16, ø20

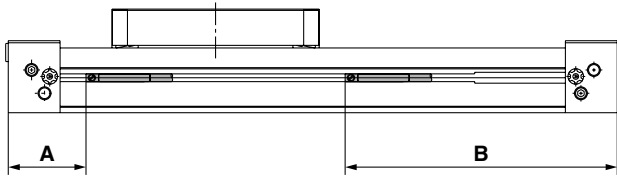

ø25 to ø40

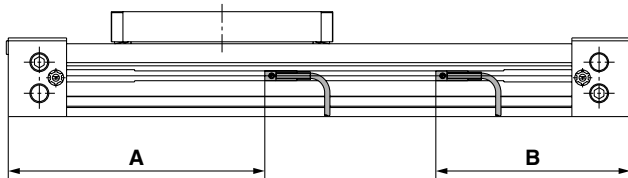

Proper Auto Switch Mounting Position (mm)

Auto switch model	D-M9□ D-M9□V D-M9□W D-M9□WV		D-A9□ D-A9□V		D-Y59□/Y7P D-Y69□/Y7PV D-Y7□W D-Y7□WV D-Z7□/Z80	
	A	B	A	B	A	B
Bore size						
10	24	86	20	90	—	—
16	31.5	128.5	27.5	132.5	—	—
20	39	161	35	165	—	—
25	136.5	83.5	132.5	87.5	131.5	88.5
32	185	94	181	99	180	100
40	231	119	217	123	216	124

Note) Adjust the auto switch after confirming the operating condition in the actual setting.

MY1HT (High rigidity/Linear guide type)

ø50, ø63

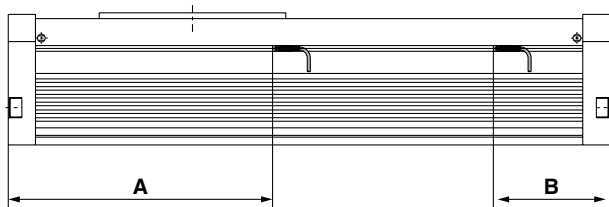

Proper Auto Switch Mounting Position (mm)

Auto switch model	D-Y59□/Y7P D-Y69□/Y7PV D-Y7□W D-Y7□WV D-Z7□/Z80	
	A	B
Bore size		
50	290.5	333.5
63	123.5	138.5

Note) Adjust the auto switch after confirming the operating condition in the actual setting.

Mechanically Jointed Rodless Cylinder *Series MY1*

Operating Range

Note) Since this is a guideline including hysteresis, not meant to be guaranteed. (Assuming approximately ±30% dispersion.)
There may be the case it will vary substantially depending on an ambient environment.

MY1B (Basic type) (mm)

Auto switch model	Bore size									
	10	16	20	25	32	40	50	63	80	100
D-A9□/A9□V	6	6.5	8.5	—	—	—	—	—	—	—
D-M9□/M9□V D-M9□W/M9□WV	3.5	4	5.5	5.5	7	—	11.5	12	12	11.5
D-Z7□/Z80	—	—	—	8.5	11.5	11.5	11.5	11.5	11.5	11.5
D-Y59□/Y69I D-Y7P/Y7PV D-Y7□W/Y7□WV	—	—	—	6	9	10	3.5	3.5	3.5	3.5

D-M9□□type cannot be mounted on ø40.

MY1M (Slide bearing guide type) (mm)

Auto switch model	Bore size						
	16	20	25	32	40	50	63
D-A9□/A9□V	11	7.5	—	—	—	—	—
D-M9□/M9□V D-M9□W/M9□WV	7.5	7.5	—	8.5	—	7	6
D-Z7□/Z80	—	—	12	12	12	11.5	11.5
D-Y59□/Y69I D-Y7P/Y7PV D-Y7□W/Y7□WV	—	—	5	5	5	5.5	5.5

D-M9□□type cannot be mounted on ø25 and ø40.

MY1C (Cam follower guide type) (mm)

Auto switch model	Bore size						
	16	20	25	32	40	50	63
D-A9□/A9□V	11	7.5	—	—	—	—	—
D-M9□/M9□V D-M9□W/M9□WV	7.5	7.5	7	8	—	7	6
D-Z7□/Z80	—	—	12	12	12	11.5	11.5
D-Y59□/Y69I D-Y7P/Y7PV D-Y7□W/Y7□WV	—	—	5	5	5	5.5	5.5

D-M9□□type cannot be mounted on ø40.

MY1H (Linear guide type) (mm)

Auto switch model	Bore size					
	10	16	20	25	32	40
D-A9□/A9□V	11	6.5	8.5	—	—	—
D-M9□/M9□V D-M9□W/M9□WV	3	4.5	5	5.5	6	6.5
D-Z7□/Z80	—	—	—	8.5	11.5	11.5
D-Y59□/Y69I D-Y7P/Y7PV D-Y7□W/Y7□WV	—	—	—	6	9	10

MY1HT (High rigidity/Linear guide type) (mm)

Auto switch model	Bore size	
	50	63
D-Z7□/Z80	11	11
D-Y59□/Y69I D-Y7P/Y7PV D-Y7□W/Y7□WV	5	5

MY1B

MY1M

MY1C

MY1H

MY1HT

MY1□W

MY2C

MY2H□

MY3A

MY3B

MY3M

Switch Mounting Bracket: Part No.

Auto switch model	Bore size (mm)	
	ø10, ø16, ø20	ø25 to ø63
D-A9□/A9□V D-M9□/M9□V D-M9□W/M9□WV	—	BMG2-012

Note1) D-A9□□type cannot be mounted on ø25 to ø100 of Series MY1. D-M9□□ type cannot be mounted on ø25 and ø40 of Series MY1M, and ø40 of Series MY1B and MY1C.

ø25 to ø63: M9□(V)/M9□W(V)

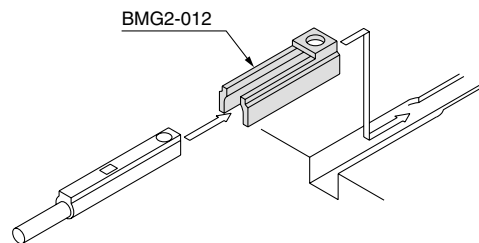

Besides the models listed in How to Order, the following auto switches are applicable.
Refer to pages 1263 to 1371 for the detailed specifications.

Auto switch type	Part no.	Electrical entry (Fetching direction)	Features	Applicable bore size
Solid state	D-Y69A, Y69B, Y7PV	Grommet (Perpendicular)	—	ø25 to ø100
	D-Y7NWV, Y7PWV, Y7BWV		Diagnostic indication (2-color indication)	
	D-Y59A, Y59B, Y7P	Grommet (In-line)	—	
	D-Y7NW, Y7PW, Y7BW		Diagnostic indication (2-color indication)	

* For solid state auto switches, auto switches with a pre-wired connector are also available. Refer to pages 1328 and 1329 for details.

* Normally closed (NC = b contact) solid state auto switches (D-F9G/F9H/Y7G/Y7H types) are also available. Refer to pages 1290 and 1292 for details.

D-□

-X□

Individual

-X□

Technical data



Series MY1

Specific Product Precautions 1

Be sure to read before handling.

Refer to front matters 54 and 55 for Safety Instructions and pages 3 to 11 for Actuator and Auto Switch Precautions.

Selection

⚠ Caution

1. When using a cylinder with long strokes, implement an intermediate support.

When using a cylinder with long strokes, implement an intermediate support to prevent the tube from sagging and being deflected by vibration or an external load.

Refer to the Guide for Side Support Application on pages 971, 993, 1013, 1037 and 1050.

2. For intermediate stops, use a dual-side pressure control circuit.

Since the mechanically jointed rodless cylinders have a unique seal structure, slight external leakage may occur. Controlling intermediate stops with a 3 position valve cannot hold the stopping position of the slide table (slider). The speed at the restarting state also may not be controllable. Use the dual-side pressure control circuit with a PAB-connected 3 position valve for intermediate stops.

3. Constant speed.

Since the mechanically jointed rodless cylinders have a unique seal structure, a slight speed change may occur. For applications that require constant speed, select an applicable equipment for the level of demand.

4. Load factor of 0.5 or less

When the load factor is high against the cylinder output, it may adversely affect the cylinder (condensation, etc.) and cause malfunctions. Select a cylinder to make the load factor less than 0.5. (Mainly when using an external guide)

5. Cautions on less frequent operation

When the cylinder is used extremely infrequently, operation may be interrupted in order for anchoring and a change lubrication to be performed or service life may be reduced.

6. Consider uncalculated loads such as piping, cableveyor, etc., when selecting a load moment

Calculation does not include the external acting force of piping, cableveyor, etc. Select load factors taking into account the external acting force of piping, cableveyor, etc.

7. Accuracy

The mechanical jointed rodless cylinder does not guarantee traveling parallelism. When accuracy in traveling parallelism and a middle position of stroke is required, please consult SMC.

Mounting

⚠ Caution

1. Do not apply strong impacts or excessive moment to the slide table (slider).

- The slide table (slider) is supported by precision bearings (MY1C, MY1H) or resin bearings. Therefore, do not apply strong impacts or excessive moment, etc., when mounting workpieces.

Mounting

⚠ Caution

2. When connecting to a load which has an external guide mechanism, use a discrepancy absorption mechanism.

- Mechanically jointed rodless cylinders can be used with a direct load within the allowable range for each type of guide. Please note that careful alignment is necessary when connecting to a load having an external guide mechanism. Mount the external guide mounting brackets and floating brackets in a place where the required degree of freedom for the floating Y and Z axes can be secured.

The thrust transmission area of the floating bracket must be fixed so that it does not partially contact the body.

- * Refer to the Coordinates and Moment in Model Selection on page 947 for the details of floating Y and Z axes.

3. Do not mount cylinders as they are twisted.

When mounting, be sure for a cylinder tube not to be twisted. The flatness of the mounting surface is not appropriate, the cylinder tube is twisted, which may cause air leakage due to the detachment of a seal belt, damage a dust seal band, and cause malfunctions.

4. Do not mount a slide table on the fixed equipment surface.

It may cause damage or malfunctions since an excessive load is applied to the bearing.

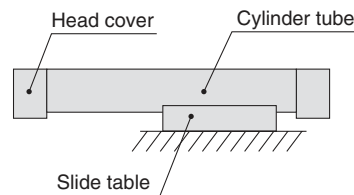

Mounting with a slide table (slider)

5. Consult SMC when mounting in a cantilevered way.

Since the cylinder body deflects, it may cause malfunctions. Please consult SMC when using it this way.

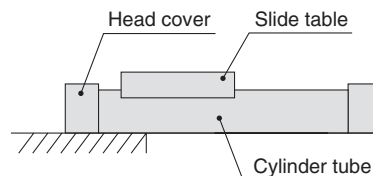

Mounting in a cantilevered way

6. Fixed parts of the cylinder on both ends must have at least 5 mm of contact between where the bottom of the cylinder tube and the equipment surface.

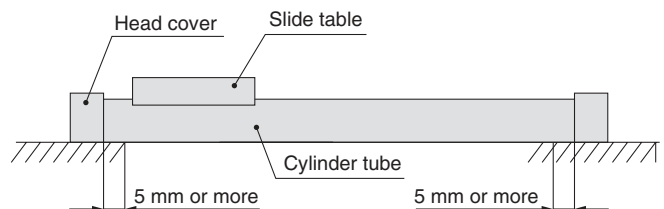



Series MY1

Specific Product Precautions 2

Be sure to read before handling.

Refer to front matters 54 and 55 for Safety Instructions and pages 3 to 11 for Actuator and Auto Switch Precautions.

Mounting

⚠ Caution

7. Do not generate negative pressure in the cylinder tube.

Take precautions under operating conditions in which negative pressure is generated inside the cylinder by external forces or inertial forces. Air leakage may occur due to separation of the seal belt. Do not generate negative pressure in the cylinder by forcibly moving it with an external force during the trial operation or dropping it with self-weight under the non-pressure state, etc. When the negative pressure is generated, slowly move the cylinder by hand and move the stroke back and forth. After doing so, if air leakage still occurs, please consult SMC.

Handling

⚠ Caution

1. Do not unnecessarily alter the guide adjustment setting.

• The adjustment of the guide is preset and does not require readjustment under normal operating conditions. Therefore, do not unnecessarily alter the guide adjustment setting. However, series other than the MY1H Series can be readjusted and their bearings can be replaced.

To perform these operations, refer to the bearing replacement procedure given in the instruction manual.

2. Do not get your hands caught during cylinder operation.

For the cylinder with a stroke adjusting unit, the space between the slide table and stroke adjusting unit is very small, and your hands may get caught. When operating without a protective cover, be careful not to get your hands caught.

3. Avoid operation that causes negative pressure inside the cylinder.

Take precautions under operating conditions in which negative pressure is increased inside the cylinder by external forces or inertial forces. Air leakage may occur due to separation of the seal belt.

Operating Environment

⚠ Warning

1. Do not use in an environment where the cylinder is exposed to coolant, cutting oil, water drops, adhesive foreign particles, dust, etc. and avoid use with compressed air containing drainage and foreign particles.

• Foreign matter or liquids on the cylinder's interior or exterior can wash out the lubricating grease, which can lead to deterioration and damage of dust seal band and seal materials, causing a danger of malfunction.

When operating in locations with exposure to water and oil, or in dusty locations, provide protection such as a cover to prevent direct contact with the cylinder, or mount so that the dust seal band surface faces downward, and operate with clean compressed air.

2. Carry out cleaning and grease application suitable for the operating environment.

Carry out cleaning regularly when using in an operating environment in which the product is likely to get dirty.

After cleaning, be sure to apply grease to the top side of the cylinder tube and the rotating part of the dust seal band. Apply grease to these parts regularly even if not after cleaning. Please consult SMC for the cleaning of the slide table (slider) interior and grease application.

Service Life and Replacement Period of Shock Absorber

⚠ Caution

1. Allowable operating cycle under the specifications set in this catalog is shown below.

1.2 million times RB08□□

2 million times RB10□□ to RB2725

Note) Specified service life (suitable replacement period) is the value at room temperature (20 to 25°C). The period may vary depending on the temperature and other conditions. In some cases the absorber may need to be replaced before the allowable operating cycle above.

MY1B

MY1M

MY1C

MY1H

MY1HT

MY1□W

MY2C

MY2H□

MY3A

MY3B

MY3M

D-□

-X□

Individual
-X□

Technical
data



Series MY1 Specific Product Precautions 3

Be sure to read before handling.

Refer to front matters 54 and 55 for Safety Instructions and pages 3 to 11 for Actuator and Auto Switch Precautions.

⚠ Caution

Centralized Piping Port Variations

- Head cover piping connection can be freely selected to best suit different piping conditions.

Applicable bore size	Port variations
<p>MY1B10 MY1H10</p>	<p>Note 1) These ports are not applicable to MY1H10.</p>
<p>MY1B16 to 100 MY1M16 to 63 MY1C16 to 63 MY1H16 to 40</p> <p>O-ring Piping tube</p>	<p>Note 2)</p> <p>Note 2)</p>
<p>MY1HT50/63</p>	

Mechanically Jointed Rodless Cylinder with Protective Cover

Series MY1□W

ø16, ø20, ø25, ø32, ø40, ø50, ø63

Protective cover offers excellent dust and water resistance

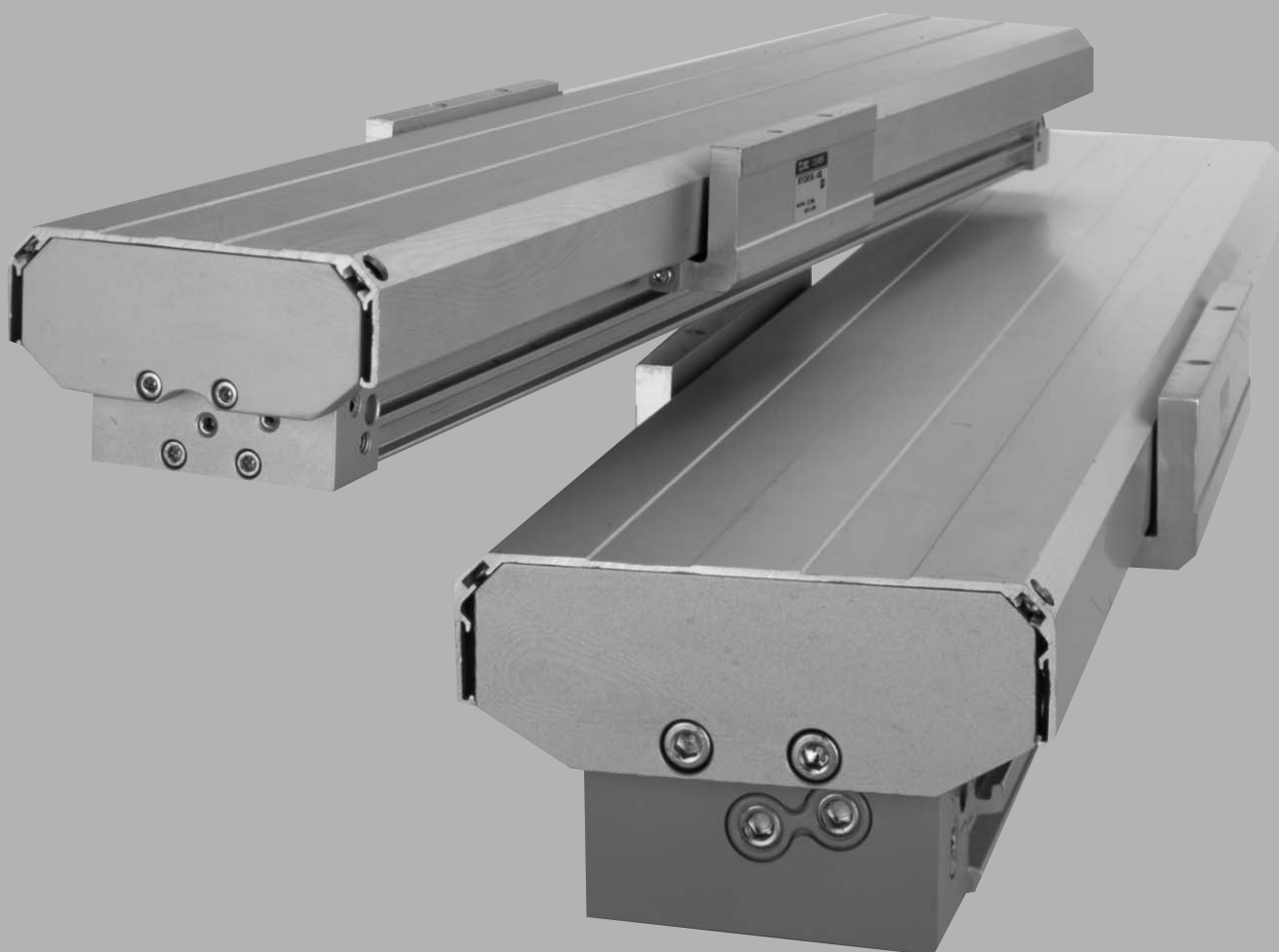

- MY1B
- MY1M
- MY1C
- MY1H
- MY1HT
- MY1□W**
- MY2C
- MY2H□
- MY3A
- MY3B
- MY3M

Series	Guide type	Cover	Bore size (mm)							Option
			16	20	25	32	40	50	63	
MY1MW	Slide bearing guide	With protective cover	●	●	●	●	●	●	●	<ul style="list-style-type: none"> • Centralized piping • Stroke adjusting unit • Side support
MY1MWK		With protective cover With side seal	●	●	●	●	●			
MY1CW	Cam follower guide	With protective cover	●	●	●	●	●	●		
MY1CWK		With protective cover With side seal	●	●	●	●	●			

- D-□
- X□
- Individual -X□
- Technical data

Series MY1□W

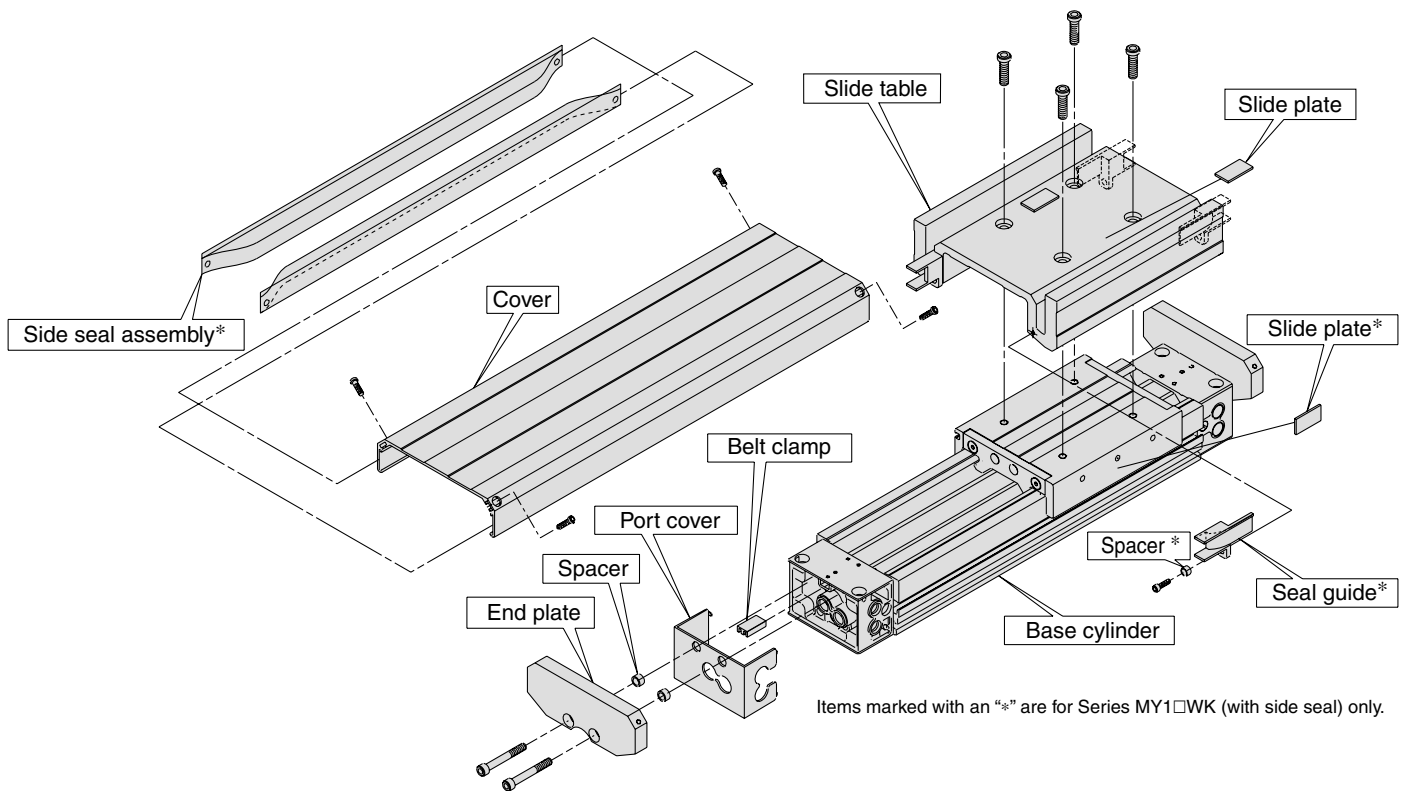

1 Dustproof and water resistant features are improved for using in locations where the cylinder is exposed to powder dust and water drop or splash.

2 Side seals provide greater lateral dustproof and water resistance.

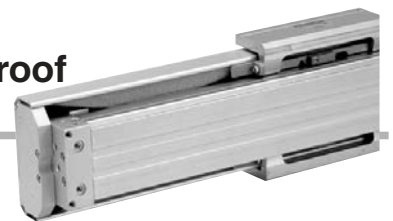

3 The cover in no way interferes with the installation of base cylinder option.

4 Cover units and side seal units can be installed on the already existing Series MY1M/MY1C.

5 Protective cover only minimally adds to overall length.

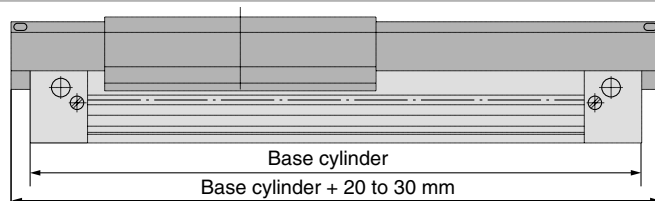

6 Water-resistant solid state switches can be mounted.

Model Selection 1

This section illustrates the standard model selection procedure to help you choose the most suitable cylinders from Series MY1MW/MY1CW for your application needs.

Standards for Tentative Model Selection

Cylinder model	Guide type	Standards for guide selection	Graphs for related allowable values
MY1MW	Slide bearing guide type	Slide table ⁽²⁾ accuracy approx. ±0.12 mm	P.1062
MY1CW	Cam follower guide type	Slide table ⁽²⁾ accuracy approx. ±0.05 mm	P.1063

Note 1) These accuracy values for each guide should be used only as a guide during selection. Please contact SMC when guaranteed accuracy for MY1CW is required.

Note 2) "Accuracy" here means displacement of the slide table (at stroke end) when 50% of the allowable moment shown in the catalog is applied. (reference value).

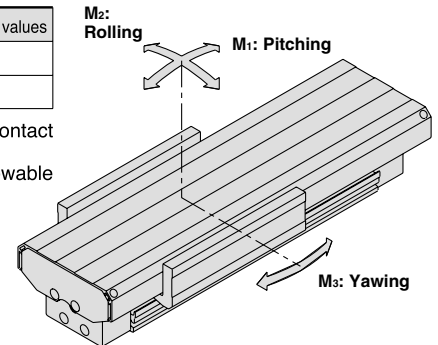

- MY1B
- MY1M
- MY1C
- MY1H
- MY1HT
- MY1□W
- MY2C
- MY2H□
- MY3A
- MY3B
- MY3M

Selection Flow Chart

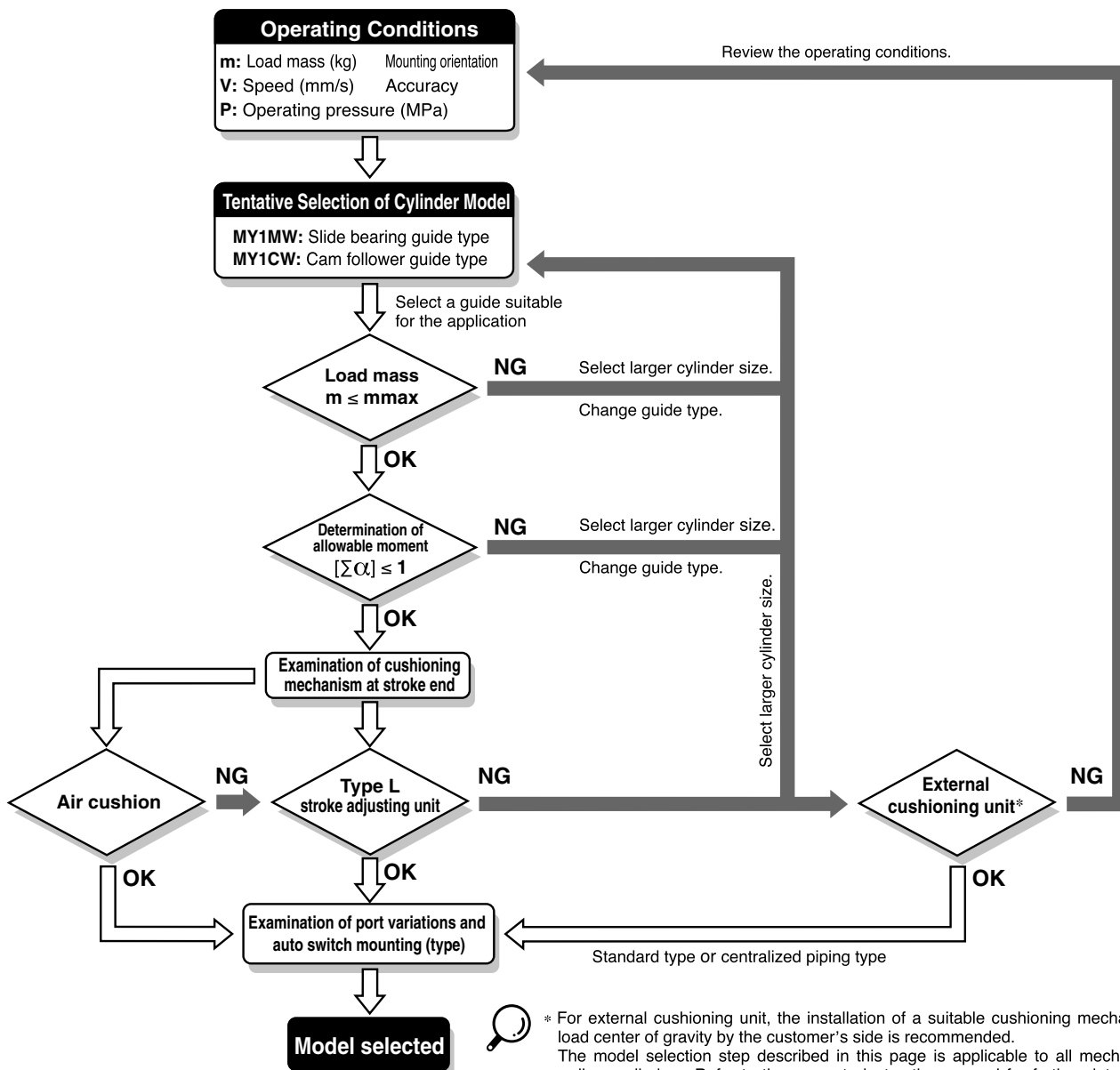

* For external cushioning unit, the installation of a suitable cushioning mechanism near the load center of gravity by the customer's side is recommended. The model selection step described in this page is applicable to all mechanically jointed rodless cylinders. Refer to the separate instruction manual for further details. If you have any questions, please contact SMC.

- D-□
- X□
- Individual -X□
- Technical data

Types of Moment Applied to Rodless Cylinders

Multiple moments may be generated depending on the mounting orientation, load, and position of the center of gravity.

Coordinates and Moments

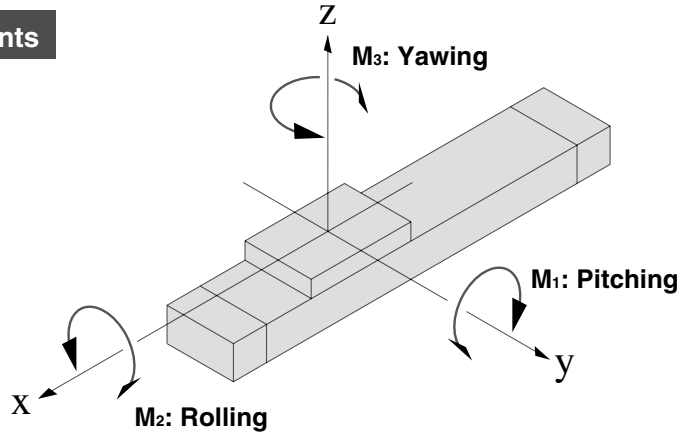

Static Moment

Horizontal mounting

Ceiling mounting

Wall mounting

Vertical mounting

g: Gravitational acceleration

Mounting orientation	Horizontal mounting	Ceiling mounting	Wall mounting	Vertical mounting
Static load (m)	m_1	m_2	m_3	m_4 (Note)
Static moment				
M_1	$m_1 \times g \times X$	$m_2 \times g \times X$	—	$m_4 \times g \times Z$
M_2	$m_1 \times g \times Y$	$m_2 \times g \times Y$	$m_3 \times g \times Z$	—
M_3	—	—	$m_3 \times g \times X$	$m_4 \times g \times Y$

Note) "m₄" is a mass movable by thrust. Use 0.3 to 0.7 times the thrust (varies depending on the operating speed) as a guide for actual use.

Dynamic Moment

Mounting orientation	Horizontal mounting	Ceiling mounting	Wall mounting	Vertical mounting
Dynamic load F_E	$\frac{1.4}{100} \times U_a \times m_n \times g$			
Dynamic moment				
M_{1E}	$\frac{1}{3} \times F_E \times Z$			
M_{2E}	Dynamic moment M_{2E} is not generated.			
M_{3E}	$\frac{1}{3} \times F_E \times Y$			

g: Gravitational acceleration, U_a : Average speed

Note) Regardless of the mounting orientation, dynamic moment is calculated using the formulas above.

Maximum Allowable Moment/Maximum Load Mass

Maximum Allowable Moment

Select the moment from within the range of operating limits shown in the graphs. Note that the maximum allowable load value may sometimes be exceeded even within the operating limits shown in the graphs. Therefore, also check the allowable load for the selected conditions.

Model	Bore size (mm)	Maximum allowable moment (N·m)			Maximum load mass (kg)		
		M ₁	M ₂	M ₃	m ₁	m ₂	m ₃
MY1MW	16	6.0	3.0	1.0	18	7	2.1
	20	10	5.2	1.7	26	10.4	3
	25	15	9.0	2.4	38	15	4.5
	32	30	15	5.0	57	23	6.6
	40	59	24	8.0	84	33	10
	50	115	38	15	120	48	14
MY1CW	16	6.0	3.0	2.0	18	7	2.1
	20	10	5.0	3.0	25	10	3
	25	15	8.5	5.0	35	14	4.2
	32	30	14	10	49	21	6
	40	60	23	20	68	30	8.2
	50	115	35	35	93	42	11.5
63	150	50	50	130	60	16	

The above values are the maximum allowable values for moment and load. Refer to each graph regarding the maximum allowable moment and maximum allowable load for a particular piston speed.

Load mass (kg)

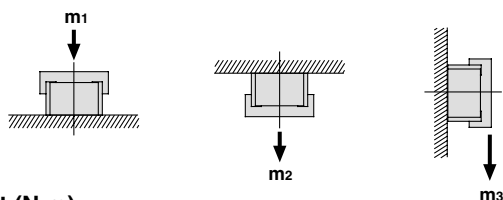

Caution

- The cylinder should be mounted in m1 orientation if maximum dustproofing is required.

Moment (N·m)

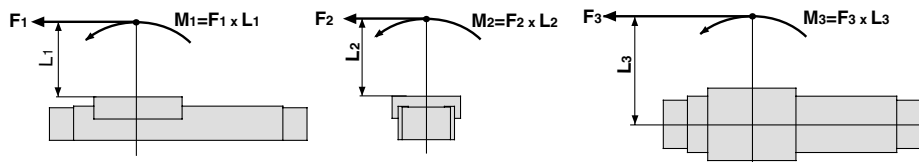

Maximum Load Mass

Select the load from within the range of limits shown in the graphs. Note that the maximum allowable moment value may sometimes be exceeded even within the operating limits shown in the graphs. Therefore, also check the allowable moment for the selected conditions.

<Calculation of guide load factor>

- Three factors must be considered when computing calculations for selection: (1) Maximum load mass, (2) Static moment, (3) Dynamic moment (at the time of impact with stopper).
 * To evaluate, use \bar{v}_a (average speed) for (1) and (2), and v (collision speed $v = 1.4 \bar{v}_a$) for (3). Calculate m_{max} for (1) from the maximum allowable load graph ($m_1, m_2,$ and m_3), and M_{max} for (2) and (3) from the maximum allowable moment graph ($M_1, M_2,$ and M_3).

$$\text{Sum of guide load factors } \sum \alpha = \frac{\text{Load mass [m]}}{\text{Maximum allowable load [m}_{max}\text{]}} + \frac{\text{Static moment [M]} \text{ (Note 1)}}{\text{Allowable static moment [M}_{max}\text{]}} + \frac{\text{Dynamic moment [M}_E\text{]} \text{ (Note 2)}}{\text{Allowable dynamic moment [M}_{Emax}\text{]}} \leq 1$$

Note 1) Moment caused by the load, etc., with cylinder in resting condition.

Note 2) Moment caused by the impact load equivalent at the stroke end (at the time of impact with stopper).

Note 3) Depending on the shape of the workpiece, multiple moments may occur. When this happens, the sum of the load factors ($\sum \alpha$) is the total of all such moments.

2. Reference formula [Dynamic moment at impact]

Use the following formulae to calculate dynamic moment when taking stopper impact into consideration.

- m: Load mass (kg)
- F: Load (N)
- F_E: Load equivalent to impact (at impact with stopper) (N)
- \bar{v}_a : Average speed (mm/s)
- M: Static moment (N·m)
- v: Collision speed (mm/s)
- L₁: Distance to the load's center of gravity (m)
- M_E: Dynamic moment (N·m)
- g: Gravitational acceleration (9.8 m/s²)

$$v = 1.4 \bar{v}_a \text{ (mm/s)} \quad F_E = \frac{1.4}{100} \bar{v}_a \cdot g \cdot m \text{ (Note 4)}$$

$$\therefore M_E = \frac{1}{3} F_E \cdot L_1 = 0.05 \bar{v}_a m L_1 \text{ (N·m) (Note 5)}$$

Note 4) $\frac{1.4}{100} \bar{v}_a$ is a dimensionless coefficient for calculating impact force.

Note 5) Average load coefficient (= $\frac{1}{3}$): This coefficient is for averaging the maximum load moment at the time of stopper impact according to service life calculations.

- For detailed selection procedures, refer to pages 1066 and 1067.

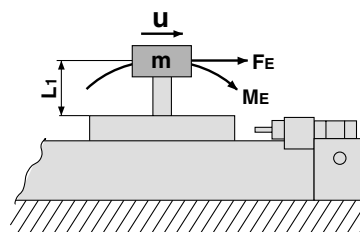

- MY1B
- MY1M
- MY1C
- MY1H
- MY1HT
- MY1□W
- MY2C
- MY2H□
- MY3A
- MY3B
- MY3M

- D-□
- X□
- Individual -X□
- Technical data

Series MY1□W

Maximum Allowable Moment/Maximum Load Mass

Maximum Allowable Moment: MY1MW

MY1MW/M₁

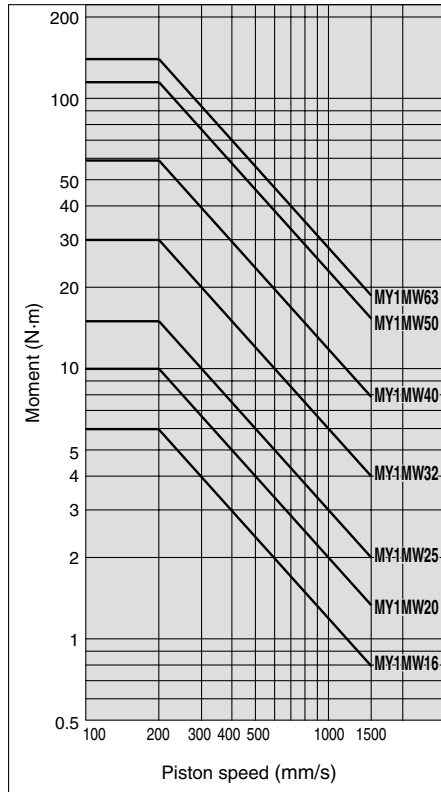

MY1MW/M₂

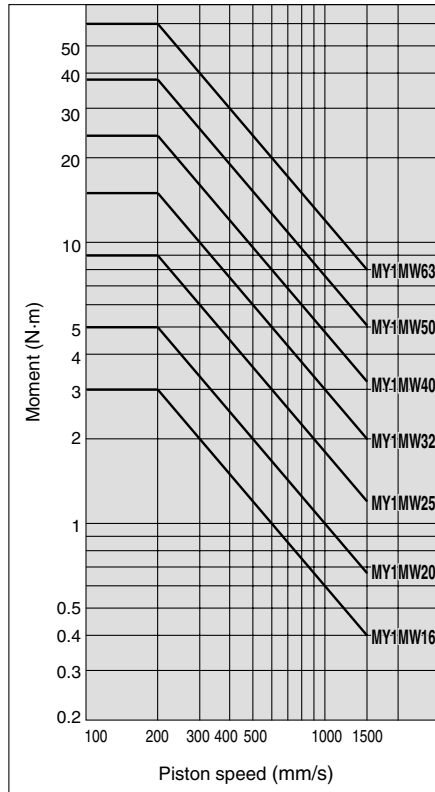

MY1MW/M₃

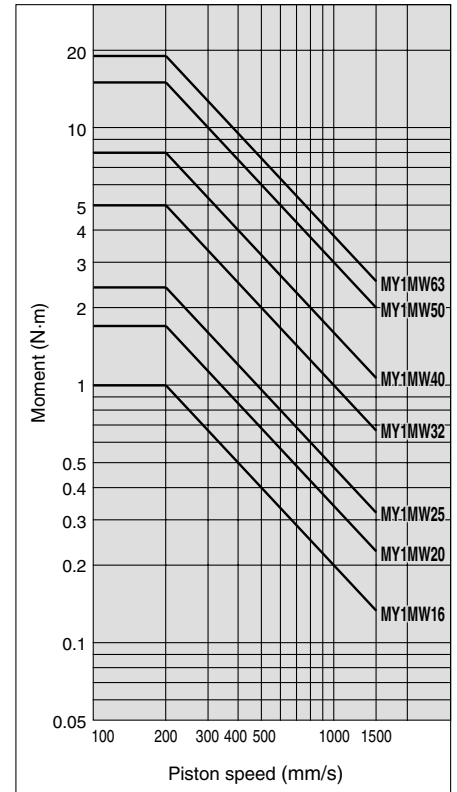

Maximum Load Mass: MY1MW

MY1MW/m₁

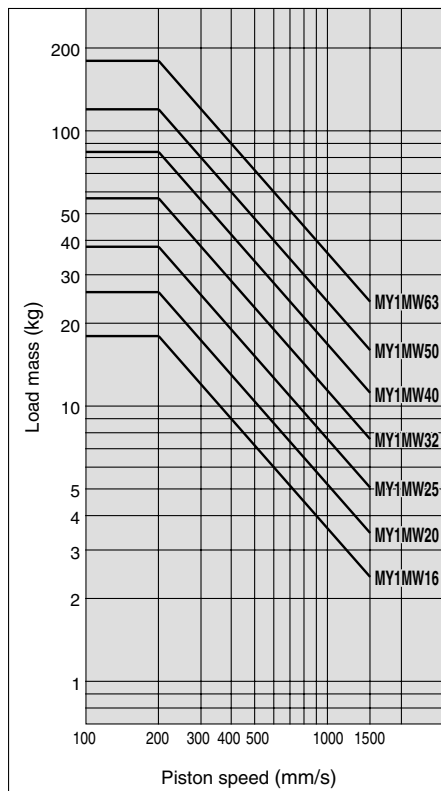

MY1MW/m₂

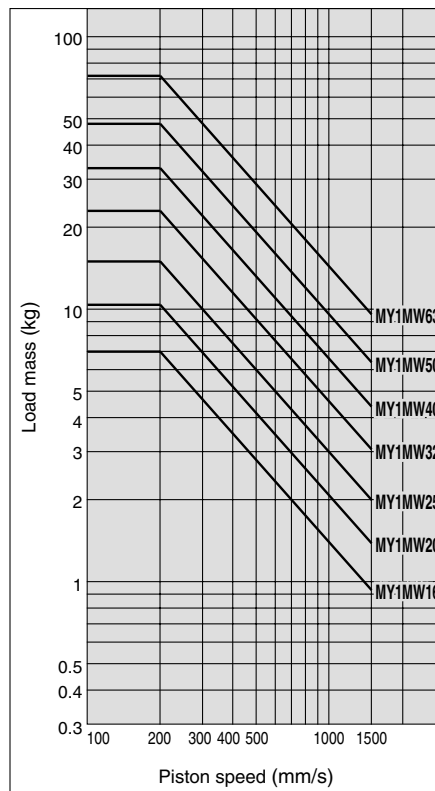

MY1MW/m₃

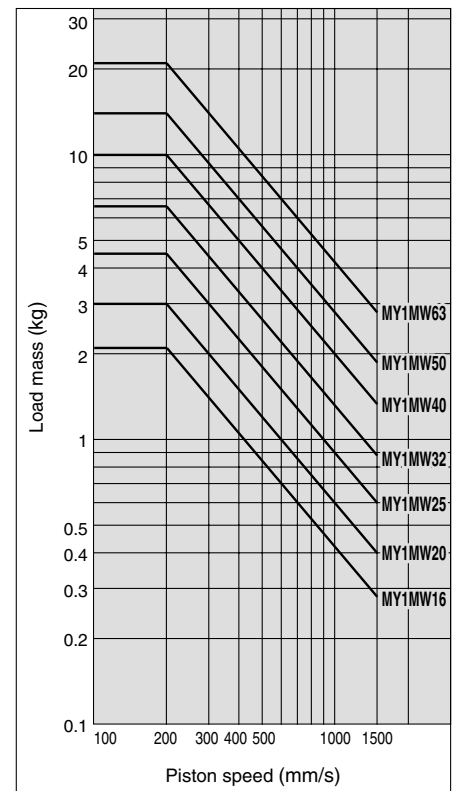

Maximum Allowable Moment: MY1CW

MY1CW/M₁

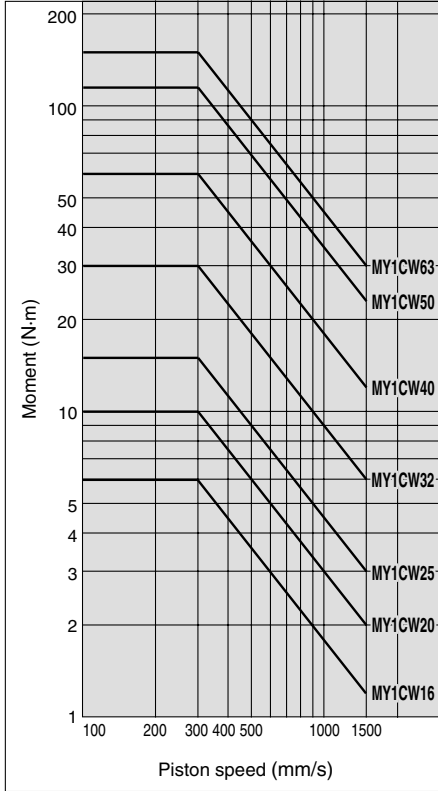

MY1CW/M₂

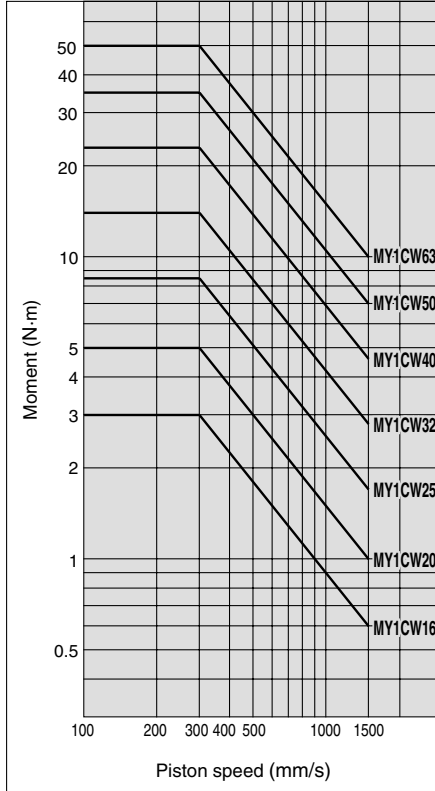

MY1CW/M₃

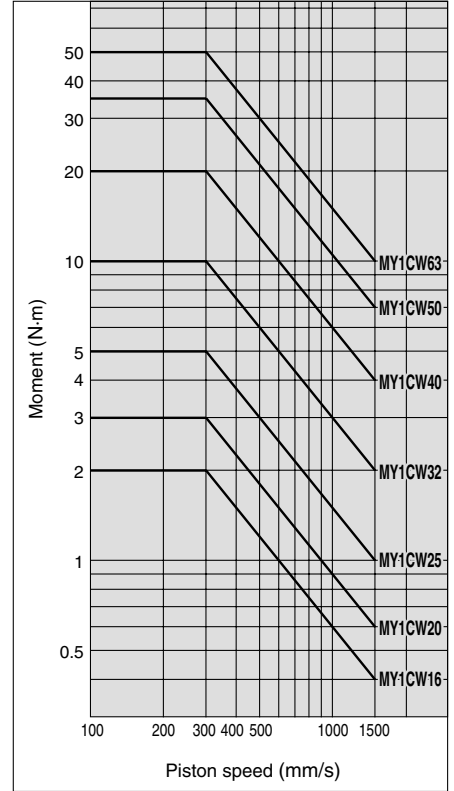

- MY1B
- MY1M
- MY1C
- MY1H
- MY1HT
- MY1□W**
- MY2C
- MY2H□
- MY3A
- MY3B
- MY3M

Maximum Load Mass: MY1CW

MY1CW/m₁

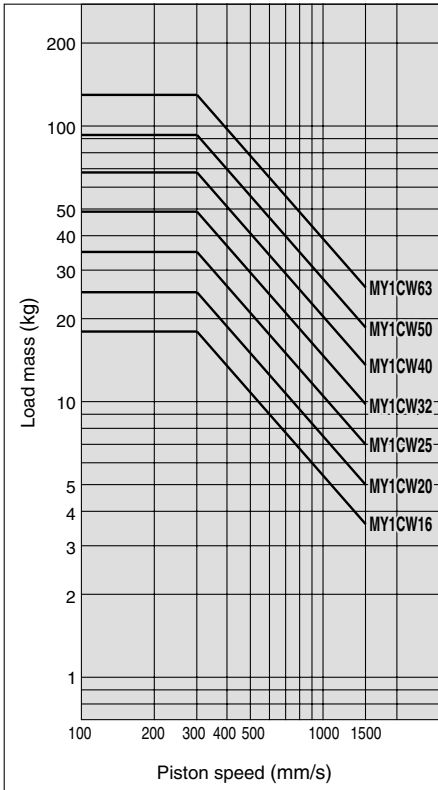

MY1CW/m₂

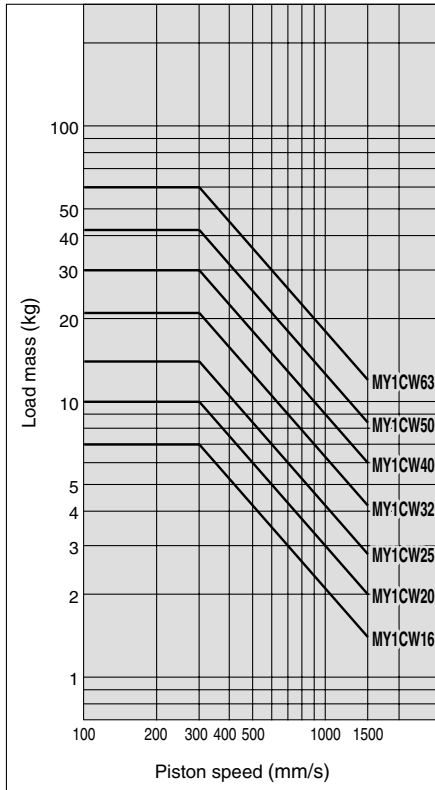

MY1CW/m₃

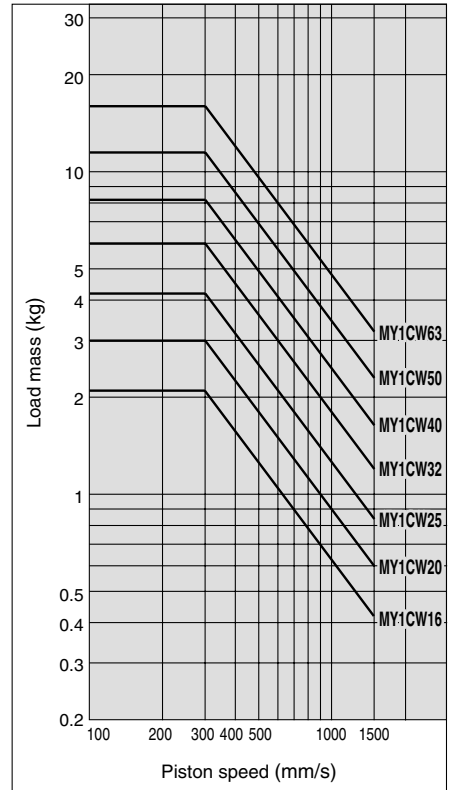

- D-□
- X□
- Individual
- X□
- Technical data

Cushion Capacity

Cushion Selection

<Air cushion>

Air cushions are a standard feature on mechanically jointed rodless cylinders.

The air cushion mechanism is incorporated to prevent excessive impact of the piston at the stroke end during high speed operation. The purpose of air cushion, thus, is not to decelerate the piston near the stroke end.

The ranges of load and speed that air cushions can absorb are within the air cushion limit lines shown in the graphs.

<Stroke adjusting unit with shock absorber>

Use this unit when operating with a load or speed exceeding the air cushion limit line, or when cushioning is required outside of the effective air cushion stroke range due to stroke adjustment.

L unit

Use this unit when the cylinder stroke is outside of the effective air cushion range even if the load and speed are within the air cushion limit line, or when the cylinder is operated in a load and speed range above the air cushion limit line or below the L unit limit line.

⚠ Caution

1. Refer to the figure below when using the adjusting bolt to perform stroke adjustment.

When the effective stroke of the shock absorber decreases as a result of stroke adjustment, the absorption capacity decreases dramatically. Secure the adjusting bolt at the position where it protrudes approximately 0.5 mm from the shock absorber.

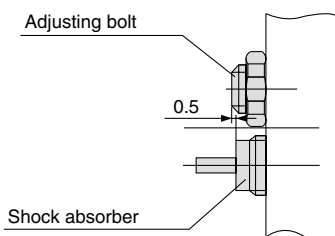

2. Do not use a shock absorber together with air cushion.

Air Cushion Stroke (mm)

Bore size (mm)	Cushion stroke
16	12
20	15
25	15
32	19
40	24
50	30
63	37

Absorption Capacity of Air Cushion and Stroke Adjusting Units

ø16 Horizontal collision: P = 0.5 MPa

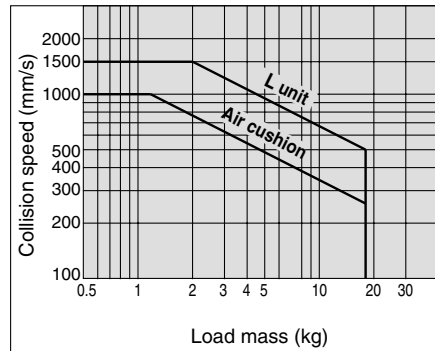

ø32 Horizontal collision: P = 0.5 MPa

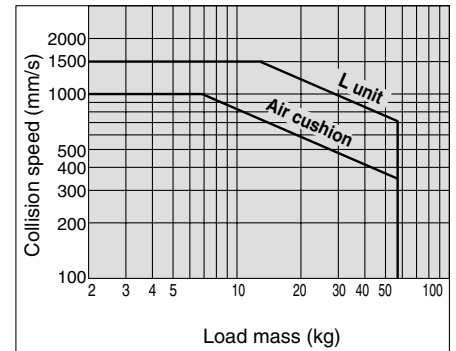

ø20 Horizontal collision: P = 0.5 MPa

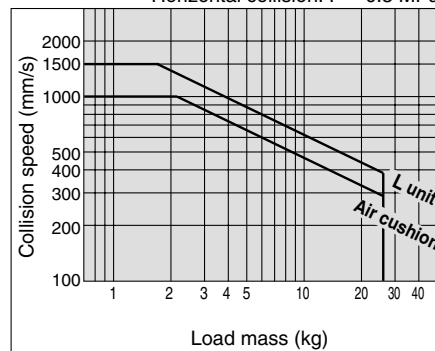

ø40 Horizontal collision: P = 0.5 MPa

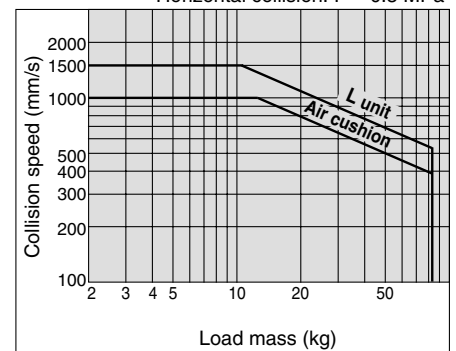

ø25 Horizontal collision: P = 0.5 MPa

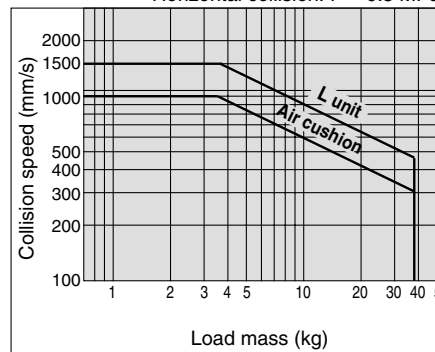

ø50 Horizontal collision: P = 0.5 MPa

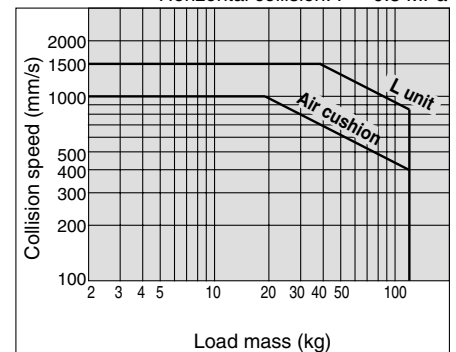

ø63 Horizontal collision: P = 0.5 MPa

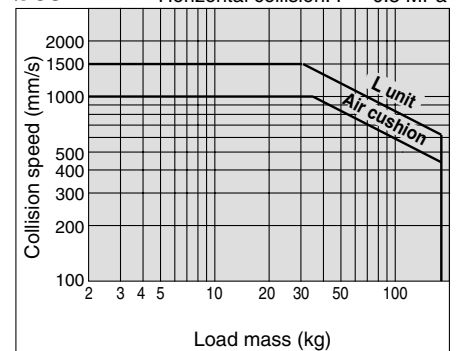

Tightening Torque for Stroke Adjusting Unit Holding Bolts (N·m)

Bore size (mm)	Unit	Tightening torque
16	A	0.7
	L	
20	A	1.8
	L	
25	A	3.5
	L	
32	A	5.8
	L	
40	A	13.8
	L	
50	A	13.8
	L	
63	A	27.5
	L	

Tightening Torque for Stroke Adjusting Unit Lock Plate Holding Bolts (N·m)

Bore size (mm)	Unit	Tightening torque
25	L	1.2
32	L	3.3
40	L	3.3

Calculation of Absorbed Energy for Stroke Adjusting Unit with Shock Absorber (N·m)

Type of impact	Horizontal collision	Vertical (Downward)	Vertical (Upward)
Kinetic energy E_1		$\frac{1}{2} m \cdot v^2$	
Thrust energy E_2	F·s	F·s + m·g·s	F·s - m·g·s
Absorbed energy E		$E_1 + E_2$	

Symbol

v: Speed of impact object (m/s)

m: Mass of impact object (kg)

F: Cylinder thrust (N)

g: Gravitational acceleration (9.8 m/s²)

s: Shock absorber stroke (m)

Note) The speed of the impact object is measured at the moment of impact with the shock absorber.

⚠ Precautions

Be sure to read before handling. Refer to front matters 54 and 55 for Safety Instructions and pages 3 to 11 for Actuator and Auto Switch Precautions.

⚠ Caution

Use caution not to get your hands caught in the unit.

- When using a product with stroke adjusting unit, the space between the slide table (slider) and the stroke adjusting unit becomes narrow at the stroke end, causing a danger of hands getting caught. When operating with the protective cover removed (in the case of installation, etc.), be careful not to get your hands caught in the unit.

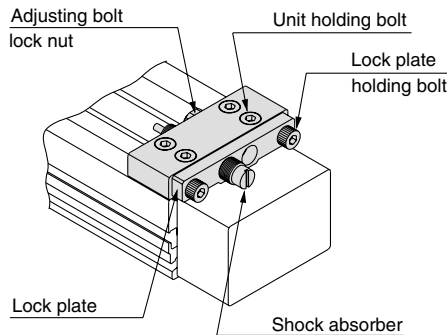

<Fastening of unit>

The unit can be secured by evenly tightening the four unit holding bolts.

⚠ Caution

Do not operate with the stroke adjusting unit fixed in an intermediate position.

When the stroke adjusting unit is fixed in an intermediate position, slippage can occur depending on the amount of energy released at the time of an impact. In such cases, the use of the adjusting bolt mounting brackets, available per made-to-order specifications -X416 and -X417, is recommended.

For other lengths, please consult with SMC (Refer to the "Tightening Torque for Stroke Adjusting Unit Holding Bolts" values in the chart at the upper left corner of this page.)

<Stroke adjustment with adjusting bolt>

Loosen the adjusting bolt lock nut, and adjust the stroke from the lock plate side using a hexagon wrench. Retighten the lock nut.

<Stroke adjustment with shock absorber>

Loosen the two lock plate holding bolts, turn the shock absorber and adjust the stroke. Then, uniformly tighten the lock plate holding bolts to secure the shock absorber.

Avoid excessive tightening of the holding bolts (except for ø16, ø20, ø50, and ø63). (Refer to "Tightening Torque for Stroke Adjusting Unit Lock Plate Holding Bolts" above left.)

Note)

Although the lock plate may slightly bend due to tightening of the lock plate holding bolt, this does not affect the shock absorber and locking function.

MY1B

MY1M

MY1C

MY1H

MY1HT

MY1□W

MY2C

MY2H□

MY3A

MY3B

MY3M

D-□

-X□

Individual
-X□

Technical
data

Model Selection 2

This section illustrates the standard model selection procedure using the actual operating conditions as one of the examples.

Calculation of Guide Load Factor

1 Operating Conditions

CylinderMY1MW40-500

Average operating speed U_a 200 mm/s

Mounting orientationHorizontal mounting

Wa: Connection plate $t = 10$ (880 g)

Wd: Workpiece (500 g)

Wc: MHL2-16D1(795 g)

MY1MW40-500

Wb: MGGLB25-200 (4.35 kg)

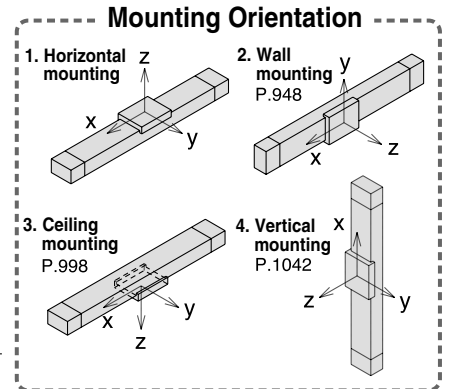
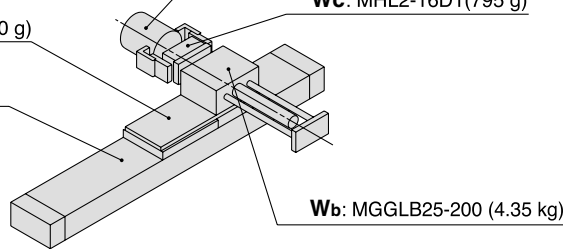

For actual examples of calculation for each orientation, refer to the pages above.

2 Load Blocking

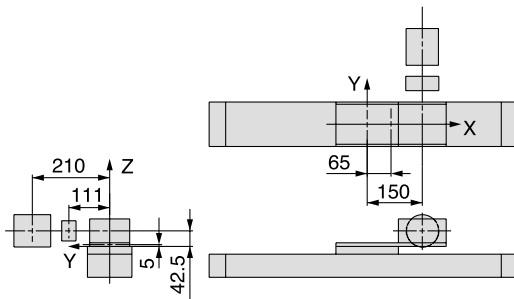

Mass and Center of Gravity for Each Workpiece

Workpiece no. W_n	Mass m_n	Center of gravity		
		X-axis X_n	Y-axis Y_n	Z-axis Z_n
Wa	0.88 kg	65 mm	0 mm	5 mm
Wb	4.35 kg	150 mm	0 mm	42.5 mm
Wc	0.795 kg	150 mm	111 mm	42.5 mm
Wd	0.5kg	150 mm	210 mm	42.5 mm

$n = a, b, c, d$

3 Composite Center of Gravity Calculation

$$m_1 = \sum m_n$$

$$= 0.88 + 4.35 + 0.795 + 0.5 = \mathbf{6.525 \text{ kg}}$$

$$X = \frac{1}{m_1} \times \sum (m_n \times x_n)$$

$$= \frac{1}{6.525} (0.88 \times 65 + 4.35 \times 150 + 0.795 \times 150 + 0.5 \times 150) = \mathbf{138.5 \text{ mm}}$$

$$Y = \frac{1}{m_1} \times \sum (m_n \times y_n)$$

$$= \frac{1}{6.525} (0.88 \times 0 + 4.35 \times 0 + 0.795 \times 111 + 0.5 \times 210) = \mathbf{29.6 \text{ mm}}$$

$$Z = \frac{1}{m_1} \times \sum (m_n \times z_n)$$

$$= \frac{1}{6.525} (0.88 \times 5 + 4.35 \times 42.5 + 0.795 \times 42.5 + 0.5 \times 42.5) = \mathbf{37.4 \text{ mm}}$$

4 Calculation of Load Factor for Static Load

m_1 : Mass

$m_1 \text{ max}$ (from 1 of graph MY1MW/ m_1) = 84 (kg)

Load factor $\alpha_1 = m_1 / m_1 \text{ max} = 6.525 / 84 = \mathbf{0.08}$

M_1 : Moment

$M_1 \text{ max}$ (from (2) of graph MY1MW/ M_1) = 59 (N·m)

$M_1 = m_1 \times g \times X = 6.525 \times 9.8 \times 138.5 \times 10^{-3} = 8.86 \text{ (N·m)}$

Load factor $\alpha_2 = M_1 / M_1 \text{ max} = 8.86 / 59 = \mathbf{0.15}$

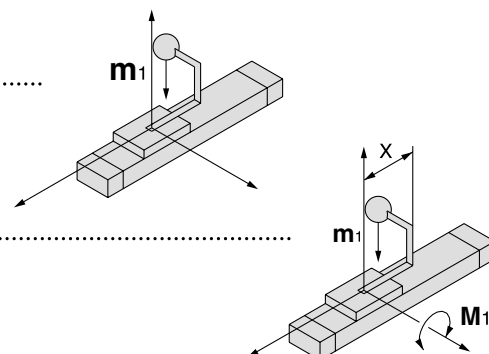

Calculation of Guide Load Factor

M₂: Moment

M_{2max} (from 3 of graph MY1MW: **M₂**) = 24 (N·m)

M₃ = **m₁** × **g** × **Y** = 6.525 × 9.8 × 29.6 × 10⁻³ = 1.89 (N·m)

Load factor **α₃** = **M₂/M_{2max}** = 1.89/24 = **0.08**

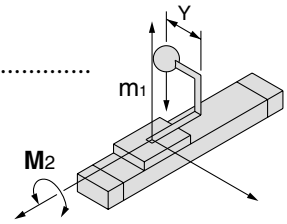

5 Calculation of Load Factor for Dynamic Moment

Equivalent load F_E at impact

$$F_E = \frac{1.4}{100} \times 1.4 \times g \times m = \frac{1.4}{100} \times 200 \times 9.8 \times 6.525 = 179.1 \text{ (N)}$$

M_{1E}: Moment

M_{1E}max (from 4 of graph MY1MW: **M₁** where 1.4U_a = 280 mm/s) = 42.1 (N·m)

$$M_{1E} = \frac{1}{3} \times F_E \times Z = \frac{1}{3} \times 179.1 \times 37.4 \times 10^{-3} = 2.23 \text{ (N·m)}$$

Load factor **α₄** = **M_{1E}/M_{1E}max** = 2.23/42.1 = **0.05**

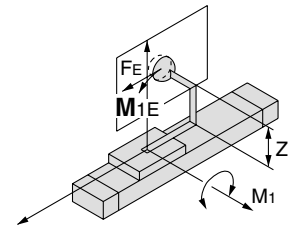

M_{3E}: Moment

M_{3E}max (from 5 of graph MY1MW: **M₃** where 1.4U_a = 280 mm/s) = 5.7 (N·m)

$$M_{3E} = \frac{1}{3} \times F_E \times Y = \frac{1}{3} \times 179.1 \times 29.6 \times 10^{-3} = 1.77 \text{ (N·m)}$$

Load factor **α₅** = **M_{3E}/M_{3E}max** = 1.77/5.7 = **0.31**

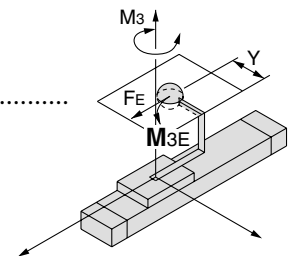

MY1B

MY1M

MY1C

MY1H

MY1HT

MY1□W

MY2C

MY2H□

MY3A

MY3B

MY3M

6 Sum and Examination of Guide Load Factors

$$\sum \alpha = \alpha_1 + \alpha_2 + \alpha_3 + \alpha_4 + \alpha_5 = 0.67 \leq 1$$

The above calculation is within the allowable value, and therefore the selected model can be used.

Select a shock absorber separately.

In an actual calculation, when the total sum of guide load factors $\sum \alpha$ in the formula above is more than 1, consider either decreasing the speed, increasing the bore size, or changing the product series. This calculation can be easily made using the "SMC Pneumatics CAD System".

Load Mass

MY1MW/m₁

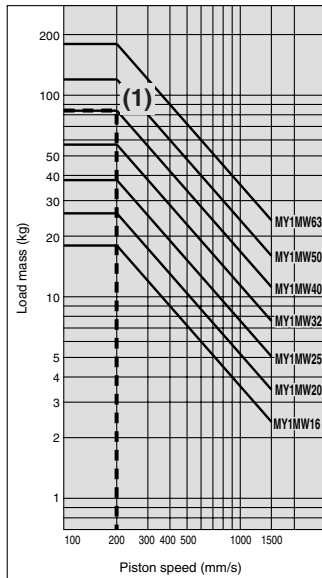

Allowable Moment

MY1MW/M₁

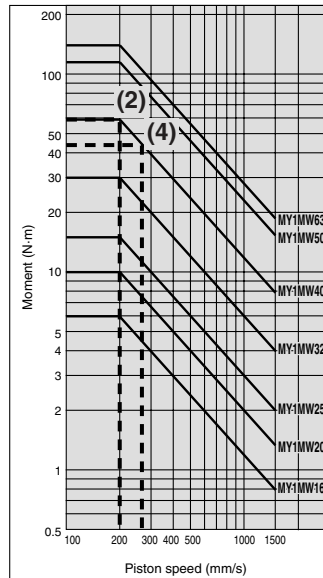

MY1MW/M₂

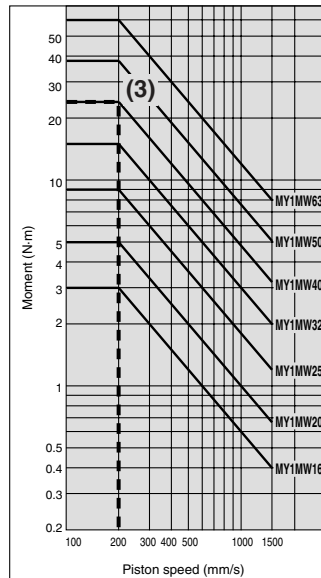

MY1MW/M₃

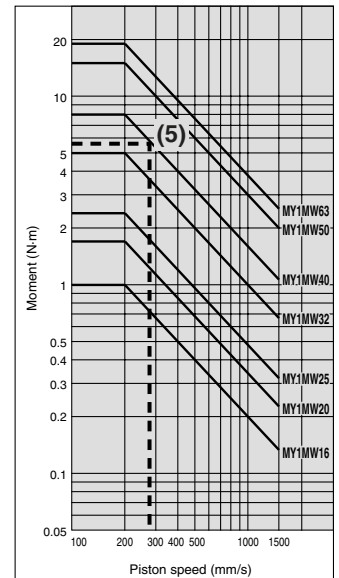

D-□

-X□

Individual

-X□

Technical data

Mechanically Jointed Rodless Cylinder with Protective Cover Slide Bearing Guide Type, Cam Follower Guide Type

Series MY1□W

ø16, ø20, ø25, ø32, ø40, ø50, ø63

How to Order

MY1 M W K 32 - **300** - **M9BW**

Guide type

M	Slide bearing guide type
C	Cam follower guide type

With protective cover

Side seal

Nil	None
K	With side seal

Note) Cylinders with side seal are available for ø16 to ø40.

Port thread type

Symbol	Type	Tube size
Nil	M thread	ø16, ø20
	Rc	ø25, ø32,
TN	NPT	ø40, ø50,
TF	G	ø63

Stroke adjusting unit

Nil	Both ends
S	One end

Note) "S" is available when stroke adjusting units are A and L.

Auto switch

Nil	Without auto switch (Built-in magnet)
-----	---------------------------------------

Applicable auto switches vary depending on the bore size. Select an applicable one referring to the table below.

Stroke adjusting unit

Nil	Without adjusting unit
A	With adjusting bolt
L	With low load shock absorber + Adjusting bolt
AL	With one A unit and one L unit

Number of auto switches

Nil	2 pcs
S	1 pc
n	"n" pcs

Bore size

16	16 mm
20	20 mm
25	25 mm
32	32 mm
40	40 mm
50	50 mm
63	63 mm

Piping

Nil	Standard type
G	Centralized piping type

Cylinder stroke (mm)

Refer to "Standard Stroke" on page 1069.

Shock Absorbers for L Unit

Unit no.	Bore size (mm)	16	20	25	32	40	50	63
L unit		RB0806	RB1007	RB1412			RB2015	

Made to Order Specifications

For details, refer to page 1069.

Applicable Auto Switch / Refer to pages 1263 to 1371 for further information on auto switches.

Type	Special function	Electrical entry	Indicator/light	Wiring (Output)	Load voltage		Auto switch model						Lead wire length (m)				Pre-wired connector	Applicable load	
					DC	AC	Perpendicular			In-line			0.5 (Nil)	1 (M)	3 (L)	5 (Z)			
							ø16, ø20	ø25 to ø40	ø50, ø63	ø16, ø20	ø25 to ø40	ø50, ø63							
Solid state switch	—	Grommet	Yes	3-wire (NPN)	5 V, 12 V	—	—	M9NV** [Y69A]	—	M9N** [Y59A]	●	—	●	○	○	IC circuit	Relay PLC		
				3-wire (PNP)			—	M9PV** [Y7PV]	—	M9P** [Y7P]	●	—	●	○	○				
				2-wire	12 V	—	—	M9BV** [Y69B]	—	M9B** [Y59B]	●	—	●	○	○			—	
				3-wire (NPN)			24 V	5 V, 12 V	—	—	M9NVW** [Y7NWV]	—	M9NW** [Y7NW]	●	—				●
				3-wire (PNP)	—	M9PVW** [Y7PWV]				—	M9PW** [Y7PW]	●	—	●	○			○	
				2-wire	12 V	—	—	M9BWW** [Y7BWV]	—	M9BW** [Y7BW]	●	—	●	○	○			—	
	Water resistant (2-color indication)	Grommet	No	Yes	3-wire (NPN)	5 V, 12 V	—	—	M9NAV**	—	M9NA**	○	○	●	○	○	IC circuit	—	
					3-wire (PNP)			—	M9PAV**	—	M9PA**	○	○	●	○	○			
					2-wire	12 V	—	—	M9BAV**	—	M9BA** [Y7BAL]	○	○	●	○	○	—		
					—			—	—	—	—	—	—	—	—	—		—	
Reed switch	—	Grommet	No	3-wire (NPN equivalent)	24 V	12 V	100 V	—	—	A96	Z76	●	—	●	—	IC circuit	—		
				2-wire				—	—	—	—	—	—	—	—			—	Relay PLC
				100 V or less	—	—	—	A90	Z80	●	—	●	—	—	—	IC circuit	—		

* Lead wire length symbols: 0.5 m.....Nil (Example) M9NW
1 m.....M (Example) M9NWM
3 m.....L (Example) M9NWL
5 m.....Z (Example) M9NWZ

* Solid state auto switches marked with "○" are produced upon receipt of order.
** D-M9□□□ type cannot be mounted on ø40 of MY1CW and ø25 and ø40 of MY1MW. Select auto switches in brackets.

* Refer to page 1078 for details on other applicable auto switches than listed above.
* For details about auto switches with pre-wired connector, refer to pages 1328 and 1329.
* Auto switches are shipped together (not assembled).

Mechanically Jointed Rodless Cylinder *Series MY1□W* With Protective Cover

Specifications

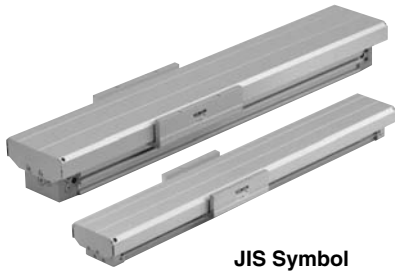

JIS Symbol

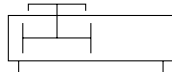

Bore size (mm)		16	20	25	32	40	50	63
Fluid		Air						
Action		Double acting						
Operating pressure range		MY1MW: 0.15 to 0.8 MPa; MY1CW: 0.1 to 0.8 MPa						
Proof pressure		1.2 MPa						
Ambient and fluid temperature		5 to 60°C						
Cushion		Air cushion						
Lubrication		Non-lube						
Stroke length tolerance		1000 or less ^{+1.8} ₀ 1001 to 3000 ^{+2.8} ₀		2700 or less ^{+1.8} ₀ ; 2701 to 3000 ^{+2.8} ₀				
Piping port size	Front/Side port	M5 x 0.8			Rc 1/8		Rc 1/4	Rc 3/8
	Bottom port	ø4			ø5	ø6	ø8	ø10, ø11

Stroke Adjusting Unit Specifications

Bore size (mm)	16		20		25		32		40		50		63	
Unit symbol	A	L	A	L	A	L	A	L	A	L	A	L	A	L
Configuration Shock absorber model	With adjusting bolt	RB 0806 with adjusting bolt	With adjusting bolt	RB 0806 with adjusting bolt	With adjusting bolt	RB 1007 with adjusting bolt	With adjusting bolt	RB 1412 with adjusting bolt	With adjusting bolt	RB 1412 with adjusting bolt	With adjusting bolt	RB 2015 with adjusting bolt	With adjusting bolt	RB 2015 with adjusting bolt
Fine stroke adjustment range (mm)	0 to -5.6		0 to -6		0 to -11.5		0 to -12		0 to -16		0 to -20		0 to -25	
Stroke adjustment range	When exceeding the stroke fine adjustment range: Utilize a made-to-order specifications "-X416" and "-X417".													

* Fine stroke adjustment range is applicable for one side when mounted on a cylinder.

Shock Absorber Specifications

Model	RB 0806	RB 1007	RB 1412	RB 2015	
Max. energy absorption (J)	2.9	5.9	19.6	58.8	
Stroke absorption (mm)	6	7	12	15	
Max. collision speed (mm/s)	1500				
Max. operating frequency (cycle/min)	80	70	45	25	
Spring force (N)	Extended	1.96	4.22	6.86	8.34
	Retracted	4.22	6.86	15.98	20.50
Operating temperature range (°C)	5 to 60				

* The shock absorber service life is different from that of the MY1□W cylinder depending on operating conditions. Refer to the Specific Product Precautions for the replacement period.

Piston Speed

Bore size (mm)		16 to 63
Without stroke adjusting unit		100 to 1000mm/s
Stroke adjusting unit	A unit	100 to 1000mm/s ⁽¹⁾
	L unit	100 to 1500mm/s ⁽²⁾

Note 1) The air cushion capacity will be reduced when the stroke adjustment range is increased by the adjusting bolt. When exceeding the air cushion stroke ranges on page 1064, the piston speed should be 100 to 200 mm per second.

Note 2) The piston speed is 100 to 1000 mm/s for centralized piping.

Note 3) Use at a speed within the absorption capacity range. Refer to page 1064.



Made to Order Specifications Standard Stroke

(For details, refer to pages 1395 and 1565.)

Symbol	Specifications
-XB11	Long stroke type
-XC67	NBR rubber lining in dust seal band
-X416	Holder mounting bracket I
-X417	Holder mounting bracket II

Bore size (mm)	Standard stroke (mm)*	Maximum manufacturable stroke (mm)
16, 20, 25, 32 40, 50, 63	100, 200, 300, 400, 500, 600, 700 800, 900, 1000, 1200, 1400, 1600 1800, 2000	3000

* Strokes are manufacturable in 1 mm increments, up to the maximum stroke. However, when exceeding a 2000 mm stroke, specify "-XB11" at the end of the model number. For details, refer to the "Made to Order Specifications".

MY1B

MY1M

MY1C

MY1H

MY1HT

MY1□W

MY2C

MY2H□

MY3A

MY3B

MY3M

D-□

-X□

Individual -X□

Technical data

Series MY1□W

Theoretical Output

(N)

Bore size (mm)	Piston area (mm ²)	Operating pressure (MPa)						
		0.2	0.3	0.4	0.5	0.6	0.7	0.8
16	200	40	60	80	100	120	140	160
20	314	62	94	125	157	188	219	251
25	490	98	147	196	245	294	343	392
32	804	161	241	322	402	483	563	643
40	1256	251	377	502	628	754	879	1005
50	1962	392	588	784	981	1177	1373	1569
63	3115	623	934	1246	1557	1869	2180	2492

Mass

(kg)

Bore size (mm)	MY1MW		MY1CW		Side support mass (per set)	Stroke adjusting unit mass (per unit)	
	Basic mass	Additional mass per each 50mm of stroke	Basic mass	Additional mass per each 50mm of stroke	Type A and B	A unit mass	L unit mass
16	1.25	0.16	1.25	0.16	0.01	0.03	0.04
20	1.90	0.19	1.85	0.18	0.02	0.04	0.05
25	2.56	0.28	2.50	0.28	0.02	0.07	0.11
32	4.75	0.43	4.62	0.42	0.04	0.14	0.23
40	7.79	0.61	7.51	0.57	0.08	0.25	0.34
50	13.53	0.83	13.61	0.82	0.08	0.36	0.51
63	21.84	1.18	21.94	1.17	0.17	0.68	0.83

Calculation: (Example) MY1MW25-300A

- Basic mass 2.56 kg
- Additional mass 0.28 kg per 50 st
- Mass of A unit 0.07 kg
- Cylinder stroke.....300 st
- $2.56 + 0.28 \times 300 \div 50 + 0.07 \times 2 \approx 4.38$ kg

Option

Stroke Adjusting Unit Part No.

Unit no.		Bore size (mm)							
		16	20	25	32	40	50	63	
A unit	Left	MYM-A16A1	MYM-A20A1	MYM-A25A1	MYM-A32A1	MYM-A40A1	MYM-A50A1	MYM-A63A1	
	Right	MYM-A16A2	MYM-A20A2	MYM-A25A2	MYM-A32A2	MYM-A40A2	MYM-A50A2	MYM-A63A2	
L unit	Left	MYM-A16L1	MYM-A20L1	MYM-A25L1	MYM-A32L1	MYM-A40L1	MYM-A50L1	MYM-A63L1	
	Right	MYM-A16L2	MYM-A20L2	MYM-A25L2	MYM-A32L2	MYM-A40L2	MYM-A50L2	MYM-A63L2	

Form and mounting direction of stroke adjusting unit

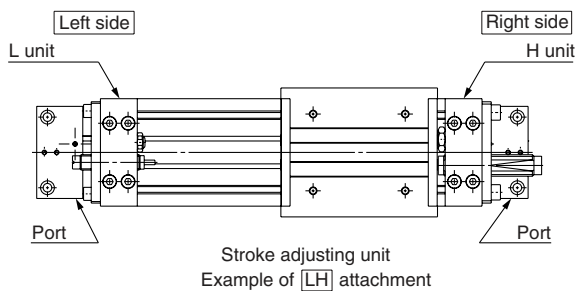

Side Support Part No.

Type \ Bore size (mm)	16	20	25	32	40	50	63
Side support A	MY-S16A	MY-S20A	MY-S25A	MY-S32A	MY-S40A		MY-S63A
Side support B	MY-S16B	MY-S20B	MY-S25B	MY-S32B	MY-S40B		MY-S63B

For detailed dimensions, refer to page 1076.

A set of side supports consists of a left support and a right support.

Mechanically Jointed Rodless Cylinder With Protective Cover **Series MY1□W**

Construction

MY1□W

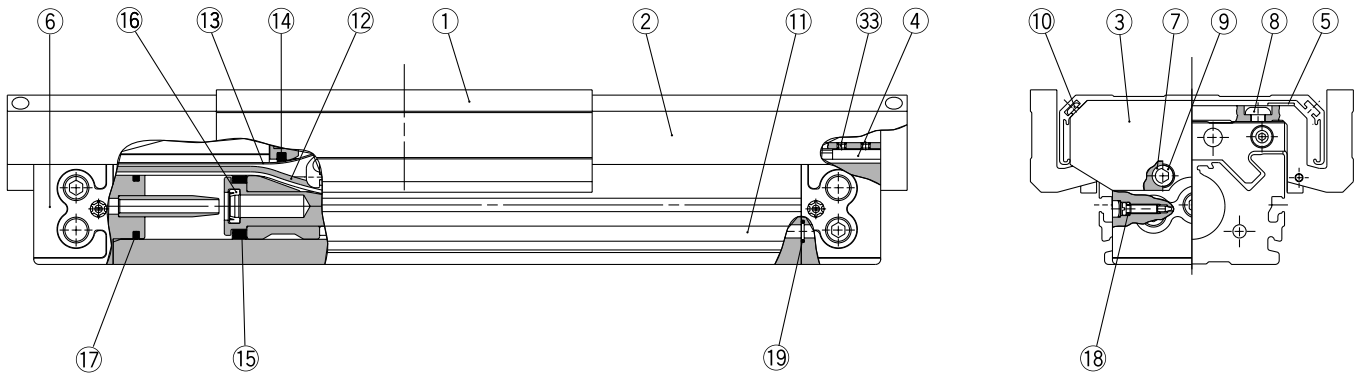

MY1□WK with side seal

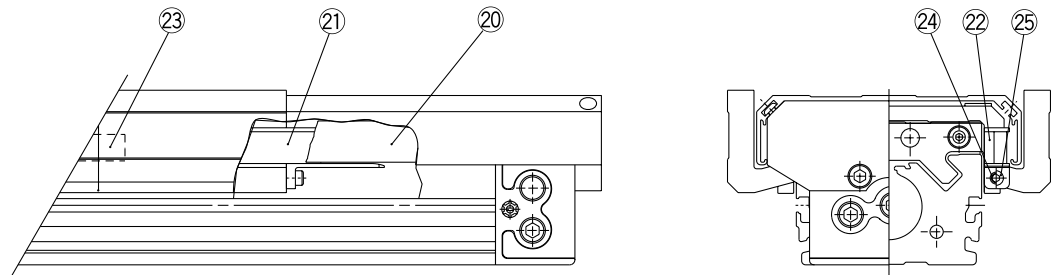

Component Parts

No.	Description	Material	Note	ø16	ø20	ø25	ø32	ø40	ø50	ø63
1	Slide table	Aluminum alloy	Hard anodized							
2	Cover	Aluminum alloy	Hard anodized							
3	End plate	Aluminum alloy	Hard anodized							
4	Belt clamp	Special resin								
5	Slide plate	Special resin		MYMW-16-Stroke	MYMW-20-Stroke	MYMW-25-Stroke	MYMW-32-Stroke	MYMW-40-Stroke	MYMW-50-Stroke	MYMW-63-Stroke
6	Port cover	Special resin	(ø25 to ø40)							
7	Spacer	Stainless steel	(ø25 to ø40)							
8	Hexagon socket button head screw	Chromium molybdenum steel	Nickel plated							
9	Hexagon socket head cap screw	Chromium molybdenum steel	Nickel plated							
10	Hexagon socket button head screw	Chromium molybdenum steel	Nickel plated							
11	Rodless cylinder	—	MY1M/MY1C	—	—	—	—	—	—	—
21	Seal guide A	Special resin								
22	Seal guide B	Special resin								
23	Slide plate	Special resin		MYMK-16-A	MYMK-16-A	MYMK-25-A	MYMK-25-A	MYMK-25-A	—	—
24	Spacer	Stainless steel								
25	Hexagon socket head cap screw	Chromium molybdenum steel	Nickel plated							

Replacement Parts: Seal Kit

No.	Description	Qty.	ø16	ø20	ø25	ø32	ø40	ø50	ø63
12	Seal belt	1	MY16-16A-Stroke	MY20-16A-Stroke	MY25-16A-Stroke	MY32-16A-Stroke	MY40-16A-Stroke	MY50-16A-Stroke	MY63-16A-Stroke
13	Dust seal band <small>(Note)</small>	1	MY16-16B-Stroke	MY20-16B-Stroke	MY25-16B-Stroke	MY32-16B-Stroke	MY40-16B-Stroke	MY50-16B-Stroke	MY63-16B-Stroke
18	O-ring	2	ø4 x ø1.8 x ø1.1	ø5.1 x ø3 x ø1.05	ø5.1 x ø3 x ø1.05	ø7.15 x ø3.75 x ø1.7	ø8.3 x ø4.5 x ø1.9	C4	C4
20	Side seal assembly	2	MYMK-16-Stroke	MYMK-20-Stroke	MYMK-25-Stroke	MYMK-32-Stroke	MYMK-40-Stroke	—	—
14	Scraper	2							
15	Piston seal	2							
16	Cushion seal	2	MY1M16-PS	MY1M20-PS	MY1M25-PS	MY1M32-PS	MY1M40-PS	MY1M50-PS	MY1M63-PS
17	Tube gasket	2							
19	O-ring	4							

Note) Two kinds of dust seal bands are available. Verify the type to use, since the part number varies depending on the treatment of the hexagon socket head set screw 33 (Refer to the Construction of MY1M on pages 986 and 987.).

A Black zinc chromated → MY□□-16B-Stroke B Nickel plated → MY□□-16BW-Stroke

* Seal kit includes 14, 15, 16, 17 and 19. Order the seal kit based on each bore size.

* Seal kit includes a grease pack (10 g).

When 12 and 13 are shipped as single units, a grease pack (10 g per 1000 strokes) is included.

Order with the following part number when only the grease pack is needed. **GR-S-010** (10 g), **GR-S-020** (20 g)

MY1B

MY1M

MY1C

MY1H

MY1HT

MY1□W

MY2C

MY2H□

MY3A

MY3B

MY3M

D-□

-X□

Individual

-X□

Technical

data

Series MY1□W

Dimensions: $\phi 16, \phi 20$

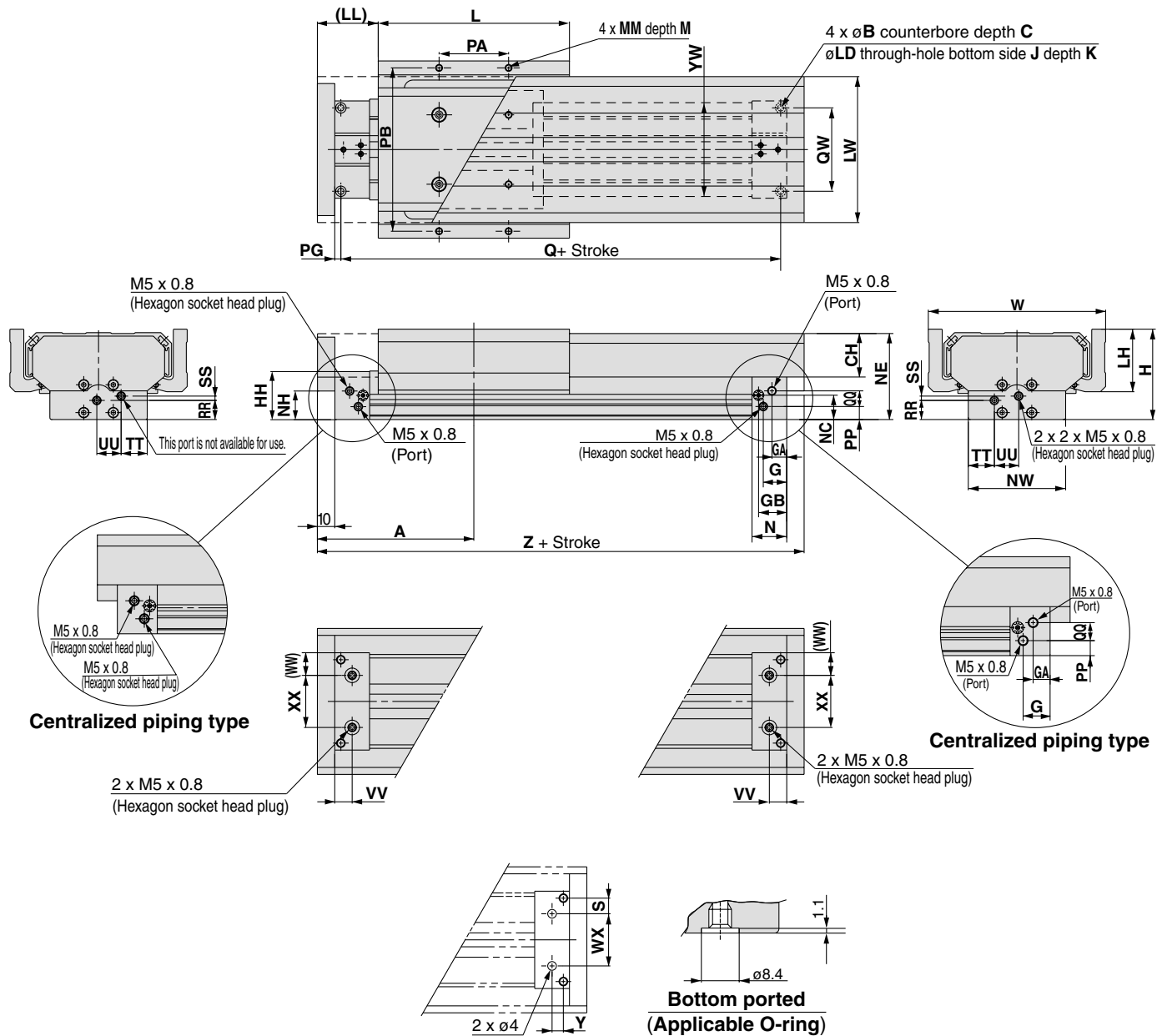

Bore size (mm)	A	B	C	CH	G	GA	GB	H	HH	J	K	L	LD	LH	LL	LW	M	MM	N	NC	NE	NH
16	90	6	3.5	25	13.5	8.5	16.2	52	27.7	M5 x 0.8	10	110	3.6	38	35	84	6	M4 x 0.7	20	14	49.5	16.5
20	110	7.5	4.5	26	12.5	12.5	20	58	33.7	M6 x 1	12	130	4.8	39	45	88	7.5	M5 x 0.8	25	17	55.5	21.7

Bore size (mm)	NW	PA	PB	PG	PP	Q	QQ	QW	RR	SS	TT	UU	VV	W	WW	YW	Z	XX
16	56	40	94	3.5	7.5	153	9	48	11	2.5	15	14	10	102	13	54	180	30
20	60	50	100	4.5	11.5	191	10	45	14.5	5	18	12	12.5	110	14	58	220	32

Hole Size for Centralized Piping on the Bottom

(Mounting side should be machined to these dimensions.)

Bore size (mm)	S	WX	Y	Applicable O-ring
16	9	30	6.5	C6
20	6.5	32	8	C6

Mechanically Jointed Rodless Cylinder With Protective Cover *Series MY1□W*

Dimensions: $\phi 25$, $\phi 32$, $\phi 40$

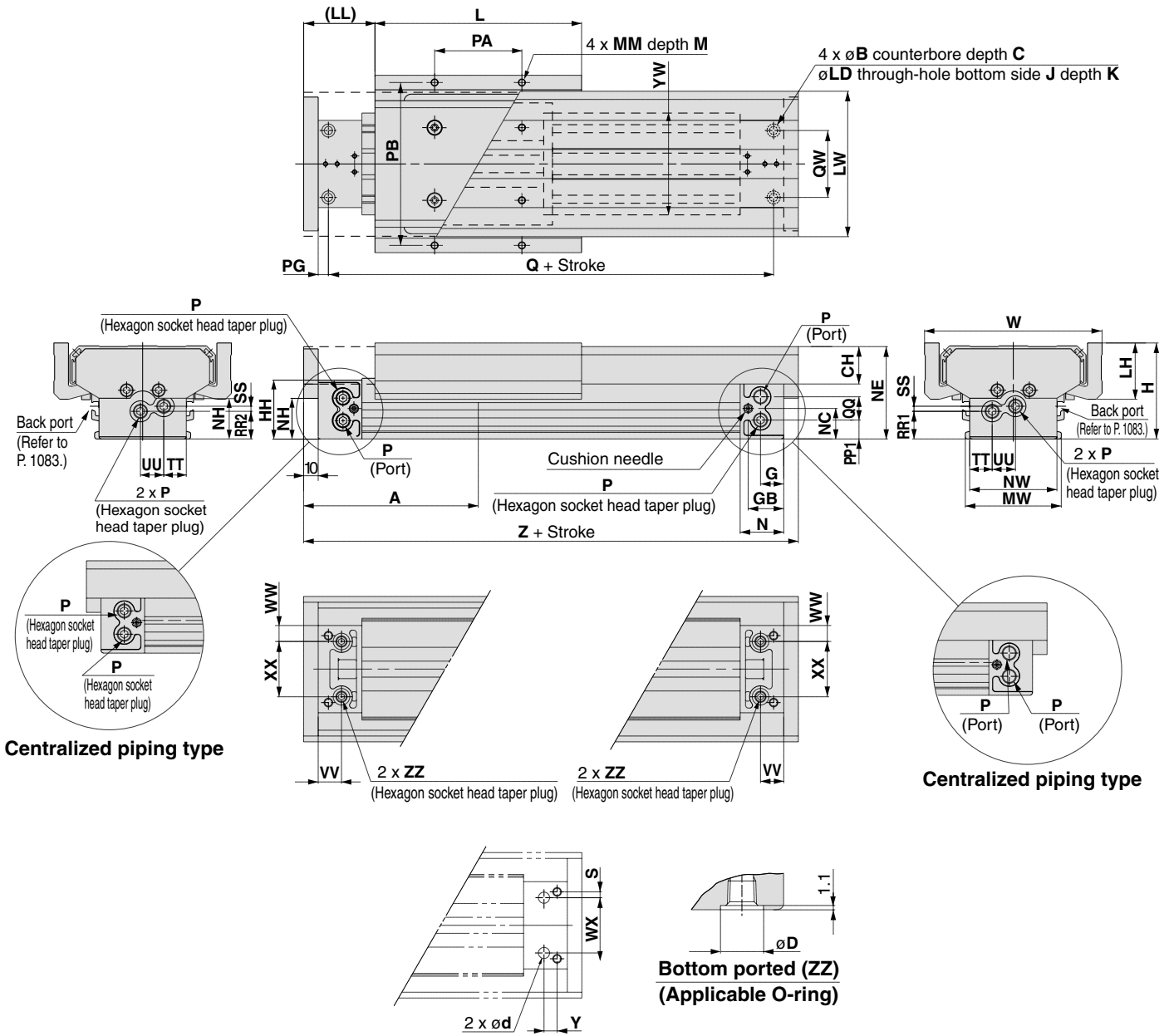

- MY1B
- MY1M
- MY1C
- MY1H
- MY1HT
- MY1□W**
- MY2C
- MY2H□
- MY3A
- MY3B
- MY3M

Centralized piping type

Centralized piping type

**Bottom ported (ZZ)
(Applicable O-ring)**

Bore size (mm)	A	B	C	CH	G	GB	H	HH	J	K	L	LD	LH	LL	LW	M	MM	MW	N	NC	NE	NH
25	120	9	5.5	25.7	17	24.5	66	40.5	M6 x 1	9.5	142	5.6	38.7	49	100	10	M5 x 0.8	66	30	21	64	28
32	150	11	6.5	31.5	19	30	82	50	M8 x 1.25	16	172	6.8	44.2	64	122	13	M6 x 1	80	37	26	80	37
40	180	14	8.5	34.8	23	36.5	98	63.5	M10 x 1.5	15	202	8.6	47.2	79	138	13	M6 x 1	96	45	32	96	48

Bore size (mm)	NW	P	PA	PB	PG	PP1	PP2	Q	QQ	QW	RR1	RR2	SS	TT	UU	VV	W	WW	YW	Z	ZZ	XX
25	60	Rc1/8	60	112	7	12.7	12.7	206	16	46	18.9	17.9	5.1	15.5	16	16	122	11	70	240	Rc1/16	38
32	74	Rc1/8	80	134	8	15.5	18.5	264	16	60	22	24	4	21	16	19	144	13	88	300	Rc1/16	48
40	94	Rc1/4	100	150	9	17.5	20	322	26	72	25.5	29	9	26	21	23	160	20	104	360	Rc1/8	54

Hole Size for Centralized Piping on the Bottom
(Mounting side should be machined to these dimensions.)

Bore size (mm)	D	d	WX	Y	S	Applicable O-ring
25	11.4	6	38	9	4	C9
32	11.4	6	48	11	6	C9
40	13.4	8	54	14	9	C11.2

- D-□
- X□
- Individual -X□
- Technical data

Series MY1□W

Dimensions: $\phi 50$, $\phi 63$

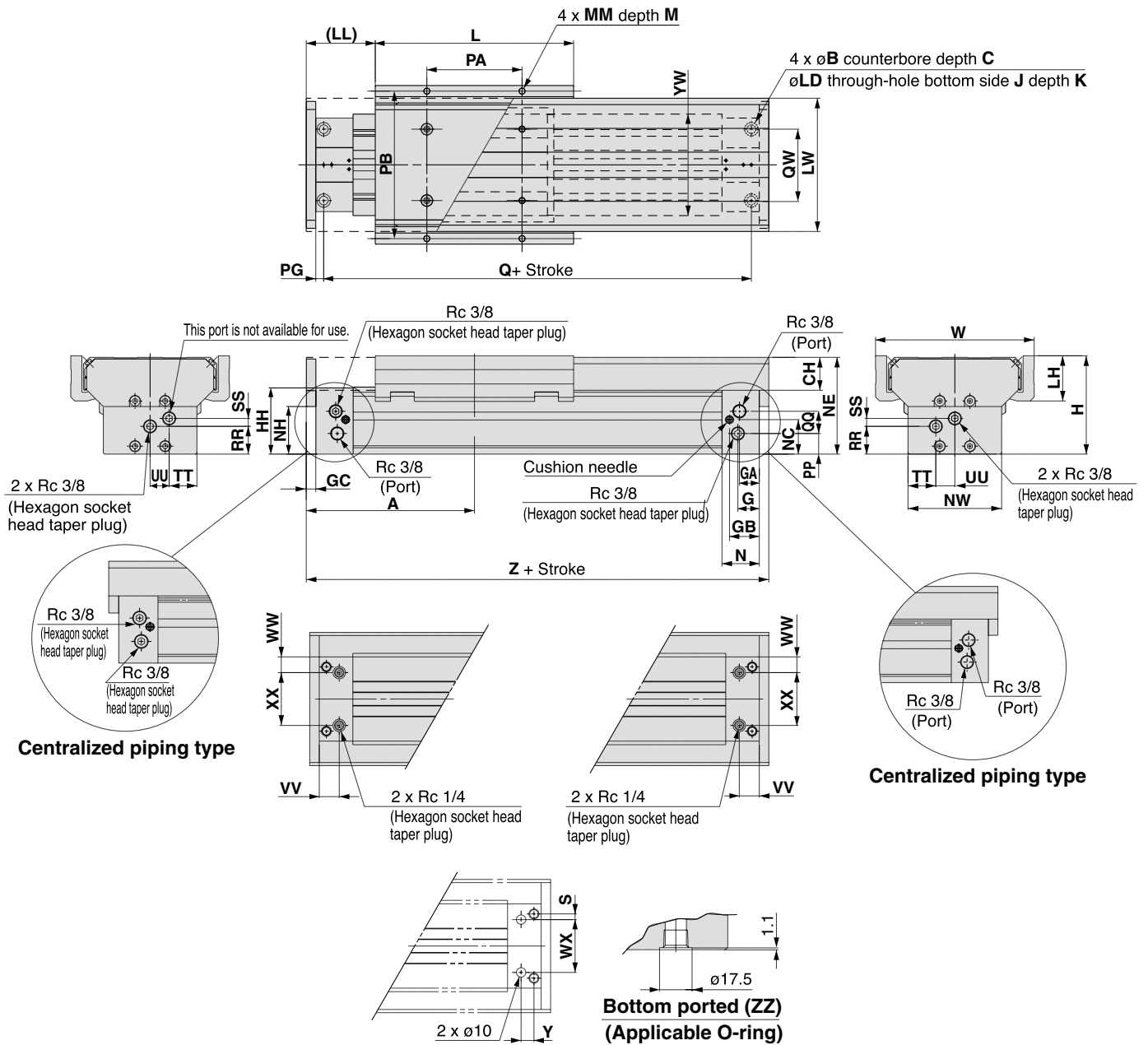

Bore size (mm)	A	B	C	CH	G	GA	GB	GC	H	HH	J	K	L	LD	LH	LL	LW	M	MM	N	NC	NE
50	212	17	10.5	41.5	27	25	37.5	12	124	83.5	M14 x 2	28	250	11	57	87	168	15	M8 x 1.25	47	44	122
63	245	19	12.5	47	29.5	27.5	39.5	15	149	105	M16 x 2	32	290	14	65	100	200	16	M10 x 1.25	50	60	147
Bore size (mm)	NH	NW	PA	PB	PG	PP	Q	QQ	QW	RR	SS	TT	UU	VV	W	WW	YW	Z	XX			
50	60	118	120	186	10	26	380	28	90	35	10	35	24	28	200	22	128	424	74			
63	70	142	140	220	12	42	436	30	110	49	13	43	28	30	236	25	152	490	92			

Hole Size for Centralized Piping on the Bottom

(Mounting side should be machined to these dimensions.)

Bore size (mm)	S	WX	Y	Applicable O-ring
50	8	74	18	C15
63	9	92	18	C15

Stroke Adjusting Unit

With adjusting bolt

MY1□W Bore size – Stroke A

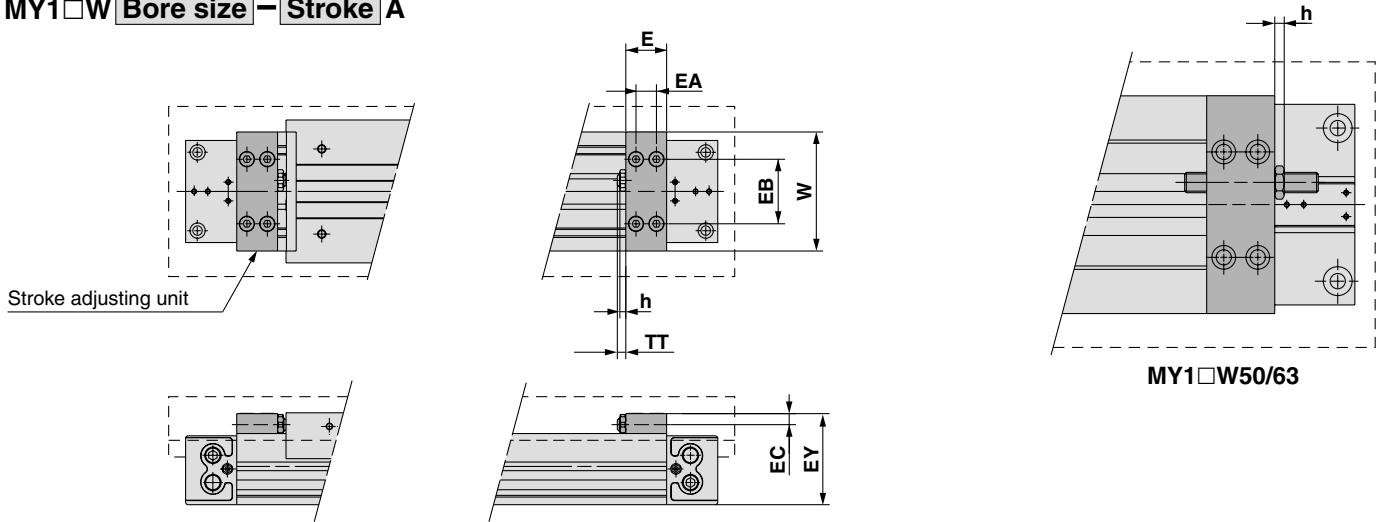

Model	E	EA	EB	EC	EY	h	TT	W
MY1□W16	14.6	7	30	5.8	39.5	3.6	5.4 (Max.11)	58
MY1□W20	20	10	32	5.8	45.5	3.6	5 (Max.11)	58
MY1□W25	24	12	38	6.5	53.5	3.5	5 (Max.16.5)	70
MY1□W32	29	14	50	8.5	67	4.5	8 (Max.20)	88
MY1□W40	35	17	57	10	83	4.5	9 (Max.25)	104
MY1□W50	40	20	66	14	106	5.5	13 (Max.33)	128
MY1□W63	52	26	77	14	129	5.5	13 (Max.38)	152

With low load shock absorber + Adjusting bolt

MY1□W Bore size – Stroke L

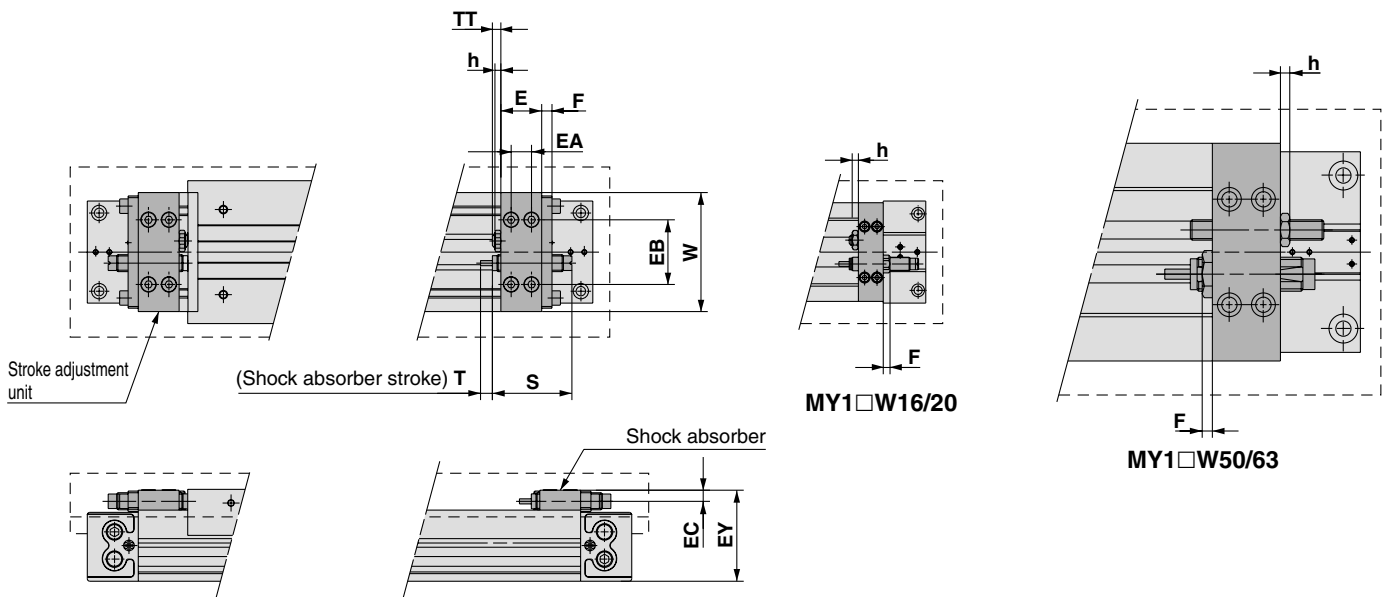

(mm)

Model	E	EA	EB	EC	EY	F	h	S	T	TT	W	Shock absorber model
MY1□W16	14.6	7	30	5.8	39.5	4	3.6	40.8	6	5.4 (Max.11)	58	RB0806
MY1□W20	20	10	32	5.8	45.5	4	3.6	40.8	6	5 (Max.11)	58	RB0806
MY1□W25	24	12	38	6.5	53.5	6	3.5	46.7	7	5 (Max.16.5)	70	RB1007
MY1□W32	29	14	50	8.5	67	6	4.5	67.3	12	8 (Max.20)	88	RB1412
MY1□W40	35	17	57	10	83	6	4.5	67.3	12	9 (Max.25)	104	RB1412
MY1□W50	40	20	66	14	106	6	5.5	73.2	15	13 (Max.33)	128	RB2015
MY1□W63	52	26	77	14	129	6	5.5	73.2	15	13 (Max.38)	152	RB2015

- MY1B
- MY1M
- MY1C
- MY1H
- MY1HT
- MY1□W
- MY2C
- MY2H□
- MY3A
- MY3B
- MY3M

- D-□
- X□
- Individual
- X□
- Technical data

Series MY1□W

Side Support

Side support A
MY-S□A

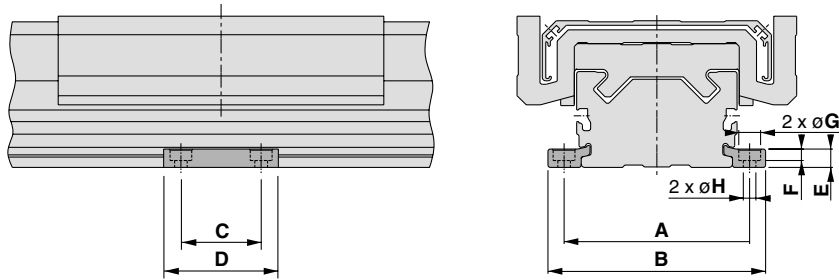

Side support B
MY-S□B

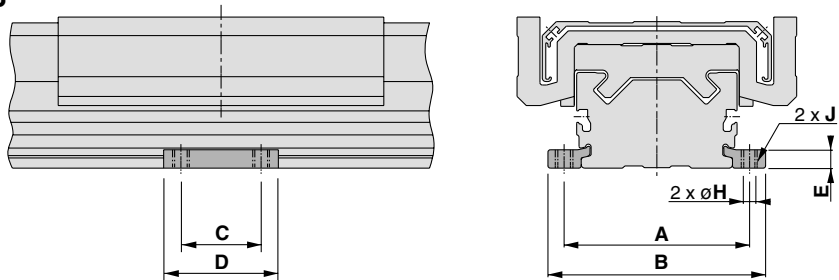

Model	Applicable cylinder	A	B	C	D	E	F	G	H	J
MY-S16 ^A _B	MY1□W16	61	71.6	15	26	4.9	3	6.5	3.4	M4 x 0.7
MY-S20 ^A _B	MY1□W20	67	79.6	25	38	6.4	4	8	4.5	M5 x 0.8
MY-S25 ^A _B	MY1□W25	81	95	35	50	8	5	9.5	5.5	M6 x 1
MY-S32 ^A _B	MY1□W32	100	118	45	64	11.7	6	11	6.6	M8 x 1.25
MY-S40 ^A _B	MY1□W40	120	142	55	80	14.8	8.5	14	9	M10 x 1.5
	MY1□W50	142	164							
MY-S63 ^A _B	MY1□W63	172	202	70	100	18.3	10.5	17.5	11.5	M12 x 1.75

* A set of side supports consists of a left support and a right support.

Guide for Side Support Application

For long stroke operation, the cylinder tube may be deflected depending on its own mass and the load mass. In such a case, use a side support in the middle section. The spacing (ℓ) of the support must be no more than the values shown in the graph on the right.

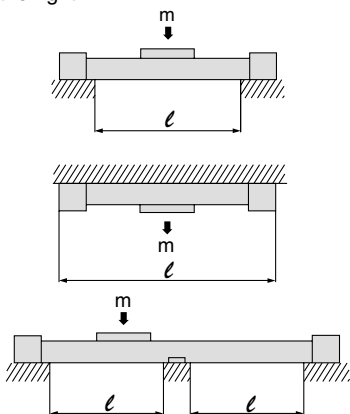

⚠ Caution

1. If the cylinder mounting surfaces are not measured accurately, using a side support may cause poor operation. Therefore, be sure to level the cylinder tube when mounting. Also, for long stroke operation involving vibration and impact, use of a side support is recommended even if the spacing value is within the allowable limits shown in the graph.
2. Support brackets are not for mounting; use them solely for providing support.

MY1MW

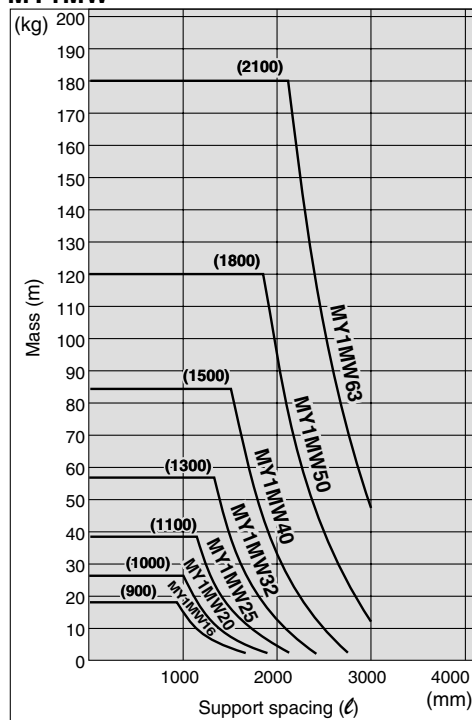

MY1CW

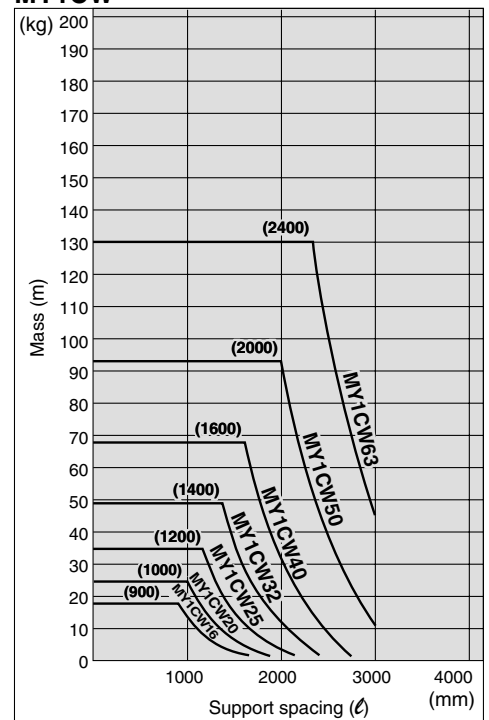

Proper Auto Switch Mounting Position (Detection at stroke end)

MY1MW (Slide bearing guide type)

ø16, ø20

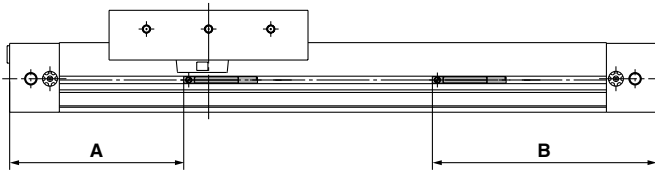

ø25, ø32, ø40, ø50, ø63

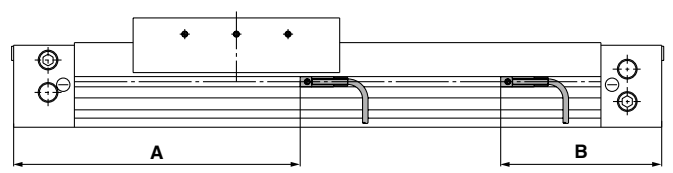

Proper Auto Switch Mounting Position

(mm)

Bore size (mm)	D-M9□ D-M9□W D-M9□AL		D-M9□V D-M9□WV D-M9□AVL		D-A9□ D-A9□V		D-Y69□/Y7PV D-Y7□WV		D-Z7□/Z80 D-Y59□/Y7P D-Y7□W D-Y7BAL	
	A	B	A	B	A	B	A	B	A	B
16	74	86	74	86	70	90	—	—	—	—
20	94	106	94	106	90	110	—	—	—	—
25	—	—	—	—	—	—	139.5	80.5	139.5	80.5
32	189.5	90.5	189.5	90.5	—	—	184.5	95.5	184.5	95.5
40	—	—	—	—	—	—	229.5	110.5	229.5	110.5
50	283.5	116.5	—	—	—	—	—	—	278.5	121.5
63	328.5	131.5	—	—	—	—	—	—	323.5	136.5

Note 1) D-M9□□□ type cannot be mounted on ø25 and ø40.

Note 2) Perpendicular electrical entry type and D-Y7BAL cannot be mounted on ø16, 20, 50 and 63. Consider using the in-line electrical entry type.

Note 3) Adjust the auto switch after confirming the operating conditions in the actual setting.

MY1CW (Cam follower guide type)

ø16, ø20

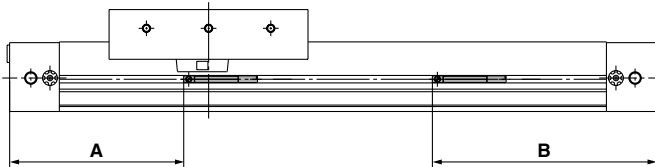

ø25, ø32, ø40, ø50, ø63

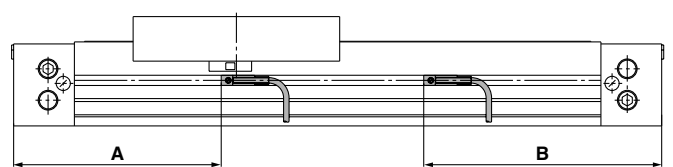

Proper Auto Switch Mounting Position

(mm)

Bore size (mm)	D-M9□ D-M9□W D-M9□AL		D-M9□V D-M9□WV D-M9□AVL		D-A9□ D-A9□V		D-Y69□/Y7PV D-Y7□WV		D-Z7□/Z80 D-Y59□/Y7P D-Y7□W D-Y7BAL	
	A	B	A	B	A	B	A	B	A	B
16	74	86	74	86	70	90	—	—	—	—
20	94	106	94	106	90	110	—	—	—	—
25	102	118	102	118	—	—	97	123	97	123
32	132	148	132	148	—	—	127	153	127	153
40	—	—	—	—	—	—	157.5	182.5	157.5	182.5
50	283.5	116.5	—	—	—	—	—	—	278.5	121.5
63	328.5	131.5	—	—	—	—	—	—	323.5	136.5

Note 1) D-M9□□□ type cannot be mounted on ø40.

Note 2) Perpendicular electrical entry type and D-Y7BAL cannot be mounted on ø16, 20, 50 and 63. Consider using the in-line electrical entry type.

Note 3) Adjust the auto switch after confirming the operating conditions in the actual setting.

MY1B

MY1M

MY1C

MY1H

MY1HT

MY1□W

MY2C

MY2H□

MY3A

MY3B

MY3M

D-□

-X□

Individual
-X□

Technical
data

Series MY1□W

Note) Since the operating range is provided as a guideline including hysteresis, it cannot be guaranteed. (Assuming approximately ±30% dispersion.) It may vary substantially depending on an ambient environment.

Operating range

MY1MW (Slide bearing guide type) (mm)

Auto switch model	Bore size						
	16	20	25	32	40	50	63
D-A9□/A9□V	11	7.5	—	—	—	—	—
D-M9□/M9□V D-M9□W/M9□WV D-M9□AL/M9□AVL	7.5	7.5	—	8.5	—	7	6
D-Z7□/Z80	—	—	12	12	12	11.5	11.5
D-Y59□/Y69□ D-Y7P/Y7PV D-Y7□W/Y7□WV D-Y7BAL	—	—	5	5	5	5.5	5.5

D-M9□□□ type cannot be mounted on ø25 and ø40.
Perpendicular electrical entry type and D-Y7BAL cannot be mounted on ø16, 20, 50 and 63. Consider using the in-line electrical entry type.

MY1CW (Cam follower guide type) (mm)

Auto switch model	Bore size						
	16	20	25	32	40	50	63
D-A9□/A9□V	11	7.5	—	—	—	—	—
D-M9□/M9□V D-M9□W/M9□WV D-M9□AL/M9□AVL	7.5	7.5	7	8	—	7	6
D-Z7□/Z80	—	—	12	12	12	11.5	11.5
D-Y59□/Y69□ D-Y7P/Y7PV D-Y7□W/Y7□WV D-Y7BAL	—	—	5	5	5	5.5	5.5

D-M9□□□ type cannot be mounted on ø40.
Perpendicular electrical entry type and D-Y7BAL cannot be mounted on ø16, 20, 50 and 63. Consider using the in-line electrical entry type.

Switch Mounting Bracket: Part No.

Auto switch model	Bore size (mm)	
	ø16, ø20	ø25 to ø63
D-M9□/M9□V D-M9□W/M9□WV D-M9□AL/M9□AVL	—	BMG2-012

ø25 to ø63: M9□(V)/M9□W(V)/M9□A(V)L

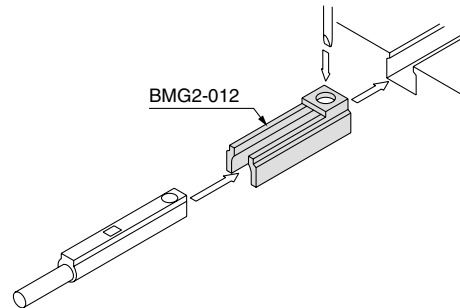

Besides the models listed in How to Order, the following auto switches are applicable. Refer to pages 1263 and 1371 for details.
For detailed specifications, refer to pages 1263 to 1371.

Type	Model	Electrical entry (Fetching direction)	Features	Applicable bore size
Solid state auto switch	D-Y69A, Y69B, Y7PV	Grommet (Perpendicular)	—	ø25 to ø40
	D-Y7NWV, Y7PWV, Y7BWV		Diagnostic indication (2-color indication)	
	D-Y59A, Y59B, Y7P	Grommet (In-line)	—	ø25 to ø63
	D-Y7NW, Y7PW, Y7BW		Diagnostic indication (2-color indication)	

* For solid state auto switches, auto switches with a pre-wired connector are also available. Refer to pages 1328 and 1329 for details.

* Normally closed (NC = b contact) solid state auto switches (D-F9G/F9H/Y7G/Y7H types) are also available. Refer to pages 1290 and 1292 for details.

Mounting of Auto Switch & Installation of Lead Wire Cover (ø50, ø63)

⚠ Caution

Be sure to install a lead wire cover on the auto switches for size ø50 and ø63 cylinders.

Install a lead wire cover following the procedures provided below to prevent the lead wire from interfering with the slider.

Lead wire cover is packaged together with size ø50 and ø63 cylinders equipped with auto switches.

For ordering the lead wire cover separately, use the following part number:
MYM63GAR6386-1640 (Length: 2 m)

1. Auto switch mounting position

Up to 4 auto switches can be mounted on one side of the cylinder (total of 8 switches on both sides).

When multiple auto switches are used, be sure to use the lead wire groove and pull the lead wires out from the edge of the cylinder. (Bold lines in Fig. (1) indicate lead wires.)

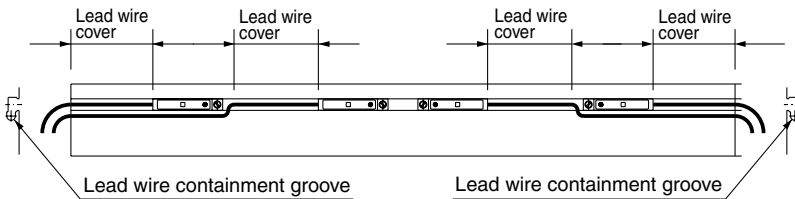

Fig. (1) Auto switch mounting position

2. How to mount auto switch/install lead wire cover

- 1) Insert and slide in the auto switch from the side of the cylinder and secure it with the screw provided. (Refer to Fig. (2).)
- 2) Cut the lead wire cover to the desired length using a cutter or tube cutter. (Refer to Fig. (1).)
- 3) First place the lead wires into the lead wire cover. Then, install a lead wire cover onto a cylinder body. (Refer to Fig. (3).)
- 4) Make sure that the lead wires do not interfere with the slide table at any stroke range.

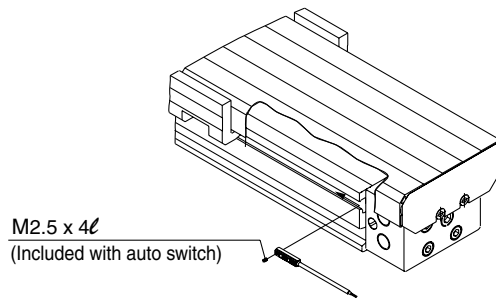

Fig. (2) Auto switch mounting

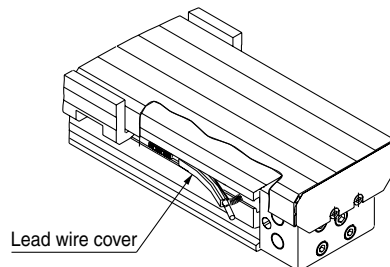

Fig. (3) Installation of lead wire cover

MY1B
MY1M
MY1C
MY1H
MY1HT
MY1□W
MY2C
MY2H□
MY3A
MY3B
MY3M

D-□
-X□
Individual -X□
Technical data



Series MY1□W

Specific Product Precautions 1

Be sure to read before handling.

Refer to front matters 54 and 55 for Safety Instructions and pages 3 to 11 for Actuator and Auto Switch Precautions.

Selection

⚠ Caution

1. When using a cylinder with long strokes, implement an intermediate support.

- When using a cylinder with long strokes, implement an intermediate support to prevent the tube from sagging and being deflected by vibration or an external load. Refer to the Guide for Side Support Application on page 1076.

2. For intermediate stops, use a dual-side pressure control circuit.

- Since the mechanically jointed rodless cylinders have a unique seal structure, slight external leakage may occur. Controlling intermediate stops with a 3 position valve cannot hold the stopping position of the slide table (slider). The speed at the restarting state also may not be controllable. Use the dual-side pressure control circuit with a PAB-connected 3 position valve for intermediate stops.

3. Constant speed

- Since the mechanically jointed rodless cylinders have a unique seal structure, a slight speed change may occur. For applications that require constant speed, select an applicable equipment for the level of demand.

4. Load factor of 0.5 or less

- When the load factor is high against the cylinder output, it may adversely affect the cylinder (condensation, etc.) and cause malfunctions. Select a cylinder to make the load factor less than 0.5. (Mainly when using an external guide)

5. Cautions on less frequent operation

- When the cylinder is used extremely infrequently, operation may be interrupted in order for anchoring and a change lubrication to be performed or service life may be reduced.

6. Consider uncalculated loads such as piping, cableveyor, etc., when selecting a load moment

- Calculation does not include the external acting force of piping, cableveyor, etc. Select load factors taking into account the external acting force of piping, cableveyor, etc.

7. Accuracy

- The mechanical jointed rodless cylinder does not guarantee traveling parallelism. When accuracy in traveling parallelism and a middle position of stroke is required, please consult with SMC.

Mounting

⚠ Caution

1. To obtain the best results from the cover, horizontal mounting is recommended.

- With horizontal mounting (shown below), the entry of dirt and dust from the bottom of the cover is much less compared to other mounting orientations, making it much more efficient.

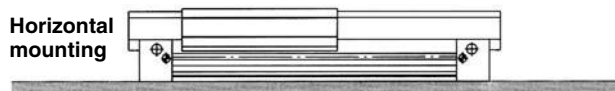

Mounting

⚠ Caution

2. When the cylinder is mounted from the top side or when strokes are to be adjusted by installing a stroke adjusting unit, the protective cover must be removed for these purposes.

- For detailed assembly step, refer to page 1082.

3. Do not apply a strong impact or moment on the slide table (slider).

- Since the slide table (slider) is supported by precision bearings, do not subject it to strong impact or excessive moment when mounting workpieces.

4. When connecting to a load which has an external guide mechanism, use a discrepancy absorption mechanism.

- A mechanically jointed rodless cylinder can be used with a direct load within the allowable range for each guide type, however, align carefully when connecting to a load with an external guide mechanism.

Mount the external guide mounting brackets and floating brackets in a place where the required degree of freedom for the floating Y and Z axes can be secured.

The thrust transmission area of the floating bracket must be fixed so that it does not partially contact the body.

*Refer to the Coordinates and Moment in Model Selection on page 1060 for the details of floating Y and Z axes.

5. Do not mount cylinders as they are twisted.

- When mounting, be sure for a cylinder tube not to be twisted. The flatness of the mounting surface is not appropriate, the cylinder tube is twisted, which may cause air leakage due to the detachment of a seal belt, damage a dust seal band, and cause malfunctions.

6. Do not mount a slide table on the fixed equipment surface.

- It may cause damage or malfunctions since an excessive load is applied to the bearing.

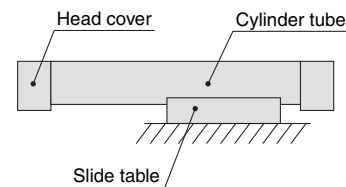

Mounting with a slide table (slider)

7. Consult SMC when mounting in a cantilevered way.

- Since the cylinder body deflects, it may cause malfunctions. Please consult with SMC when using it this way.

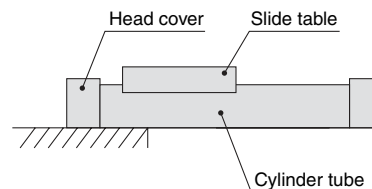

Mounting in a cantilevered way



Series MY1□W

Specific Product Precautions 2

Be sure to read before handling.

Refer to front matters 54 and 55 for Safety Instructions and pages 3 to 11 for Actuator and Auto Switch Precautions.

Handling

⚠ Caution

- Fixed parts of the cylinder on both ends must have at least 5 mm of contact between where the bottom of the cylinder tube and the equipment surface.

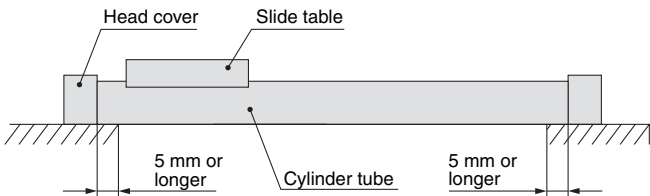

- Do not generate negative pressure in the cylinder tube.

- Take precautions under operating conditions in which negative pressure is generated inside the cylinder by external forces or inertial forces. Air leakage may occur due to separation of the seal belt. Do not generate negative pressure in the cylinder by forcibly moving it with an external force during the trial operation or dropping it with self-weight under the non-pressure state, etc. When the negative pressure is generated, slowly move the cylinder by hand and move the stroke back and forth. After doing so, if air leakage still occurs, please consult with SMC.

- Accuracy

- The mechanical jointed rodless cylinder does not guarantee traveling parallelism. When accuracy in traveling parallelism and a middle position of stroke is required, consult with SMC.

- Cautions on less frequent operation

- When the cylinder is used extremely infrequently, operation may be interrupted in order for anchoring and a change lubrication to be performed or service life may be reduced.

Handling

⚠ Caution

- Do not unnecessarily alter the guide adjustment setting.

- The adjustment of the guide is preset and does not require readjustment under normal operating conditions. Therefore, do not unnecessarily alter the guide adjustment setting. However, series other than the MY1□W series can be readjusted and their bearings can be replaced. To perform these operations, refer to the bearing replacement procedure given in the instruction manual.

- Avoid operation that causes negative pressure inside the cylinder.

- Take precautions under operating conditions in which negative pressure is increased inside the cylinder by external forces or inertial forces. Air leakage may occur due to separation of the seal belt.

- Do not get your hands caught during cylinder operation.

- For the cylinder with a stroke adjusting unit, the space between the slide table and stroke adjusting unit is very small, and your hands may get caught. When operating without a protective cover, be careful not to get your hands caught.

Operating Environment

⚠ Caution

- Because of floating particles such as paper dust and coolant mist that may enter the inside of the cover.

- Since there is a gap between the bottom of the cover and cylinder tube, take precautions when operating cylinders in environments where there is exposure to excessive amount of floating particles, water/oil splash, or chip spattering. If they enter inside the cover, malfunction may occur.

- Carry out cleaning and grease application suitable for the operating environment.

- Carry out cleaning regularly when using in an operating environment in which the product is likely to get dirty. After cleaning, be sure to apply grease to the top side of the cylinder tube and the rotating part of the dust seal band. Apply grease to these parts regularly even if not after cleaning. Please consult with SMC for the cleaning of the slide table (slider) interior and grease application.

Service Life and Replacement Period of Shock Absorber

⚠ Caution

- Allowable operating cycle under the specifications set in this catalog is shown below.

1.2 million times RB08□□

2 million times RB10□□ to RB2725

- Note) Specified service life (suitable replacement period) is the value at room temperature (20 to 25°C). The period may vary depending on the temperature and other conditions. In some cases the absorber may need to be replaced before the allowable operating cycle above.

MY1B

MY1M

MY1C

MY1H

MY1HT

MY1□W

MY2C

MY2H□

MY3A

MY3B

MY3M

D-□

-X□

Individual

-X□

Technical data



Series MY1□W

Specific Product Precautions 3

Be sure to read before handling.

Refer to front matters 54 and 55 for Safety Instructions and pages 3 to 11 for Actuator and Auto Switch Precautions.

Assembly Procedure

1 Component check

Check the components.

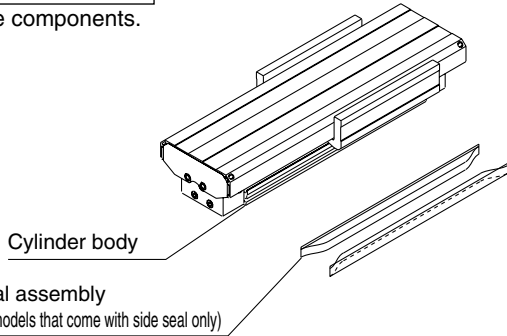

Note) When auto switches are included with a cylinder order, they are packaged together with the cylinder.

2 Body mounting procedures

1. Removal of cover

Remove the hexagon socket head button bolts and cover.

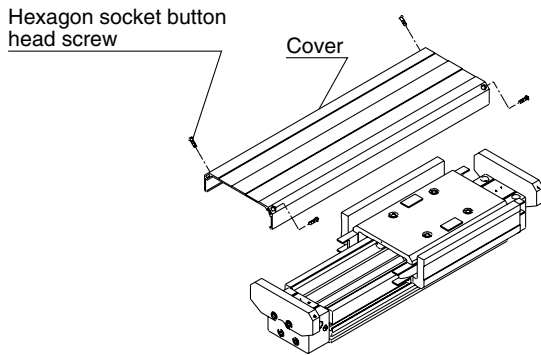

2. Body mounting/adjustment

Mount the cylinder body.

For cylinders with protective cover only (i.e., without side seal), reinstall the cover after the cylinder is mounted and adjusted. (Refer to Step ③-3 "Cover installation".)

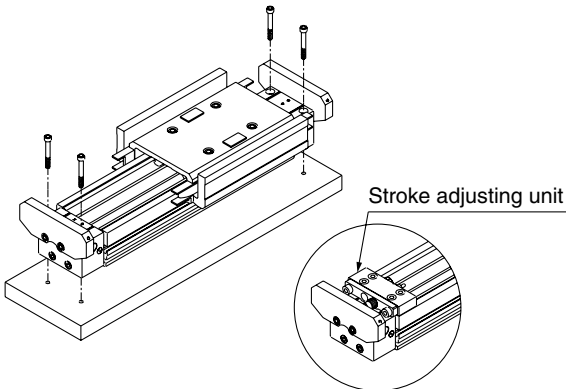

Note) The adjustment of the stroke adjusting unit (optional) should also be done at this time.

3 Side seal installation procedures

1. Temporary cover installation

- 1) Remove the hexagon socket head cap screws and one of the end plates.
- 2) Place the cover and temporarily secure it with the hexagon socket button head bolts.

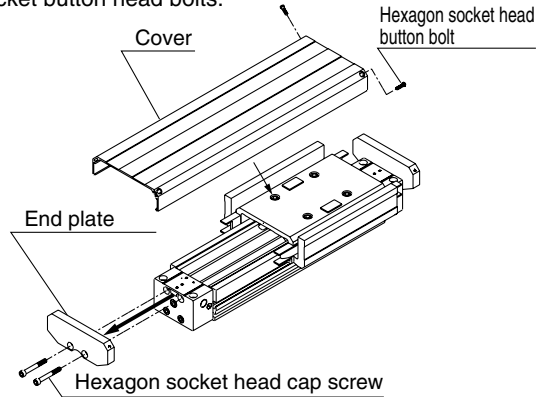

2. Side seal installation

Slide the side seal assembly into the place from one end of the cylinder.



Stainless steel portions of the side seal assembly are very sharp. Take extra precautions when handling.

Note) Move the slide table to the end of the insertion side.

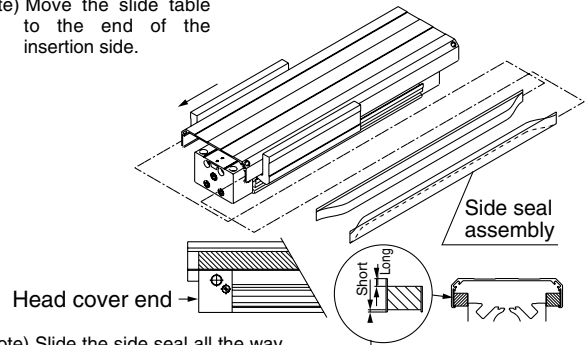

Note) Slide the side seal all the way to the end of the head cover.

Note) Make sure the side seal assembly is facing in the right direction.



Series MY1□W

Specific Product Precautions 4

Be sure to read before handling.

Refer to front matters 54 and 55 for Safety Instructions and pages 3 to 11 for Actuator and Auto Switch Precautions.

Assembly Procedure

4 Side seal installation procedures (Continued)

3. Cover installation

* Be sure to confirm Note 1) and Note 2). (When adjustment is not correctly done, it may cause malfunctions and parts damage (cover collision).)

- 1) The end plate is fixed with hexagon socket head cap screws.
- 2) The cover is fixed with hexagon socket button head screws.

Hexagon socket button head screw

Cover tightening torque [N·m]

Bore	Thread size	Torque
ø16 to ø40	M3	0.6
ø50, ø63	M4	1.4

End plate

Note 1) Do not move the end plate upward inadvertently.

Hexagon socket head cap screw

End plate tightening torque [N·m]

Bore	Thread size	Torque
ø16	M3	0.7
ø20	M4	1.8
ø25	M5	3.5
ø32	M6	5.8
ø40	M6	5.8
ø50	M8	14
ø63	M10	28

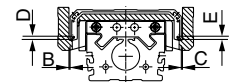

Note 2) If there is no gap (clearance) between the slide table and cover (B, C and D, E in the drawing above) throughout the stroke range, loosen the hexagon socket head cap screw to fix the end plate, then retighten it after adjusting the end plate position.

MY1B

MY1M

MY1C

MY1H

MY1HT

MY1□W

MY2C

MY2H□

MY3A

MY3B

MY3M

Centralized Piping Port Variations

Caution

- Head cover piping connection can be freely selected to best suit different piping conditions.

Applicable cylinder	Port variation
MY1MW16, 20, 50, 63 MY1CW16, 20, 50, 63	
MY1MW25, 32, 40 MY1CW25, 32, 40	

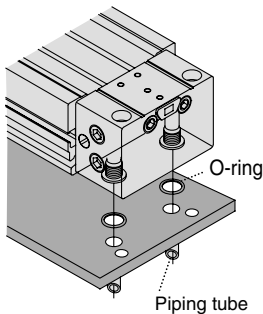

For bottom piping, refer to the figure above.

D-□

-X□

Individual

-X□

Technical

data

Made to Order Common Specifications: -XB11: Long Stroke Type



6 Long Stroke Type

Symbol
-XB11

Stroke which exceeds the standard stroke length

Applicable Series

Series	Description	Model	Type	Note	Vol. no. (for std model)
CX2	Slide unit	CX2	Slide bearing type		⑤ From P. 464
CXW	Slide unit	CXWM	Slide bearing type		⑤ From P. 473
		CXWL	Ball bushing bearing type		
CXS	Dual rod cylinder	CXS	Standard type		⑤ From P. 561
		CXSW	Double rod type		
CY3	Magnetically coupled rodless cylinder	CY3B	Basic type		② From P. 1174
MY1	Mechanically jointed rodless cylinder	MY1B	Basic type		② From P. 956
		MY1M(W)	Slide bearing type	With cover (W) is also available.	
		MY1C(W)	Cam follower guide type	With cover (W) is also available.	
		MY1H	Linear guide type	Except $\phi 10$	
MY2	Mechanically jointed rodless cylinder	MY2C	Cam follower guide type		② From P. 1098
		MY2H/HT	Linear guide type		
MY3	Mechanically jointed rodless cylinder	MY3A	Basic short type		② From P. 1121
		MY3B	Basic standard type		
		MY3M	Slide bearing type		
CQ2	Compact cylinder	CQ2AH	Air-hydro type	Except with rubber bumper	② From P. 602
ML1	Hy-rodless cylinder	ML1C	Cam follower guide type		⑤ From P. 912
REA	Sine rodless cylinder	REA	Basic type		⑤ From P. 935

How to Order

Standard model no. **-XB11**

Long stroke type

* Enter a symbol for stroke required.

Specifications: Same as standard type.

Stroke Range

Series	Bore size (mm)	Standard stroke (mm)	Long stroke (mm)
MY1B	10, 16, 20, 25, 32, 40, 50, 63, 80, 100	100 to 2000	2001 to 5000 (Up to 3000 for $\phi 10, \phi 16$)
MY1M(W)	16, 20, 25, 32, 40, 50, 63	100 to 2000	2001 to 5000 (3000 for $\phi 16$ only, 3000 for MY1MW)
MY1C(W)	16, 20, 25, 32, 40, 50, 63	100 to 2000	2001 to 5000 (3000 for $\phi 16$ only, 3000 for MY1CW)
MY1H	16, 20, 25, 32, 40	50 to 600	601 to 1500 (1000 for $\phi 16$ to $\phi 20$ only)
MY2C	16, 25, 40	100 to 2000	2001 to 5000 (Up to 3000 for $\phi 16$)
MY2H/HT	16, 25, 40	50 to 600	601 to 1500 (Up to 1000 for $\phi 16$)
MY3A MY3B MY3M	16, 25, 40, 63	100 to 2000	2001 to 3000
CXS	10	10 to 75	80, 90, 100, 110, 120, 125, 150
	15	10 to 100	110, 120, 125, 150
	20, 25, 32	10 to 100	110, 120, 125, 150, 175, 200
CXSW	10, 15	10, 20, 30, 40, 50	75, 100, 125, 150
	20, 25, 32	10, 20, 30, 40, 50, 75, 100	125, 150, 175, 200
CX2	15, 25	25 to 200	225, 250, 275, 300
CXWM	16, 20, 25, 32	25 to 200	225, 250, 275, 300 (CXWM16 to 25) 225, 250 (CXWM32)
			225, 250, 275 (CXWL16 to 25) 225 (CXWL32)
CXWL			
ML1	25, 32, 40	100 to 1000	1001 to 2000
CY3B	25, 32, 40, 50, 63	100 to 1000	2001 to 3000 ($\phi 25$ to $\phi 40$) 2001 to 5000 ($\phi 50, \phi 63$)
REA	25, 32, 40, 50, 63	200 to 1000	2001 to 4000 ($\phi 25, \phi 32$) 2001 to 5000 ($\phi 40$) 2001 to 6000 ($\phi 50, \phi 63$)
CQ2AH	32, 40, 50, 63, 80, 100	(5), 10, 15, 20, 25, 30, 35, 40, 45, 50, 75, 100	125, 150, 175, 200, 250, 300

-X□
Individual
-X□



Actuators Precautions 1

Be sure to read this before handling.

Design / Selection

Warning

1. Confirm the specifications.

Products represented in this catalog are designed only for use in compressed air systems (including vacuum).

Do not operate at pressures or temperatures, etc., beyond the range of specifications, as this can cause damage or malfunction. (Refer to the specifications.)

Please contact SMC when using a fluid other than compressed air made by pneumatic equipment (including vacuum).

We do not guarantee against any damage if the product is used outside of the specification range.

2. Confirm the applicable specification range.

The cylinder specifications listed in this catalog apply to standard strokes, including intermediate strokes. Please consult with SMC for specifications on long strokes. There are also some made-to-order products (-XB□/-XC□) for which product specifications do not apply.

3. There is a danger of sudden action by cylinders if sliding parts of machinery are twisted, etc., and changes in forces occur.

In such cases, human injury may occur; e.g., by catching hands or feet in the machinery, or damage to the machinery itself may occur. Therefore, the machine should be designed to operate smoothly and to avoid such dangers.

4. If there is a chance that the product will pose a hazard to humans, install a protective cover.

If the moving portion of the product will pose a hazard to humans or will damage machinery or equipment, provide a construction that prevents direct contact with those areas.

5. Be certain that the secured portions will not loosen.

Be certain to adopt a reliable connecting method if the cylinder is used very frequently or if it is used in a location that is exposed to a large amount of vibration.

6. There may be cases in which a speed reduction circuit or a shock absorber is required.

If the driven object moves at high speeds or is heavy, it will be unfeasible for only the cylinder's cushion to absorb the shock. Therefore, provide a speed-reduction circuit to reduce the cylinder's speed before the thrust is applied to the cushion, or an external shock absorber to dampen the shock. If these countermeasures are taken, make sure to take the rigidity of the mechanical equipment into consideration.

7. Consider the possibility of power source related malfunction that could occur.

For the equipment that rely on power sources such as compressed air, electricity, or hydraulic pressure, adopt a countermeasure to prevent the equipment from causing a hazard to humans or damage to the equipment in the event of malfunction.

8. Design the circuitry to prevent sudden lurching of driven objects.

When a cylinder is driven by an exhaust center type directional control valve or when starting up after residual pressure is exhausted from the circuit, etc., the piston and its driven object will lurch at high speed if pressure is applied to one side of the cylinder because of the absence of air pressure inside the cylinder. Therefore, select equipment and design circuits to prevent sudden lurching, because there is a danger of human injury and/or damage to equipment when this occurs.

9. Consider the behavior of the cylinder in the event of an emergency stop.

Devise a safe system so that if a person engages the emergency stop, or if a safety device is tripped during a system malfunction such as a power outage, the movement of the cylinder will not cause a hazard to humans or damage the equipment.

10. Avoid synchronized operation using cylinders only.

Even if multiple pneumatic cylinders are initially set to the same speed, their speed may vary due to changes in operating conditions. Therefore, avoid designs where a single load is moved by synchronizing multiple cylinder operations.

11. Consider the action of the cylinder when restarting after an emergency stop.

Devise a safe design so that the restarting of the cylinder will not pose a hazard to humans or damage the equipment. Install manually controlled equipment for safety when the actuator has to be reset to the starting position.

12. Intermediate stops

When intermediate stopped position is performed with a 3 position closed center type/double check valve type directional control valve, it is difficult to achieve accurate and precise stopped positions due to the compressibility of air.

Furthermore, since valves or cylinders are not guaranteed for zero air leakage, it may not be possible to hold a stopped position for an extended period of time. Please contact SMC in case it is necessary to hold a stopped position for an extended period.

13. Do not disassemble the product or make any modifications, including additional machining.

It may cause human injury and/or an accident.

14. Refer to the Auto Switches Precautions for using with an auto switch.

15. When a cylinder is used in a clamping, suspending and lifting mechanism

There is a danger of workpieces dropping if there is a decrease of thrust due to a drop in circuit pressure caused by a power outage, etc. Therefore, safety equipment should be installed to prevent damage to machinery and/or human injury.



Actuators Precautions 2

Be sure to read this before handling.

Design / Selection

⚠ Caution

1. Use the product within the limits of the maximum usable stroke.

The piston rod will be damaged if operated beyond the maximum stroke. Refer to the Cylinder Model Selection Procedure for the maximum useable stroke.

2. Operate the cylinder component parts within a range such that collision damage will not occur at the stroke end.

For applications where a piston with inertial force strikes a cover and stops at the stroke end, follow the cylinder model selection procedure (front matters 21 and 31), or select while taking into account the allowable kinetic energy indicated in the each model specifications.

3. Use a speed controller to adjust the cylinder drive speed, gradually increasing from a low speed to the desired speed setting.

4. Provide intermediate supports for long stroke cylinders.

Provide intermediate supports for cylinders with long strokes to prevent rod damage due to sagging of the rod, deflection of the tube, vibration and external loads, etc.

In addition, thoroughly examine the possibility of buckling and establish safety measures, such as constructing a guide outside of the product, etc.

5. If pressure is applied to the external cylinder parts, there is a possibility that air will get inside the cylinder from the rod seal section. (Example: inside a chamber, etc.)

Mounting

⚠ Warning

1. Operation manual

Install the product and operate it only after reading the operation manual carefully and understanding its contents. Also, keep the manual in a location where it can be referred to as necessary.

2. Ensure sufficient space for maintenance activities.

When installing the products, allow access for maintenance.

3. Tighten threads with the proper tightening torque.

When installing the products, follow the listed torque specifications.

4. Do not place a magnetic object near the product.

The auto switch is a magnetic sensing type. If a magnetic object is placed close to it, the rotary actuator could operate suddenly, which could pose a hazard to humans and damage the machinery and equipment.

5. Do not perform additional machining to the product.

Additional machining to the product can result in insufficient strength and cause damage to the product. This can lead to possible human injury and damage to the surrounding equipment.

6. Do not enlarge the fixed throttle by modifying the pipe connectors.

If the hole diameter is enlarged, the product's rotation speed will increase, causing the shock force to increase and damage to the product. As a result, it could pose a hazard to humans and damage the machinery and equipment.

Mounting

⚠ Caution

1. Be certain to align the rod axis with the load and direction of movement when connecting.

When not properly aligned, the rod and tube may be twisted, and damage may be caused due to wear on areas such as the inner tube surface, bushings, rod surface and seals.

2. When an external guide is used, connect the rod end and the load in such a way that there is no interference at any point within the stroke.

3. Do not scratch or gouge the sliding parts of the cylinder tube or piston rod, etc., by striking or grasping them with other objects.

Cylinder bores are manufactured to precise tolerances, so that even a slight deformation may cause malfunction. Also, scratches or gouges, etc., in the piston rod may lead to damaged seals and cause air leakage.

4. Prevent the seizure of rotating parts.

Prevent the seizure of rotating parts (pins, etc.) by applying grease.

5. Do not use until you can verify that equipment can operate properly.

Verify correct mounting by function and leak tests properly after compressed air and power are connected following mounting or repair.

6. Cantilever fastening

If a cylinder is actuated at high speed when mounted with one side fastened and one side free (basic type, flange type, direct mount type), the bending moment may act on the cylinder due to vibration at the stroke end, causing damage to the cylinder. In such cases, install a mounting bracket to suppress vibration of the cylinder body, or reduce piston speed until the cylinder body does not vibrate at the stroke end.

Also, use a mounting bracket when moving the cylinder body, or mounting a long stroke cylinder horizontally with one-sided fastening.

7. Be very careful when handling the product.

Depending on the handling method, there is a risk that the corners of the product will injure your hand or fingers, etc.

8. Mount an auto switch at the center of the operating range.

Adjust the mounting position of an auto switch so that the piston stops at the center of the operating range (the range in which a switch is ON). (The mounting position shown in the catalog indicates the optimum position at stroke end.) If mounted at the end of the operating range (around the borderline of ON and OFF), operation will be unstable or the service life for reed switches may be reduced.



Actuators Precautions 3

Be sure to read this before handling.

Piping

⚠ Caution

1. Refer to the Fittings and Tubing Precautions (Best Pneumatics No. 6) for handling one-touch fittings.
2. Preparation before piping
Before piping is connected, it should be thoroughly blown out with air (flushing) or washed to remove chips, cutting oil and other debris from inside the pipe.
3. Wrapping of pipe tape
When screwing piping or fittings into ports, ensure that chips from the pipe threads or sealing material do not enter the piping. Also, if pipe tape is used, leave 1.5 to 2 thread ridges exposed at the end of the threads.

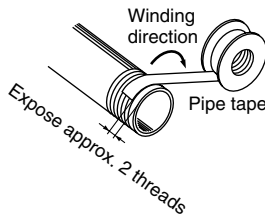

Cushion

⚠ Caution

1. Readjust using the cushion needle.
Adjust the cushion needle on the cover when the product is put into service, based upon factors such as the size of the load and the operating speed. When the cushion needle is turned clockwise, the restriction becomes smaller and the cushion's effectiveness is increased. Tighten the lock nut securely after adjustment is performed.
2. Do not operate with the cushion needle in a fully closed condition.
This could tear the seal.

Lubrication

⚠ Warning

1. Lubricating the lube type cylinder
Install a lubricator in the circuit, and use class 1 turbine oil (with no additive) ISO VG32. Do not use machine oil or spindle oil. If turbine oil is used, refer to the Material Safety Data Sheet (MSDS) of the oil.
2. Lubricating the non-lube type cylinder
The cylinder has been lubricated for life at the factory and can be used without any further lubrication. However, in the event that it is additionally lubricated, be sure to use class 1 turbine oil (with no additive) ISO VG32. Do not use machine oil or spindle oil. Stopping lubrication later may lead to malfunction because the new lubricant will displace the original lubricant. Therefore, lubrication must be continued once it has been started. If turbine oil is used, refer to the corresponding Material Safety Data Sheet (MSDS).

Air Supply

⚠ Warning

1. Type of fluids
Please consult with SMC when using the product in applications other than compressed air.
2. When there is a large amount of drainage.
Compressed air containing a large amount of drainage can cause malfunction of pneumatic equipment. An air dryer or water separator should be installed upstream from filters.
3. Drain flushing
If condensation in the drain bowl is not emptied on a regular basis, the bowl will overflow and allow the condensation to enter the compressed air lines. It causes malfunction of pneumatic equipment. If the drain bowl is difficult to check and remove, installation of a drain bowl with an auto drain option is recommended. For compressed air quality, refer to Best Pneumatics No. 5.
4. Use clean air.
Do not use compressed air that contains chemicals, synthetic oils including organic solvents, salt or corrosive gases, etc., as it can cause damage or malfunction.

⚠ Caution

1. When extremely dry air is used as the fluid, degradation of the lubrication properties inside the equipment may occur, resulting in reduced reliability (or reduced service life) of the equipment. Please contact SMC.
2. Install an air filter.
Install an air filter upstream near the valve. Select an air filter with a filtration size of 5 µm or smaller.
3. Take measures to ensure air quality, such as by installing an aftercooler, air dryer, or water separator.
Compressed air that contains a large amount of drainage can cause malfunction of pneumatic equipment such as valves. Therefore, take appropriate measures to ensure air quality, such as by providing an aftercooler, air dryer, or water separator.
4. Ensure that the fluid and ambient temperature are within the specified range.
If the fluid temperature is 5°C or less, the moisture in the circuit could freeze, causing damage to the seals and equipment malfunction. Therefore, take appropriate measures to prevent freezing. For compressed air quality, refer to Best Pneumatics No. 5.



Actuators Precautions 4

Be sure to read this before handling.

Operating Environment

Warning

1. **Do not use in an atmosphere having corrosive gases, chemicals, sea water, water, water steam, or where there is direct contact with any of these.**

Long machined parts made by machining plated carbon steel (end threads of piston rods, double-sided chamfer portion, tie rod threads etc.) are not plated. Consider a made-to-order product (-XC6/-XC7) when using in an environment where rusting or corrosion will be a problem. Refer to each construction on drawing on the rotary actuators material.

2. **Do not expose the product to direct sunlight for an extended period of time.**
3. **Do not use in a place subject to heavy vibration and/or shock.**
4. **Do not mount the product in locations where it is exposed to radiant heat.**
5. **Do not use in dusty locations or where water or oil, etc., splash on the equipment.**

Use the heavy duty scraper type (-XC4) in situations where there is a lot of dust. Use a water resistant cylinder when there is splashing or spraying of a liquid.
6. **When using auto switches, do not operate in an environment with strong magnetic fields.**
7. **If a shock absorber is attached to an actuator, read the Specific Product Precautions for the shock absorber.**
8. **A decrease in grease base oil may be accelerated by the properties of compressed air used in pneumatic equipment, the external environment, or operating conditions, etc., and the resulting drop in lubricating performance may have an effect on equipment service life.**

Caution

1. **Internal lubricant and grease base oil may seep out of the cylinder depending on operating conditions. Please consult with SMC in cases where a particularly clean environment is required.**

Maintenance

Warning

1. **Perform maintenance inspection according to the procedures indicated in the operation manual.**

If handled improperly, malfunction and damage of machinery or equipment may occur.

2. **Maintenance work**

If handled improperly, compressed air can be dangerous. Assembly, handling, repair and element replacement of pneumatic systems should be performed by a knowledgeable and experienced person.

3. **Drain flushing**

Remove drainage from air filters regularly.

4. **Removal of equipment, and supply/exhaust of compressed air**

When components are removed, first confirm that measures are in place to prevent workpieces from dropping, run-away equipment, etc. Then, cut off the supply pressure and electric power, and exhaust all compressed air from the system using the residual pressure release function.

When machinery is restarted, proceed with caution after confirming that appropriate measures are in place to prevent cylinders from sudden movement.



Auto Switches Precautions 1

Be sure to read this before handling.

Design / Selection

Warning

1. Confirm the specifications.

Read the specifications carefully and use this product appropriately. The product may be damaged or malfunction if it is used outside the specification range for current load, voltage, temperature or impact.

We do not guarantee against any damage if the product is used outside of the specification range.

2. Cautions for use in an interlock circuit

When an auto switch is used for an interlock signal requiring high reliability, devise a double interlock system to avoid trouble by providing a mechanical protection function, or by also using another switch (sensor) together with the auto switch. Also, perform periodic maintenance and confirm proper operation.

3. Do not make any modifications (including exchanging the printed circuit boards) to the product.

It may cause human injuries and accidents.

Caution

1. Pay attention to the length of time that a switch is ON at an intermediate stroke position.

When an auto switch is placed at an intermediate position of the stroke and a load is driven at the time the piston passes, the auto switch will operate, but if the speed is too great the operating time will be shortened and the load may not operate properly. The maximum detectable piston speed is:

$$V \text{ (mm/s)} = \frac{\text{Auto switch operating range (mm)}}{\text{Time load applied (ms)}} \times 1000$$

In cases of high piston speed, the use of an auto switch (D-F5NNTL, F7NNTL, G5NNTL, M5NNTL, M5PNTL) with a built-in OFF delay timer (≈ 200 ms) makes it possible to extend the load operating time.

The wide-range detection type D-G5NBL (operating range 35 to 50 mm) may also be useful, depending on the application. Please consult with SMC for other models.

Caution

2. Keep wiring as short as possible.

<Reed>

As the length of the wiring to a load gets longer, the rush current at switching ON becomes greater, and this may shorten the product's life. (The switch will stay ON all the time.)

1) Use a contact protection box when the wire length is 5 m or longer.

2) Even if an auto switch has a built-in contact protection circuit, when the wiring is more than 30 m long, it is not able to adequately absorb the rush current and its life may be reduced. It is again necessary to connect a contact protection box in order to extend its life. Please consult with SMC in this case.

<Solid state>

3) Although wire length should not affect switch function, use a wire 100 m or shorter.

If the wiring is longer it will likely increase noise although the length is less than 100 m.

When the wire length is long, we recommend the ferrite core is attached to the both ends of the cable to prevent excess noise.

A contact protection box is not necessary for solid state switches due to the nature of this product construction.

3. Do not use a load that generates surge voltage. If a surge voltage is generated, the discharge occurs at the contact, possibly resulting in the shortening of product life.

If driving a load such as a relay that generates a surge voltage,

<Reed>

Use an auto switch with built-in contact protection circuit or use a contact protection box.

<Solid state>

Use a built-in surge absorbing element type device.

4. Take precautions when multiple cylinders/actuators are used close together.

When multiple auto switch cylinders/actuators are used in close proximity, magnetic field interference may cause the auto switches to malfunction. Maintain a minimum cylinder separation of 40 mm. (When the allowable interval is specified for each cylinder series, use the indicated value.)

The auto switches may malfunction due to the interference from the magnetic fields.

Use of a magnetic screen plate (MU-S025) or commercially available magnetic screen tape can reduce the interference of magnetic force.



Auto Switches Precautions 2

Be sure to read this before handling.

Design / Selection

⚠ Caution

5. Pay attention to the internal voltage drop of the auto switch.

<Reed>

1) Auto switch with an indicator light (Except D-A56, A76H, A96, A96V, C76, E76A, Z76)

- If auto switches are connected in series as shown below, take note that there will be a large voltage drop because of internal resistance in the light emitting diodes. (Refer to the internal voltage drop in the auto switch specifications.) [The voltage drop will be “n” times larger when “n” auto switches are connected.]

Even though an auto switch operates normally, the load may not operate.

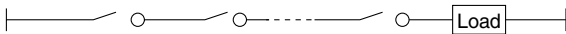

- In the same way, when operating under a specified voltage, although an auto switch may operate normally, the load may not operate. Therefore, the formula below should be satisfied after confirming the minimum operating voltage of the load.

$$\text{Supply voltage} - \text{Internal voltage drop of auto switch} > \text{Minimum operating voltage of load}$$

2) If the internal resistance of a light emitting diode causes a problem, select an auto switch without an indicator light (D-A6□, A80, A80H, A90, A90V, C80, R80, 90, E80A, Z80).

<Solid state/2-wire type>

3) Generally, the internal voltage drop will be greater with a 2-wire solid state auto switch than with a reed auto switch. Take the same precautions as in 1). Also, take note that a 12 VDC relay is not applicable.

6. Pay attention to leakage current.

<Solid state/2-wire type>

Current (leakage current) flows to the load to operate the internal circuit even when in the OFF state.

Operating current of load (OFF condition) > Leakage current

If the criteria given in the above formula are not met, it will not reset correctly (stays ON). Use a 3-wire switch if this specification will not be satisfied.

Moreover, leakage current flow to the load will be “n” times larger when “n” auto switches are connected in parallel.

7. Ensure sufficient clearance for maintenance activities.

When designing an application, be certain to allow sufficient clearance for maintenance.

8. When multiple auto switches are required.

“n” indicates the number of auto switches which can be physically mounted on the cylinders/actuators. Detection intervals depends on the auto switch mounting structure and set position, therefore some required interval and set positions may not be available.

9. Limitations of detectable positioning

When using certain mounting brackets, the surface and position where an auto switch can be mounted maybe restricted due to physical interference. For example, when using some bracket types the auto switch cannot be surface mounted at the bottom side of foot bracket, etc.

Select the set position of the auto switch so that it does not interfere with the mounting bracket of the cylinders/actuators (such as trunnion or reinforcement ring).

10. Use the cylinder and auto switch in proper combination.

The auto switch is pre-adjusted to activate properly for an auto-switch-capable SMC cylinder/actuator.

If the auto switch is mounted improperly, used for another brand of cylinders/actuators or used after the alternation of the machine installation, the auto switch may not activate properly.

Mounting / Adjustment

⚠ Caution

1. Do not drop or bump.

Do not drop, bump or apply excessive impacts (300 m/s² or more for reed auto switches and 1000 m/s² or more for solid state auto switches) while handling. Although the body of the auto switch may not be damaged, the inside of the auto switch could be damaged and cause malfunction.

2. Observe the proper tightening torque for mounting an auto switch.

When an auto switch is tightened beyond the range of tightening torque, auto switch mounting screws, auto switch mounting brackets or auto switch may be damaged.

On the other hand, tightening below the range of tightening torque may allow the auto switch to slip out of position.

3. Do not carry a cylinder by the auto switch lead wires.

Never carry a cylinder by its lead wires. This may not only cause broken lead wires, but it may cause internal elements of the auto switch to be damaged by the stress.

4. Fix the auto switch with appropriate screw installed on the switch body. If using other screws, auto switch may be damaged.



Auto Switches Precautions 3

Be sure to read this before handling.

Wiring

⚠ Caution

1. Confirm proper insulation of wiring.

Be certain that there is no faulty wiring insulation (contact with other circuits, ground fault, improper insulation between terminals, etc.). Damage may occur due to excess current flow into a switch.

2. Do not wire with power lines or high voltage lines.

Wire separately from power lines or high voltage lines, avoiding parallel wiring or wiring in the same conduit with these lines. Control circuits containing auto switches may malfunction due to noise from these other lines.

3. Avoid repeatedly bending or stretching lead wires.

Broken lead wires will result from repeatedly applying bending stress or stretching force to the lead wires.

Stress and tensile force applied to the connection between the cable and auto switch increases the possibility of disconnection.

Fix the cable in the middle so that it is not movable in the area where it connects with the auto switch.

4. Be certain to connect the load before power is applied.

<2-wire type>

If the power is turned ON when an auto switch is not connected to a load, the auto switch will be instantly damaged because of excess current (short circuit).

It is the same as when the 2-wire brown lead wire (+, output) is directly connected to the (+) power supply terminal.

5. Do not allow short-circuit of loads.

<Reed>

If the power is turned ON with a load in a short circuited condition, the auto switch will be instantly damaged because of excess current flow into the switch.

<Solid state>

All models of D-J51, G5NB and PNP output type auto switches do not have built-in short circuit protection circuits.

If a load is short circuited, the auto switch will be instantly damaged as in the case of reed auto switches.

Take special care to avoid reverse wiring with the brown power supply line and the black output line on 3-wire type auto switches.

6. Avoid incorrect wiring.

<Reed>

A 24 VDC auto switch with indicator light has polarity. The brown lead wire or terminal No. 1 is (+), and the blue lead wire or terminal No. 2 is (-).

[For D-97, (+) is on the no-displayed side, (-) is on the black line side.]

1) If connections are reversed, an auto switch will operate, however, the light emitting diode will not light up.

Also, take note that a current greater than that specified will damage a light emitting diode and it will no longer operate.

Applicable model:

D-A73, A73H, A73C, C73, C73C, E73A, Z73

D-R73, R73C, 97, 93A, A93, A93V

D-A33, A34, A33A, A34A, A44, A44A

D-A53, A54, B53, B54

2) When using a 2-color indicator type auto switch (D-A79W, A59W and B59W), the auto switch will constantly remain ON if the connections are reversed.

<Solid state>

1) If connections are reversed on a 2-wire type auto switch, the auto switch will not be damaged if protected by a protection circuit, but the auto switch will always stay in an ON state. However, it is still necessary to avoid reversed connections, since the auto switch could be damaged by a load short circuit in this condition.

2) If connections are reversed (power supply line + and power supply line -) on a 3-wire type auto switch, the auto switch will be protected by a protection circuit. However, if the power supply line (+) is connected to the blue wire and the power supply line (-) is connected to the black wire, the auto switch will be damaged.

7. When the cable sheath is stripped, confirm the stripping direction. The insulator may be split or damaged depending on the direction. (D-M9□ only)

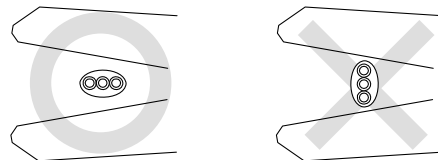

Recommended Tool

Description	Model
Wire stripper	D-M9N-SWY

* Stripper for a round cable (ø2.0) can be used for a 2-wire type cable.

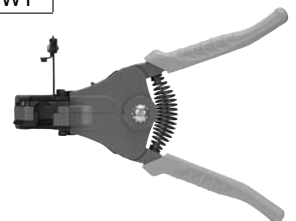



Auto Switches Precautions 4

Be sure to read this before handling.

Operating Environment

⚠ Warning

1. Never use in an atmosphere of explosive gases.

The structure of auto switches is not intended to prevent explosion. Never use in an atmosphere with an explosive gas since this may cause a serious explosion.

Please contact SMC concerning ATEX compliant products.

⚠ Caution

1. Do not use in an area where a magnetic field is generated.

Auto switches will malfunction or magnets inside cylinders/actuators will become demagnetized. (Please consult with SMC if a magnetic field resistant auto switch can be used.)

2. Do not use in an environment where the auto switch will be continually exposed to water.

Although auto switches satisfy IEC standard IP67 construction (JIS C 0920: waterproof construction) except some models (D-A3□, A44□, G39□, K39□, RNK, RPK) do not use auto switches in applications where continually exposed to water splash or spray. Poor insulation or swelling of the potting resin inside auto switches may cause malfunction.

3. Do not use in an environment with oil or chemicals.

Please consult with SMC if auto switches will be used in an environment with coolant, cleaning solvent, various oils or chemicals. If auto switches are used under these conditions for even a short time, they may be adversely affected by improper insulation, malfunction due to swelling of the potting resin, or hardening of the lead wires.

4. Do not use in an environment with temperature cycles.

Please consult with SMC if auto switches are used where there are temperature cycles other than normal temperature changes, as there may be adverse effects inside the auto switches.

5. Do not use in an environment where there is excessive impact shock.

<Reed>

When excessive impact (300 m/s² or more) is applied to a reed auto switch during operation, the contact point will malfunction and generate or cut off a signal momentarily (1 ms or less). Please consult with SMC if a solid state auto switch can be used according to the environment.

6. Do not use in an area where surges are generated.

<Solid state>

When there are units (solenoid type lifter, high frequency induction furnace, motor, radio equipment etc.) which generate a large amount of surge in the area around cylinders/actuators with solid state auto switches, this may cause deterioration or damage to the auto switch's internal circuit elements. Avoid sources of surge generation and disorganized lines.

⚠ Caution

7. Avoid accumulation of iron waste or close contact with magnetic substances.

When a large amount of iron waste such as machining chips or spatter is accumulated, or a magnetic substance (something attracted by a magnet) is brought into close proximity with a cylinder with auto switches, or an actuator, it may cause the auto switch to malfunction due to a loss of the magnetic force inside the cylinder/actuator.

8. Please contact SMC concerning water resistance, elasticity of lead wires, usage at welding sites, etc.

9. Do not use in direct sunlight.

10. Do not mount the product in locations where it is exposed to radiant heat.

Maintenance

⚠ Warning

1. Removal of equipment, and supply/exhaust of compressed air

Before any machinery or equipment is removed, first ensure that the appropriate measures are in place to prevent the fall or erratic movement of driven objects and equipment, then cut off the electric power and reduce the pressure in the system to zero. Only then should you proceed with the removal of any machinery and equipment.

When machinery is restarted, proceed with caution after confirming that appropriate measures are in place to prevent actuators from moving suddenly.

⚠ Caution

1. Perform the following maintenance periodically in order to prevent possible danger due to unexpected auto switch malfunction.

1) Secure and tighten auto switch mounting screws.

If screws become loose or the mounting position is dislocated, retighten them after readjusting the mounting position.

2) Confirm that there is no damage to lead wires.

To prevent faulty insulation, replace auto switches or repair lead wires, etc., if damage is discovered.

3) Confirm the lighting of the green light on the 2-color indicator type auto switch.

Confirm that the green LED is on when stopped at the established position. If the red LED is on, the mounting position is not appropriate. Readjust the mounting position until the green LED lights up.





Safety Instructions

These safety instructions are intended to prevent hazardous situations and/or equipment damage. These instructions indicate the level of potential hazard with the labels of “**Caution**,” “**Warning**” or “**Danger**.” They are all important notes for safety and must be followed in addition to International Standards (ISO/IEC), Japan Industrial Standards (JIS)*1) and other safety regulations*2).

- * 1) ISO 4414: Pneumatic fluid power – General rules relating to systems.
- ISO 4413: Hydraulic fluid power – General rules relating to systems.
- IEC 60204-1: Safety of machinery – Electrical equipment of machines. (Part 1: General requirements)
- ISO 10218-1992: Manipulating industrial robots -Safety.
- JIS B 8370: General rules for pneumatic equipment.
- JIS B 8361: General rules for hydraulic equipment.
- JIS B 9960-1: Safety of machinery – Electrical equipment of machines. (Part 1: General requirements)
- JIS B 8433-1993: Manipulating industrial robots - Safety.
- etc.
- * 2) Labor Safety and Sanitation Law, etc.

 **Caution:** Operator error could result in injury or equipment damage.

 **Warning:** Operator error could result in serious injury or loss of life.

 **Danger :** In extreme conditions, there is a possibility of serious injury or loss of life.

Warning

1. The compatibility of the product is the responsibility of the person who designs the equipment or decides its specifications.

Since the product specified here is used under various operating conditions, its compatibility with specific equipment must be decided by the person who designs the equipment or decides its specifications based on necessary analysis and test results. The expected performance and safety assurance of the equipment will be the responsibility of the person who has determined its compatibility with the product. This person should also continuously review all specifications of the product referring to its latest catalog information, with a view to giving due consideration to any possibility of equipment failure when configuring the equipment.

2. Only personnel with appropriate training should operate machinery and equipment.

The product specified here may become unsafe if handled incorrectly. The assembly, operation and maintenance of machines or equipment including our products must be performed by an operator who is appropriately trained and experienced.

3. Do not service or attempt to remove product and machinery/equipment until safety is confirmed.

1. The inspection and maintenance of machinery/equipment should only be performed after measures to prevent falling or runaway of the driven objects have been confirmed.

2. When the product is to be removed, confirm that the safety measures as mentioned above are implemented and the power from any appropriate source is cut, and read and understand the specific product precautions of all relevant products carefully.

3. Before machinery/equipment is restarted, take measures to prevent unexpected operation and malfunction.

4. Contact SMC beforehand and take special consideration of safety measures if the product is to be used in any of the following conditions.

1. Conditions and environments outside of the given specifications, or use outdoors or in a place exposed to direct sunlight.

2. Installation on equipment in conjunction with atomic energy, railways, air navigation, space, shipping, vehicles, military, medical treatment, combustion and recreation, or equipment in contact with food and beverages, emergency stop circuits, clutch and brake circuits in press applications, safety equipment or other applications unsuitable for the standard specifications described in the product catalog.

3. An application which could have negative effects on people, property, or animals requiring special safety analysis.

4. Use in an interlock circuit, which requires the provision of double interlock for possible failure by using a mechanical protective function, and periodical checks to confirm proper operation.



Safety Instructions

Caution

The product is provided for use in manufacturing industries.

The product herein described is basically provided for peaceful use in manufacturing industries.

If considering using the product in other industries, consult SMC beforehand and exchange specifications or a contract if necessary. If anything is unclear, contact your nearest sales branch.

Limited Warranty and Disclaimer/Compliance Requirements

The product used is subject to the following “Limited Warranty and Disclaimer” and “Compliance Requirements”. Read and accept them before using the product.

Limited Warranty and Disclaimer

1. The warranty period of the product is 1 year in service or 1.5 years after the product is delivered.*3)

Also, the product may have specified durability, running distance or replacement parts. Please consult your nearest sales branch.

2. For any failure or damage reported within the warranty period which is clearly our responsibility, a replacement product or necessary parts will be provided.

This limited warranty applies only to our product independently, and not to any other damage incurred due to the failure of the product.

3. Prior to using SMC products, please read and understand the warranty terms and disclaimers noted in the specified catalog for the particular products.

* 3) Vacuum pads are excluded from this 1 year warranty.

A vacuum pad is a consumable part, so it is warranted for a year after it is delivered.

Also, even within the warranty period, the wear of a product due to the use of the vacuum pad or failure due to the deterioration of rubber material are not covered by the limited warranty.

Compliance Requirements

When the product is exported, strictly follow the laws required by the Ministry of Economy, Trade and Industry (Foreign Exchange and Foreign Trade Control Law).